

munro

TROUBLESHOOTING COMMON ISSUES CENTRIFUGAL PUMPS AND CONTROLS



FOR IRRIGATION

Troubleshooting Common Issues - Centrifugal Pumps and Controls

This guide was developed to assist you in troubleshooting common centrifugal pump issues for small turf and irrigation applications (5hp and below). If you need additional assistance, please contact Munro at 1.800.942.4270 or contact your local irrigation wholesaler.

Common Issues

“My pump is running, but the sprinklers are not acting normal.” See Reduced Performance (pg. 4)

“The pump is running, but there is no water coming out.” See Pump Runs But No Water (pg. 5)

“The water comes out, then goes away. Then it comes out...” See Pump Surging/Flow Cycles (pg. 6)

“The motor just sits there and hums.” See Motor Hums (pg. 7)

“When I turn the pump on, nothing happens.” See Motor Does Not Run At All (pg. 8)

“The pump runs for a little while and then stops and then starts again.” See Motor Cycles and/or Nothing Happens (pg. 9)

“Nothing is happening. I have a pump start relay.” See StartBox (pg.10)

“My pump runs for 30 seconds and shuts off and does not restart.” See SmartBox (pg. 11)

Evaluating the System

- | | |
|---|--|
| <ol style="list-style-type: none">1. Have there been any changes to the system environment?<ol style="list-style-type: none">a. New fencing – Possible damage to pipeworkb. Added zones – Pump is now undersizedc. Aeration or animals – Possible damage to sprinkler heads or pipeworkd. Water source – Lower levels than usual2. Look for obvious problem areas<ol style="list-style-type: none">a. Leaking from case or seal areab. Cracked or worn componentsc. Clogged filters or screensd. Damaged gaskets in camlocks and o-rings | <ol style="list-style-type: none">3. Determine the primary issue<ol style="list-style-type: none">a. Reduced Performance (pg. 4)b. Pump Runs but No Water (pg. 5)c. Pump Surging/Flow Cycles (pg. 6)d. Motor Hums (pg. 7)e. Motor Does Not Run (pg. 8)f. Motor Cycles (pg. 9)g. Munro StartBox (pg. 10)h. Munro SmartBox (pg. 11) |
|---|--|

Safety Precautions

- Remember when using any tool, refer to the manufacturer’s guidelines for proper use.
- ALWAYS turn the breaker off to work on a pump. Some troubleshooting checks require the pump to be energized, be sure the area is secure prior to the task. Be sure to turn the breaker off again if problem persists.
- NEVER examine, make wiring changes, or touch the motor before disconnecting the electrical supply. Thermal overload protectors automatically reset and can close the electrical circuit without warning.

How To

Check Volts Entering Pump

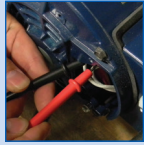

While the motor is running, use a voltmeter to determine if line voltage getting to the motor is the same as indicated leaving the breaker box.

Check for Air Leaks Using Plastic Wrap



Wrap plastic wrap tightly around a potential air leak path (union joint or cam fitting), turn pump on. If an air leak exists, the plastic wrap will tighten to the area.

Clear Centrifugal Switch



Debris can get caught in the centrifugal switch inside the motor. A soft hammer or 2x4 board can be used to firmly tap the butt of the motor. After three or four taps, try to engage the motor. If necessary, repeat.

Access the Wrench Slot



Check the motor shaft for a slot to fit an open-ended wrench. This can aid in diagnosis and tear-down/assembly procedure.

Tear Down and Reassembly of a Pump, Including to Replace a Seal or Clean the Impeller

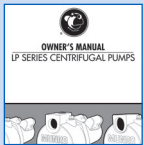

Refer to the Owners Manual for instructions on tearing down the pump to replace the seal, clean the impeller, or access the inside of the pump for any reason. Visit our YouTube channel for instructional videos: www.youtube.com/users/munrocompanies

Tools You May Need

- Soft faced hammer or 2x4 board
- Thin profile wrench – 9/16 and 5/8
- Wrench or socket set
- Voltmeter
- Pry bar
- Flathead screwdriver
- Plastic wrap
- Lubricant
- Pipe wrench

Possible Replacement Parts

- Gasket: case, diffuser, cam fitting
- Mechanical shaft seal
- Union o-rings



Did You Know?

A pressure gauge on the pump is a good indicator of system performance. Low pressure while the pump is running indicates a suction or obstruction problem. Normal pressure readings at the pump commonly indicate a sprinkler head or pipework problem.



Did You Know?

80% of all pump issues are on the suction side.

Troubleshooting Guide - Reduced Performance



Did You Know?

You cannot always find a suction leak by pressurizing a line. Air can seal under pressure but will enter pipe in a vacuum.

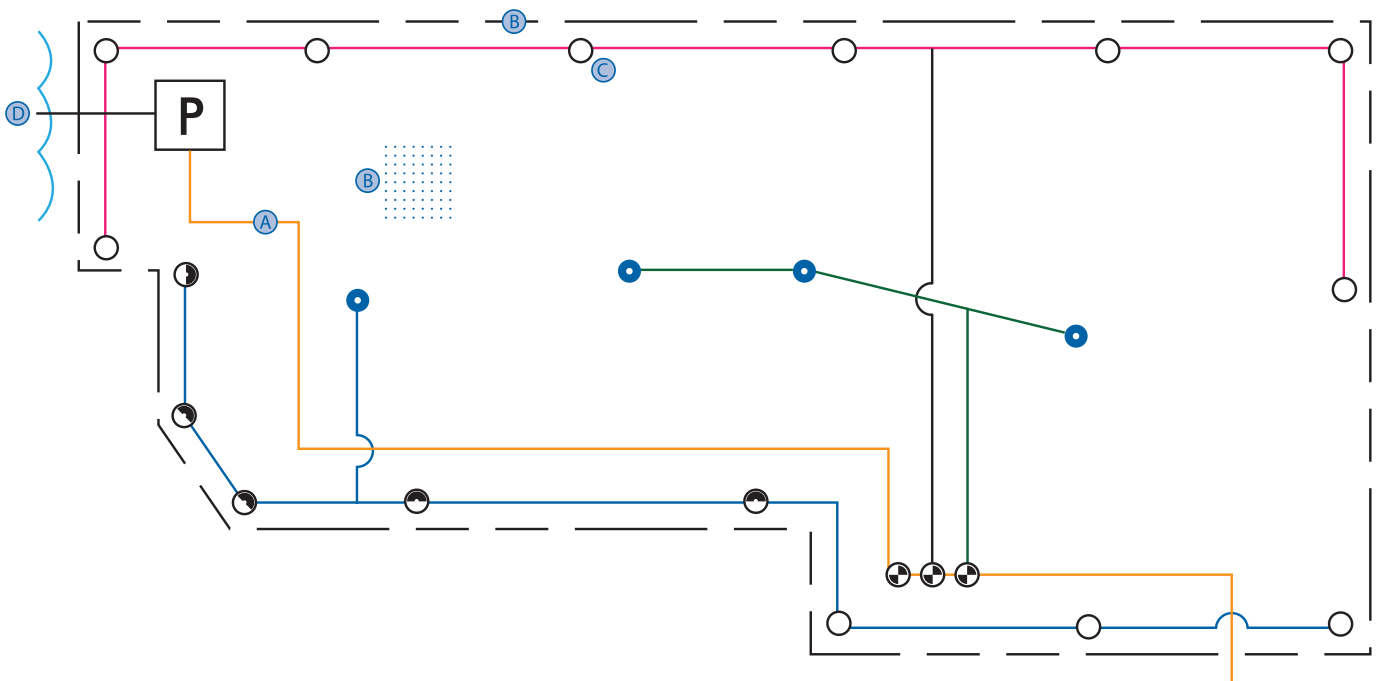
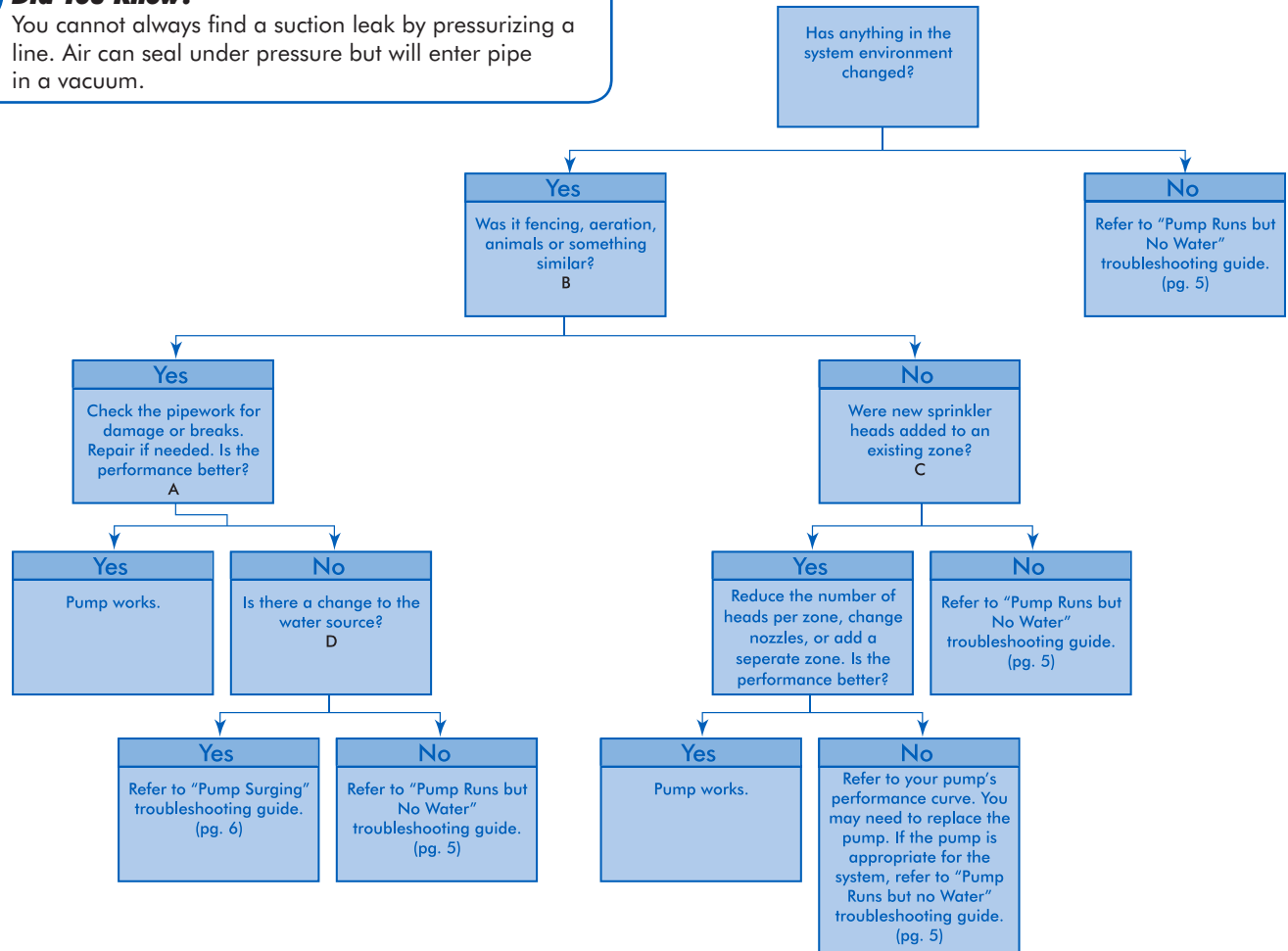

Troubleshooting Guide - Pump Runs but No Water



Did You Know?

Cam fittings are best used with the handles to the top and bottom. It reduces the chance of leaking from the weight of the hose.

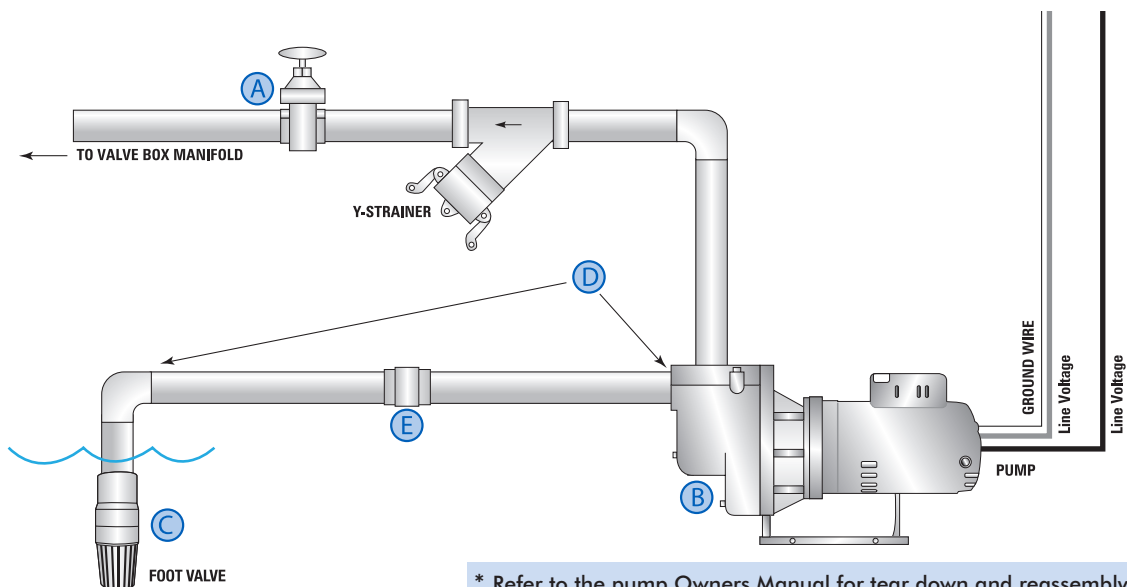
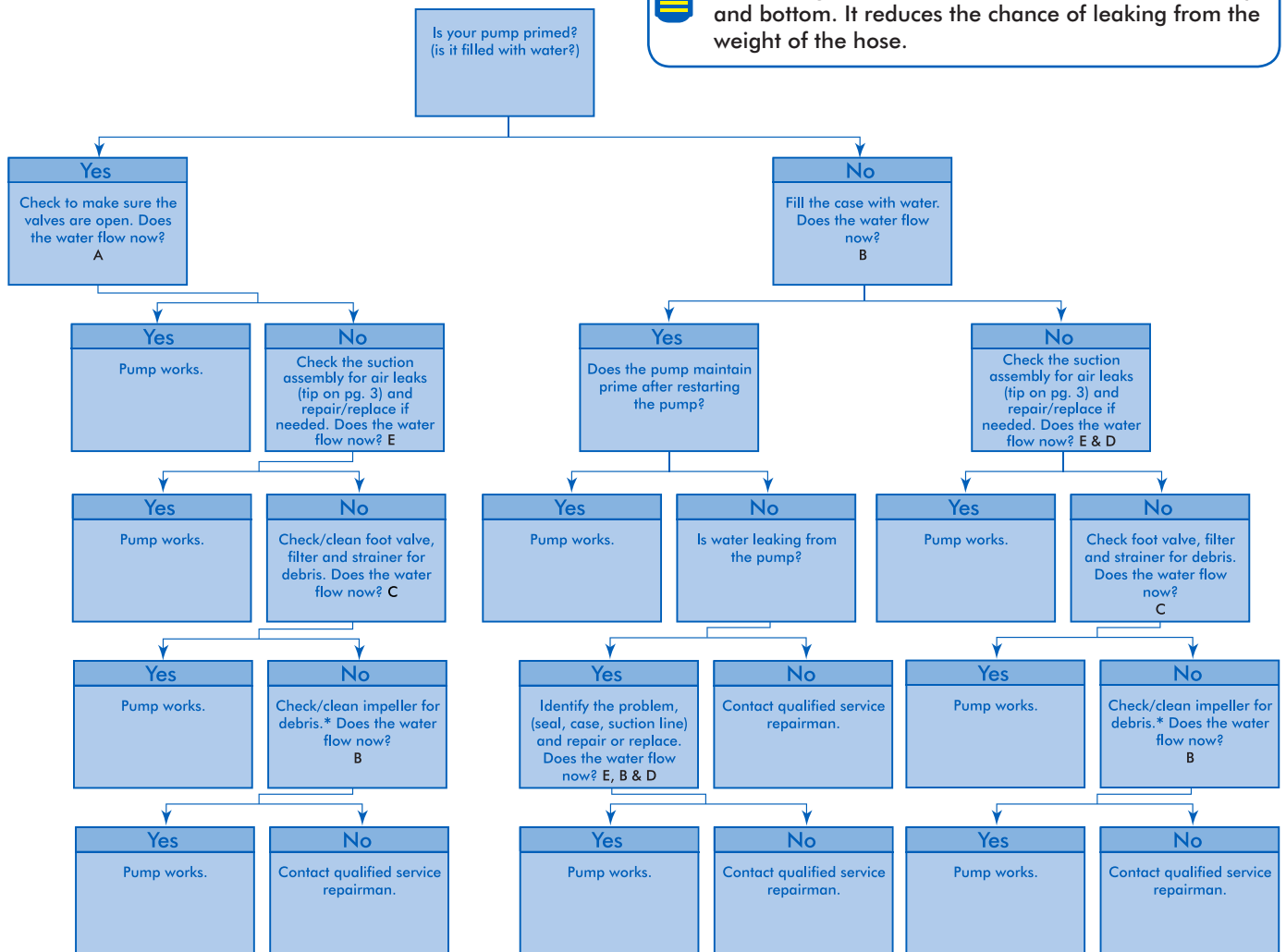

* Refer to the pump Owners Manual for tear down and reassembly instructions.

Troubleshooting Guide - Pump Surging (Flow Cycles)



Did You Know?

Union joint O-rings and cam fitting gaskets should be inspected or replaced every year or two. O-rings and gaskets can harden over time and become brittle, causing air leaks.

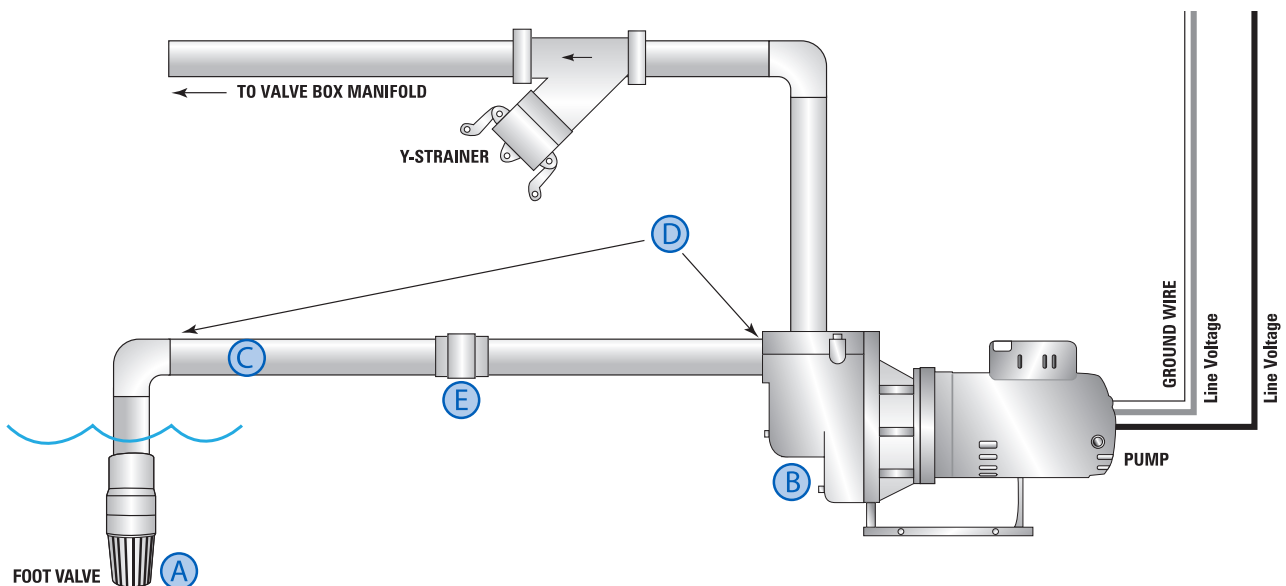
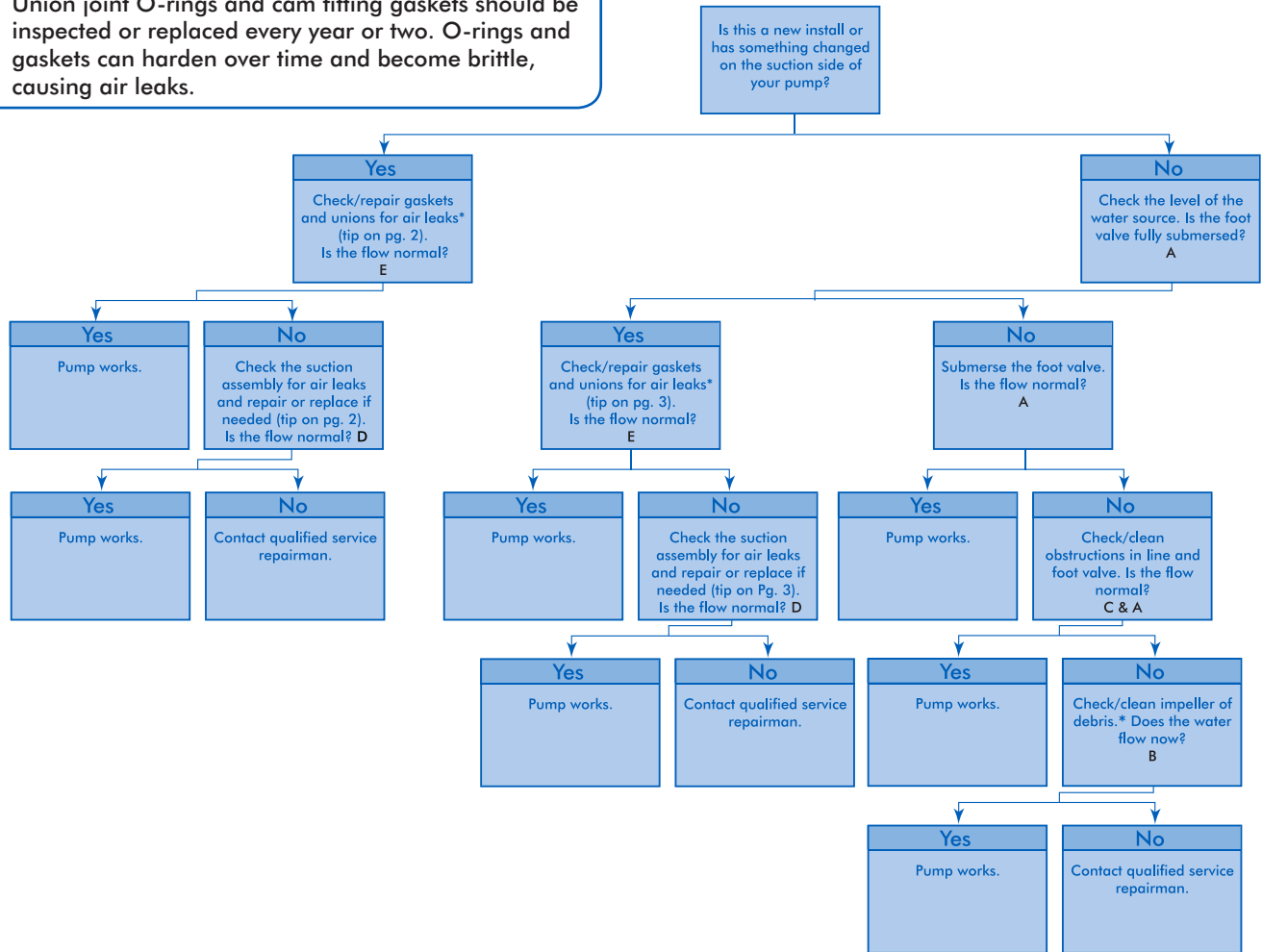

* Refer to the pump Owners Manual for tear down and reassembly instructions.

Troubleshooting Guide - Motor Hums



Did You Know?

To avoid an unnecessary trip, try jostling any debris inside the pump free before bringing your pump to a repairman. (Tip on pg. 3 "Clear Centrifugal Switch")

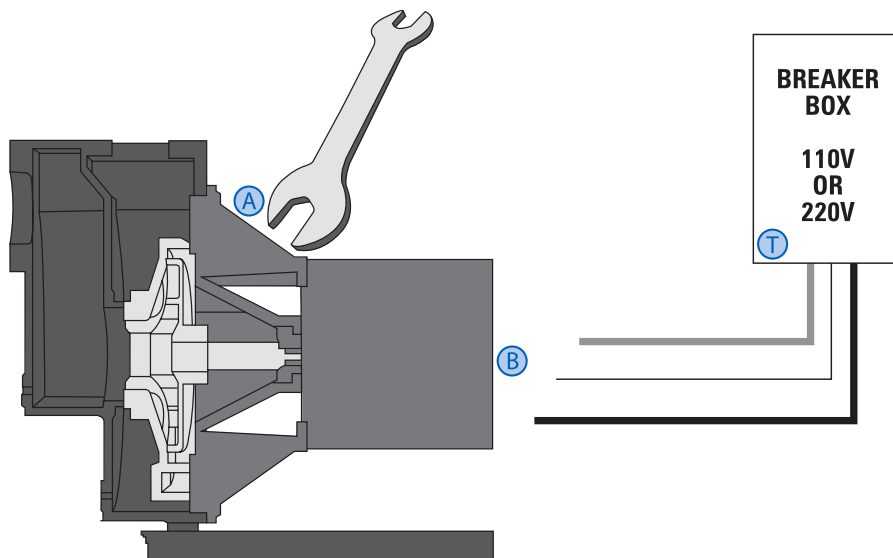
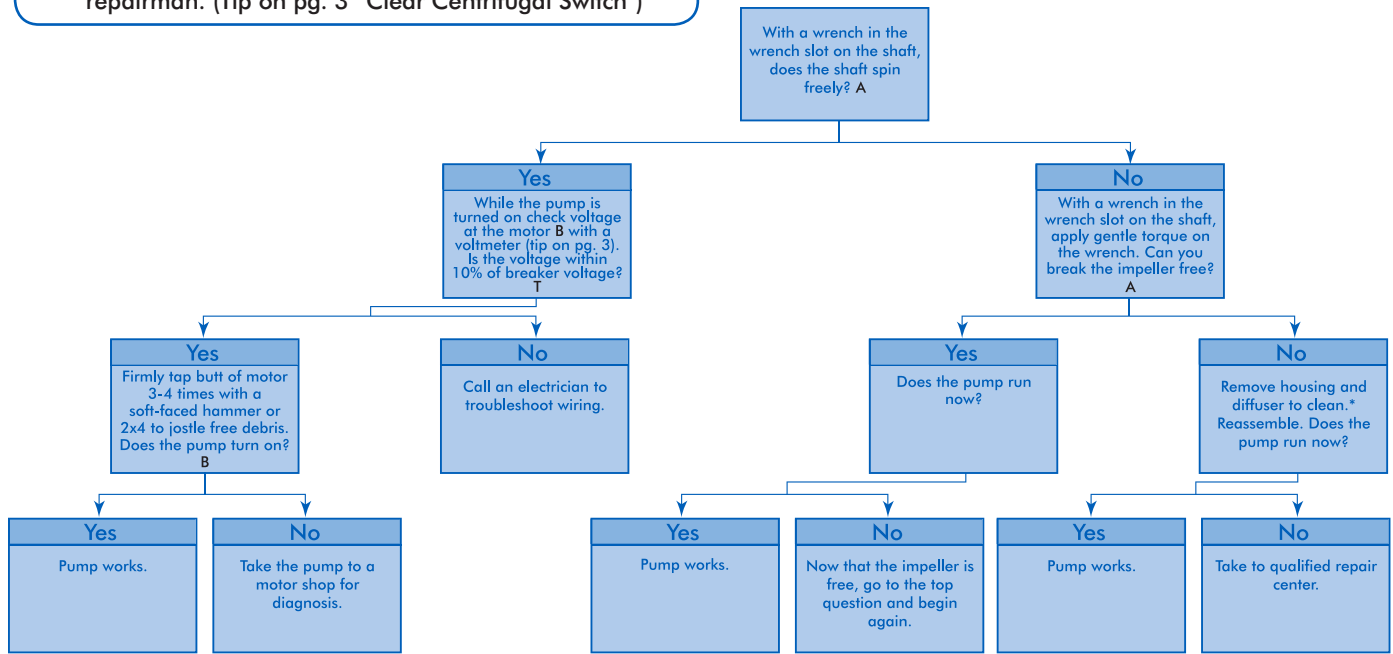

* Refer to the pump Owners Manual for tear down and reassembly instructions.

Troubleshooting Guide - Motor Does Not Run at All



Did You Know?

A motor may start with low voltage but cannot maintain running at low voltage. It will eventually wind down to a stop or burn the winding's insulation.

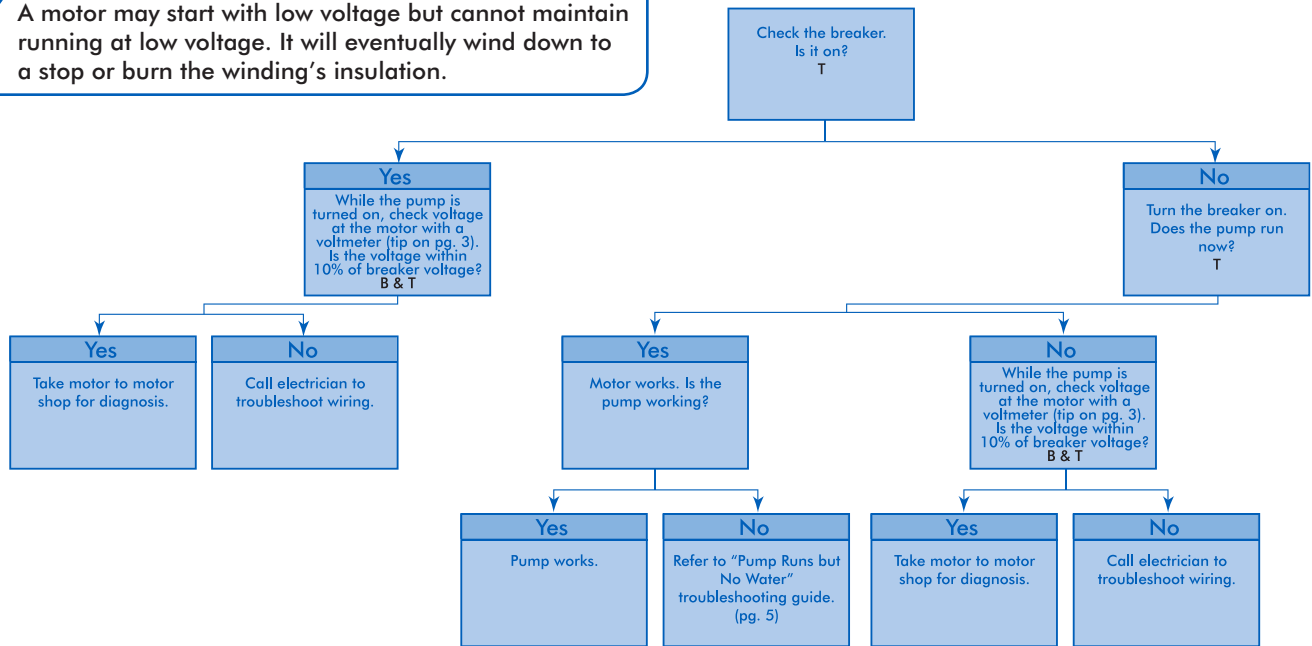

Did You Know?

A two-pole motor with 60 cycle current will run at a nominal 3600 RPM.

Note: For systems without a pump start relay, also see pg. 9. For systems with a pump start relay, also see pg. 10.

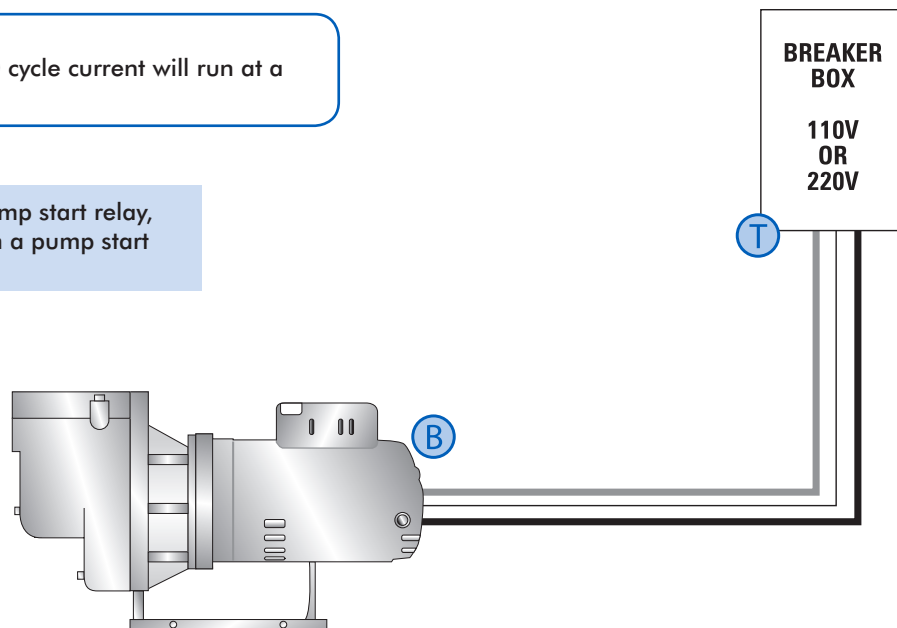

Troubleshooting Guide - Motor Cycles and/or Nothing Happens



Did You Know?

A capacitor start motor has an average of 1.5 times more torque during the start process.

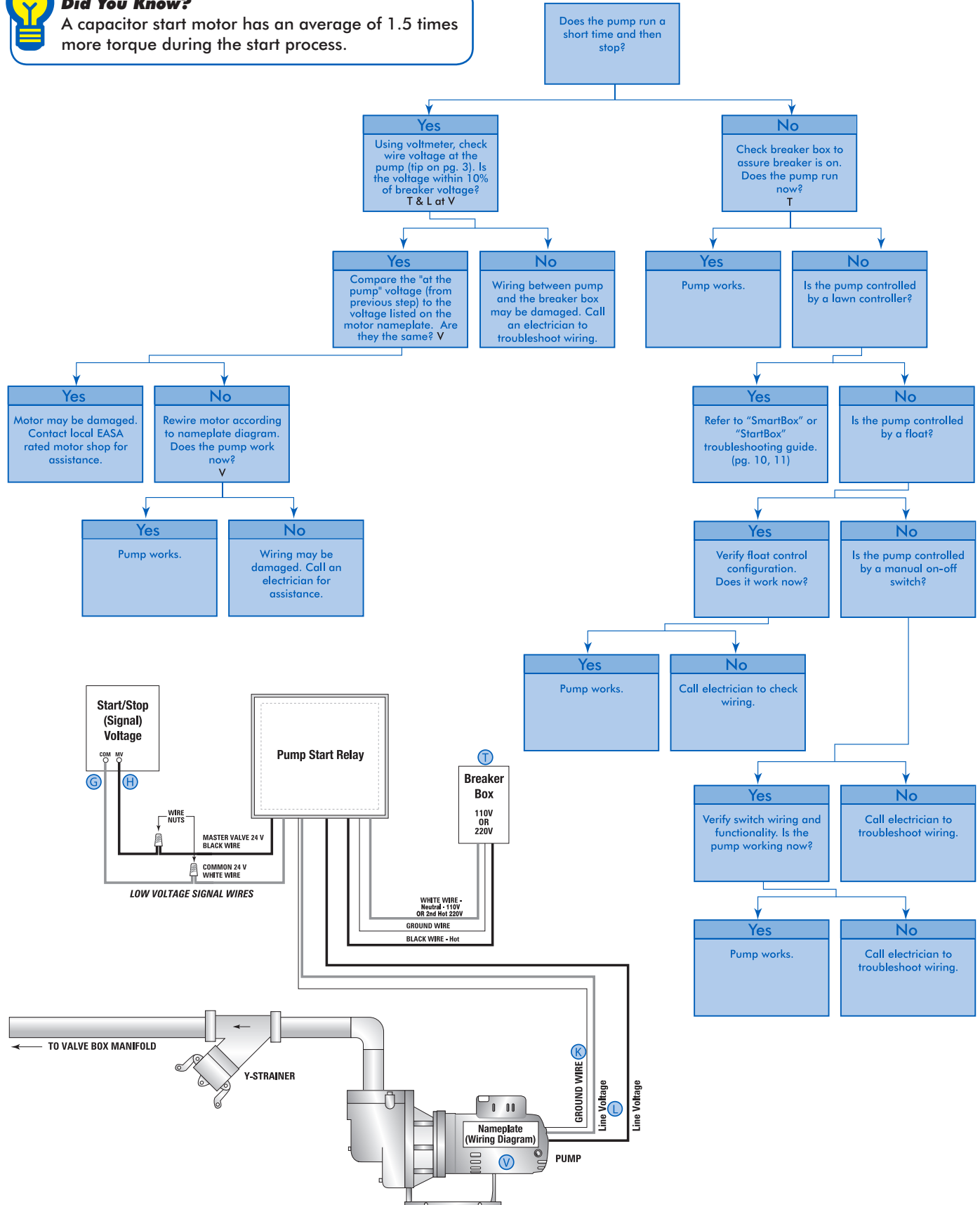

Troubleshooting Guide - StartBox



Did You Know?

A pump start relay can be signaled by a float switch.

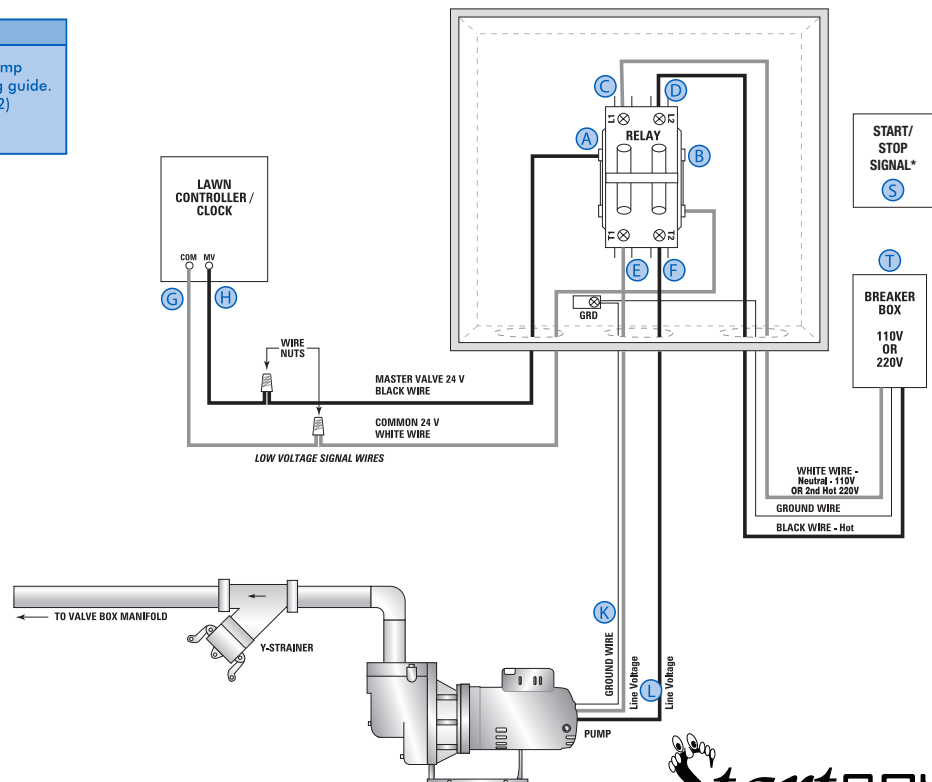
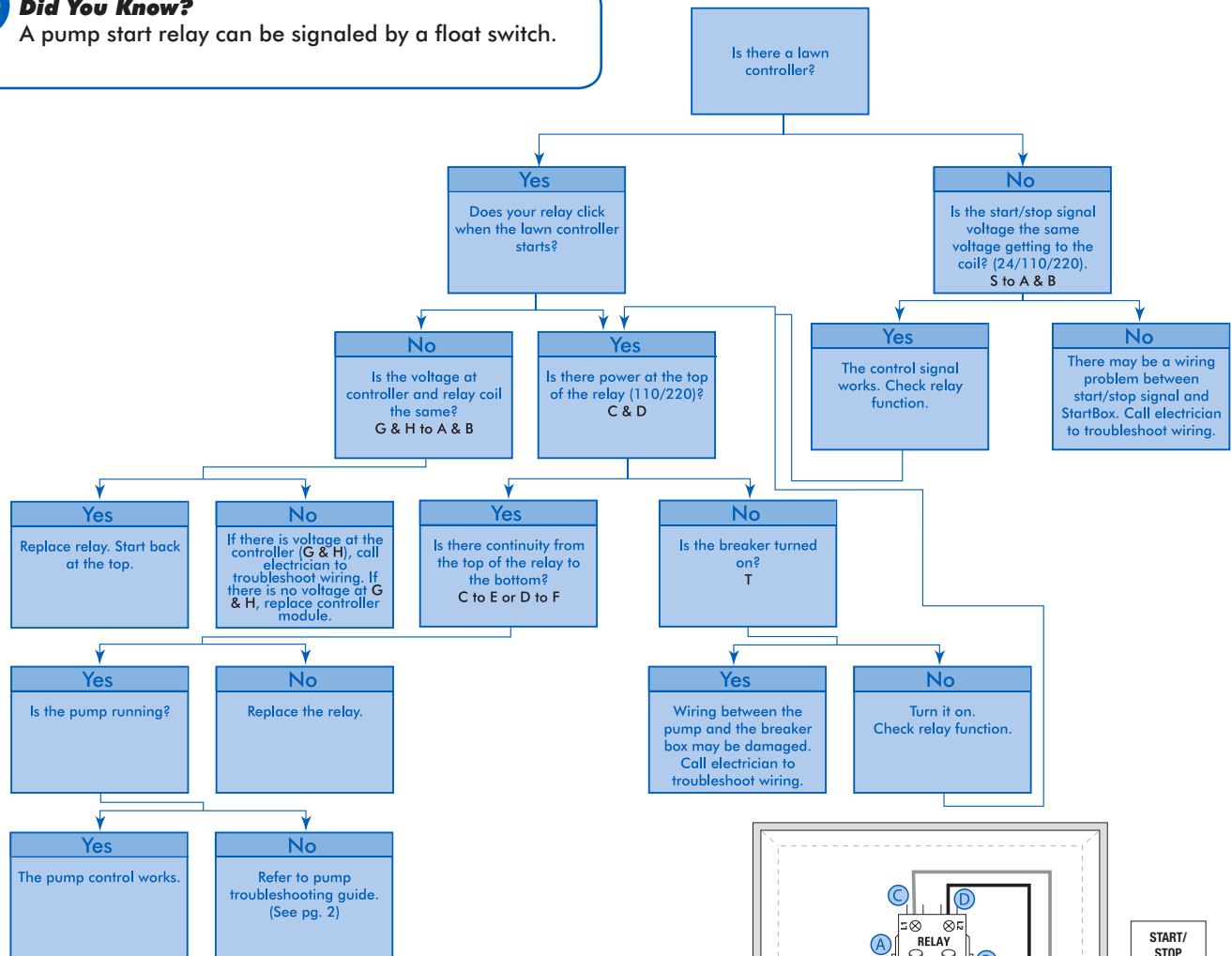

Note: Start/Stop signals include, but not limited to, float switches, HOA's, timers etc.

Note: The StartBox & SmartBox troubleshooting guides do not apply to 2-wire decoder systems.



Troubleshooting Guide - SmartBox



Did You Know?

During a normal "run" cycle, no lights should be lit on the time delay. Should a sensor detect a possible system problem, the "on" light will engage. If the system is shut down during a cycle both the "on" and "up" lights will be lit for the duration of the lawn controller cycle.

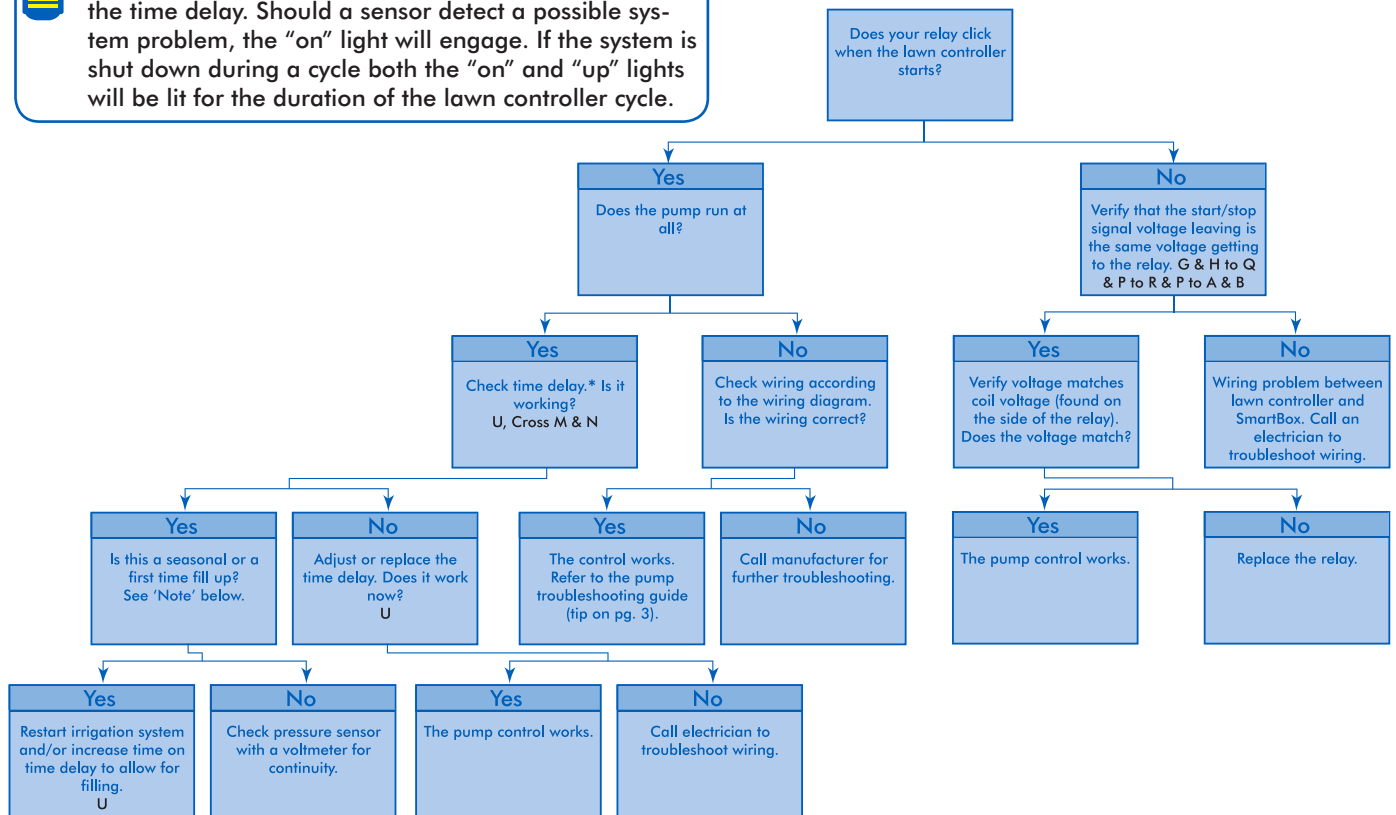

NOTE – OPTIONAL DOMESTIC VALVE: When a low pressure occurs a 24 VAC valve can be energized. Remove time delay relay from base by gently pulling it out. Connect 24 VAC valve, black wire to terminal 6 and connect white wire to terminal 2 with existing white wire, replace time delay relay by gently pushing it in.

* Turn the time delay down to 5 seconds. Next, cross the red and blue wire. The "on" light should turn on. After 5 seconds the system should shut off and both the "on" and "up" lights should be on.

Note: Filling system lines may require multiple run cycles to build enough pressure to initiate the sensor.

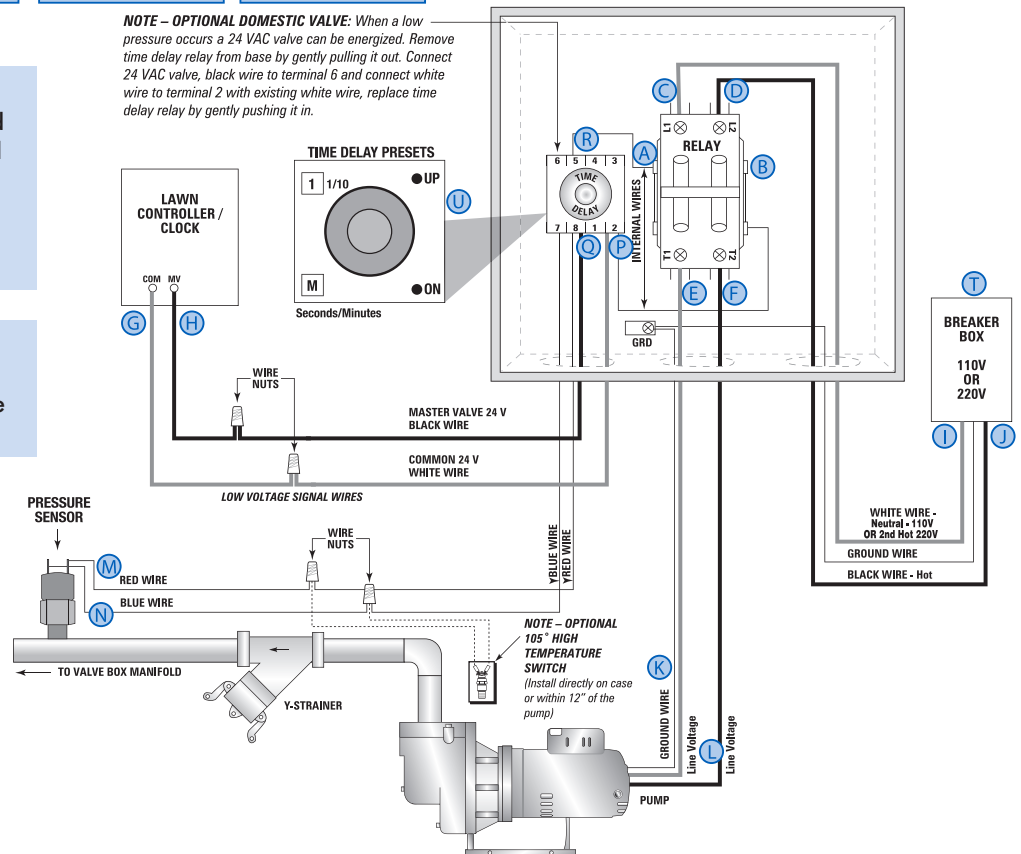

munro



11



9

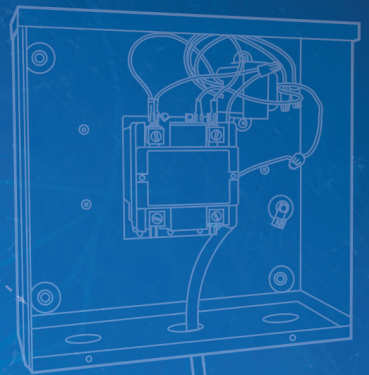

10



10

4

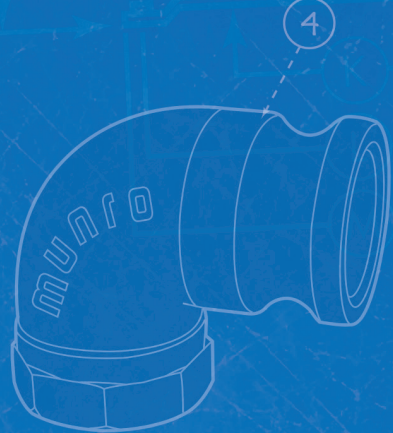

4



11

www.munrocompanies.com

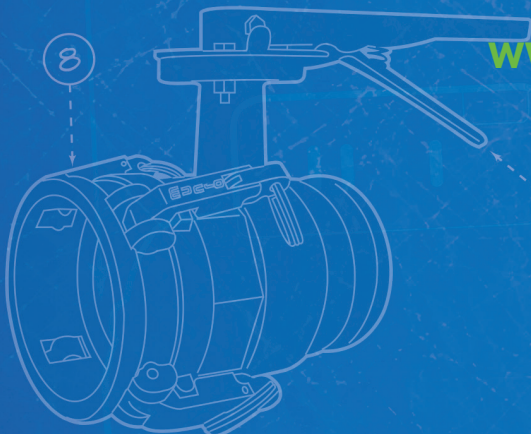

8

7



5

11

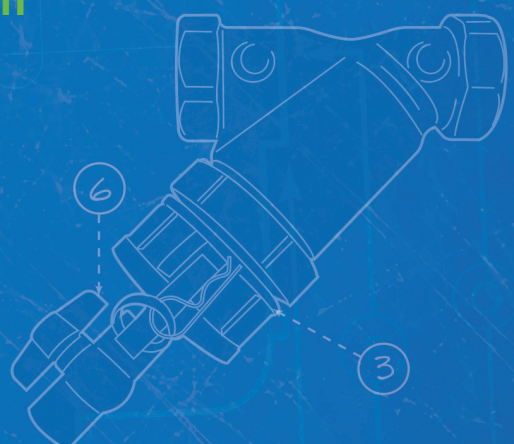

6

3



1

2



3

