



# **Munro**

**IRRIGATION  
CATALOG**

2024  
2025



## THE LEADER IN IRRIGATION



INTRODUCTION

CENTRIFUGAL

SUBMERSIBLE

SPECIALTY PUMPS

CONTROLS

PACKAGED SYSTEMS

HOSE

FITTINGS & FLANGES

VALVES

INDUSTRIAL GOODS

RESOURCES

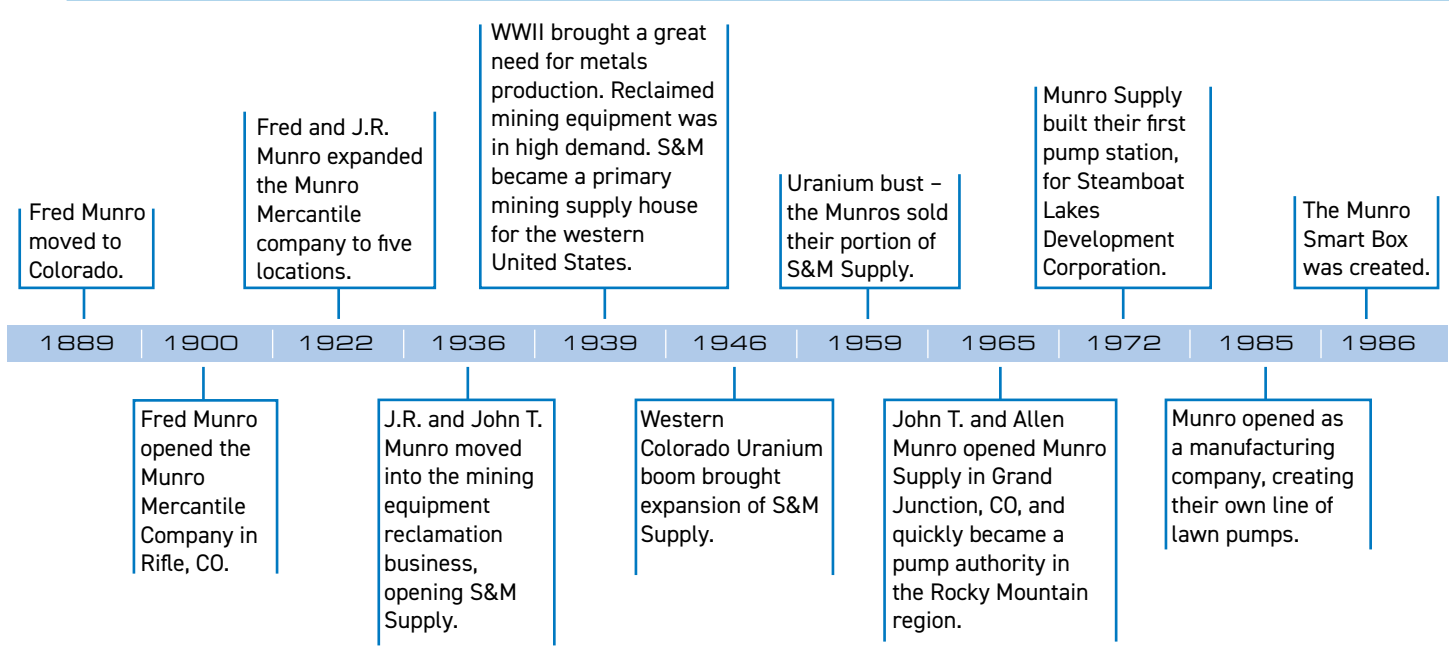

# INDUSTRY-LEADING SUPPORT AT EVERY STAGE

**A**s a long-standing, privately held, family-run company, we get to do things differently. We get to put our customers first, partnering with them for mutual success and profitability.

We take customer support and service seriously – from our outstanding technical customer support team, with decades of irrigation experience to help you select the right product or troubleshoot an issue, to our helpful sales team and responsive order fulfillment team. We are here for our customers every step of the way.

**HELPING YOU SELECT THE RIGHT SOLUTION** – We know how important it is to get things done right the first time. We provide you with a wide range of product options for pumps, controls and pump stations, so you get a solution that is a great match to your project’s performance requirements. To aid you through the selection process we offer a multitude of pump and pump control selection resources, plus a team of experts available through our pump hotline.

**INSTALL WITH CONFIDENCE** – When it comes to pump installs, our goal is to set you up for success. When questions or concerns arise, we want to be there to help solve the problem. Whether it’s walking you through your first ever installation, or helping you retrofit an existing system, we have the product knowledge and experience to support you.

**MAXIMIZING THE VALUE OF YOUR INVESTMENT** – Our after-sale support is unmatched, both at the factory and in the field. Together with our distributors, Munro goes above and beyond to provide industry-leading assistance. We provide a deep resource library of maintenance guides and tips, plus ongoing training for professionals at all levels.

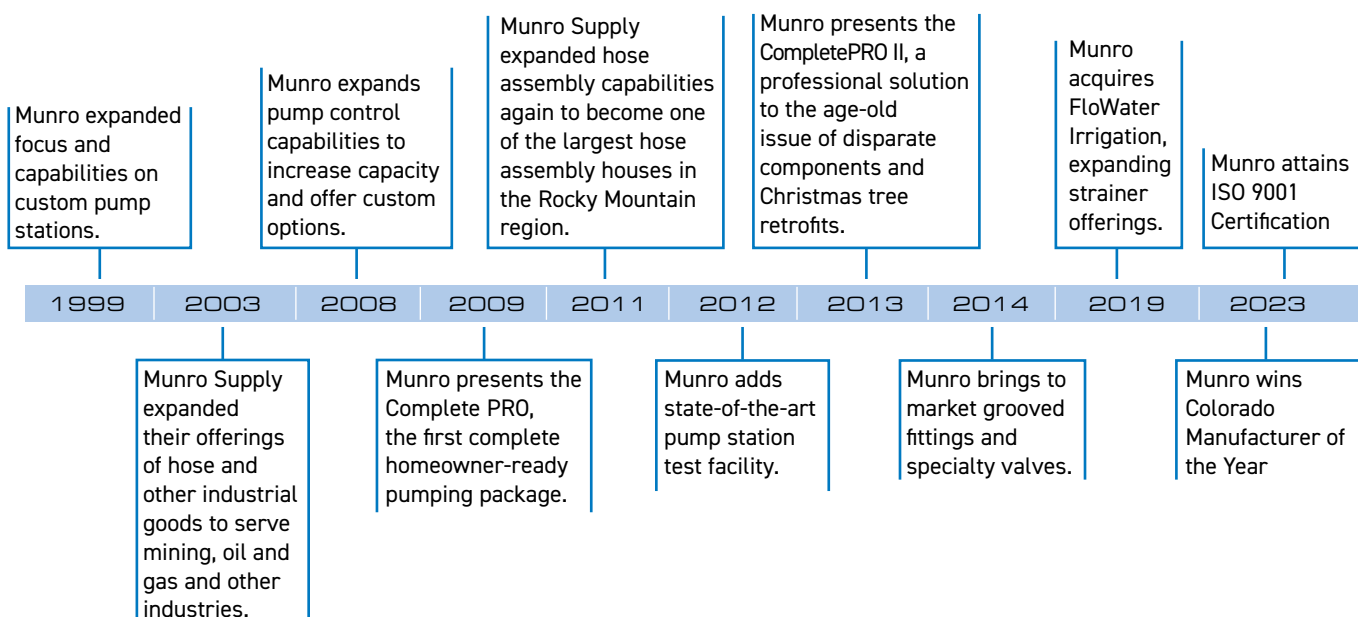

- INTRODUCTION
- CENTRIFUGAL
- SUBMERSIBLE
- SPECIALTY PUMPS
- CONTROLS
- PACKAGED SYSTEMS
- HOSE
- FITTINGS & FLANGES
- VALVES
- INDUSTRIAL GOODS
- RESOURCES

## HOT MUNRO PRODUCTS, HOT SALES OPPORTUNITIES

Munro offers products that solve problems and provide solutions. Each product is different, better, and Munro Professional-Grade Quality. Here is a quick round up of our hottest products.

### SELF-PRIMING CENTRIFUGAL PUMP **LP SERIES 3/4HP - 5HP**



P  
2

**Most rugged and reliable pump for professional irrigation installations.**

- Brass impeller (not plastic), cast-iron case.
- Higher GPM per HP = use a smaller pump size (less expensive) versus competitor.
- Built in convenient priming and draining ports.

### PACKAGED PUMP, ENCLOSURE + CONTROL **COMPLETE PRO II 3/4HP - 5HP**



P  
15

**Pump and control pre-assembled in a rust-resistant metal enclosure for “drop and go” installation.**

- Dramatically reduces installation time by up to 40%.
- Simplest installation – just connect suction and discharge lines and power supply.
- No need to build an enclosure.

## STANDARD PUMP START RELAY **STARTBOX**

**P  
77**

**Best-in-class pump start relay in a durable metal enclosure.**

- Models compatible with low-amp output irrigation controllers and 2-wire systems.
- Choice of coated metal or stainless steel cabinet.
- UL listed for industrial use.

## SMART PUMP CONTROL WITH PUMP PROTECTION **SMARTBOX**

**P  
80**

**Pump start relay + pump protection to prevent damage from run-dry (operating without water) and deadhead (pumping with no flow).**

- Pays for itself with one preventative shut-down.
- Models compatible with low-amp output irrigation controllers and 2-wire systems.
- Choice of coated metal or stainless steel cabinet.

### **FYI**

IF YOU ARE USING AN IRRIGATION CONTROLLER, YOU NEED A STARTBOX OR SMARTBOX TO START THE PUMP.

## Centrifugal

Irrigation & Booster .....	1
LP .....	2-10
Turf .....	11-13
Complete PRO II .....	15-20
Universal PRO Enclosure .....	21,22

## Submersible

Water Feature .....	25
RP .....	26-34
POND .....	35,36
Dewatering .....	37
FS .....	38-43
FSR .....	44,45
FSL .....	46,47
Residential Dewatering .....	48,49
Sump .....	50
Sump Series .....	51,52
FSE .....	53,54
Sewage & Effluent .....	55
FSE .....	56,57
FSA Vortex .....	58,59
FSA Stainless .....	60,61
FSG .....	62,63
Well Pumps .....	64
Multistage Bottom Suction .....	65,66
Deep Well .....	67-71
Well Pump Accessories .....	72,73
Well Pump Sleeve/Stand .....	74

## Specialty Pumps .....

### Controls

StartBox .....	77-79
SmartBox .....	80-82
Multi-Signal/One Pump Control Box .....	86
Multi-Pump/One Signal Control Box .....	87
TimeBox .....	88
Pressure Start Control Box Liquid Level Control Box .....	89
Liquid Level Control Box .....	90
BrainBox .....	83-85
DamBox .....	91,92
Control Panels .....	93,94
Custom Boxes .....	95-99
Control Accessories .....	100-106

### Packaged Systems

Complete PRO II .....	108-113
Simplicity .....	114,115
Stand Alone .....	116,117
Custom Prefabricated Stations .....	118,119

<b>Hose</b>	Hose .....	122-130
	Clamps .....	131,132
<b>Fittings &amp; Flanges</b>	Fittings.....	134-150
	Flanges .....	151
	Grooved Fittings .....	152-167
	HDPE .....	164-165
<b>Valves</b>	Butterfly.....	169,170
	Foot.....	171-173
	Gate.....	174
	Ball.....	175
	Check.....	176,177
	Float.....	178
	Flow Control.....	179
	Air Evacuating.....	179
	Unloader .....	180
	Relief.....	180
<b>Industrial Goods</b>	Strainers.....	181-184
	Gauges.....	185
	Pump Stands .....	186
	Pressure Tanks .....	186
	Industrial Goods.....	187
	Freeze Defeat.....	188
<b>Resources</b>	Typical Applications .....	190,191
	Pump Data Worksheets.....	192-194
	Hose Selection Worksheet.....	195
	Pump Station Request for Quote .....	196
	Control Worksheets.....	99,198
	Charts & Tables	
	Pump Controls Selection .....	199-204
	Friction Loss.....	205-210
	Wire Size .....	211,212
	Capacities of Steel Pipe.....	212
	Conversion Tables .....	213-215
	Measuring Tools .....	216
	Glossaries .....	217-232
	Installation Guides.....	233-238
	M95 HDPE Coupling.....	233,234
	M97 Transition Coupling.....	235,236
	M7705 Flexible Coupling.....	237,238
	Cut Groove Spec Sheets .....	239
	Roll Groove Spec Sheets.....	240
	Troubleshooting Guides .....	241-256
	Centrifugal Pumps & Controls .....	241
	Float Switch 101 .....	255
	Winterization .....	256
	Warranty.....	257,258
<b>Index</b> .....		259-262

INTRODUCTION

CENTRIFUGAL

SUBMERSIBLE

SPECIALTY PUMPS

CONTROLS

PACKAGED SYSTEMS

HOSE

FITTINGS & FLANGES

VALVES

INDUSTRIAL GOODS

RESOURCES

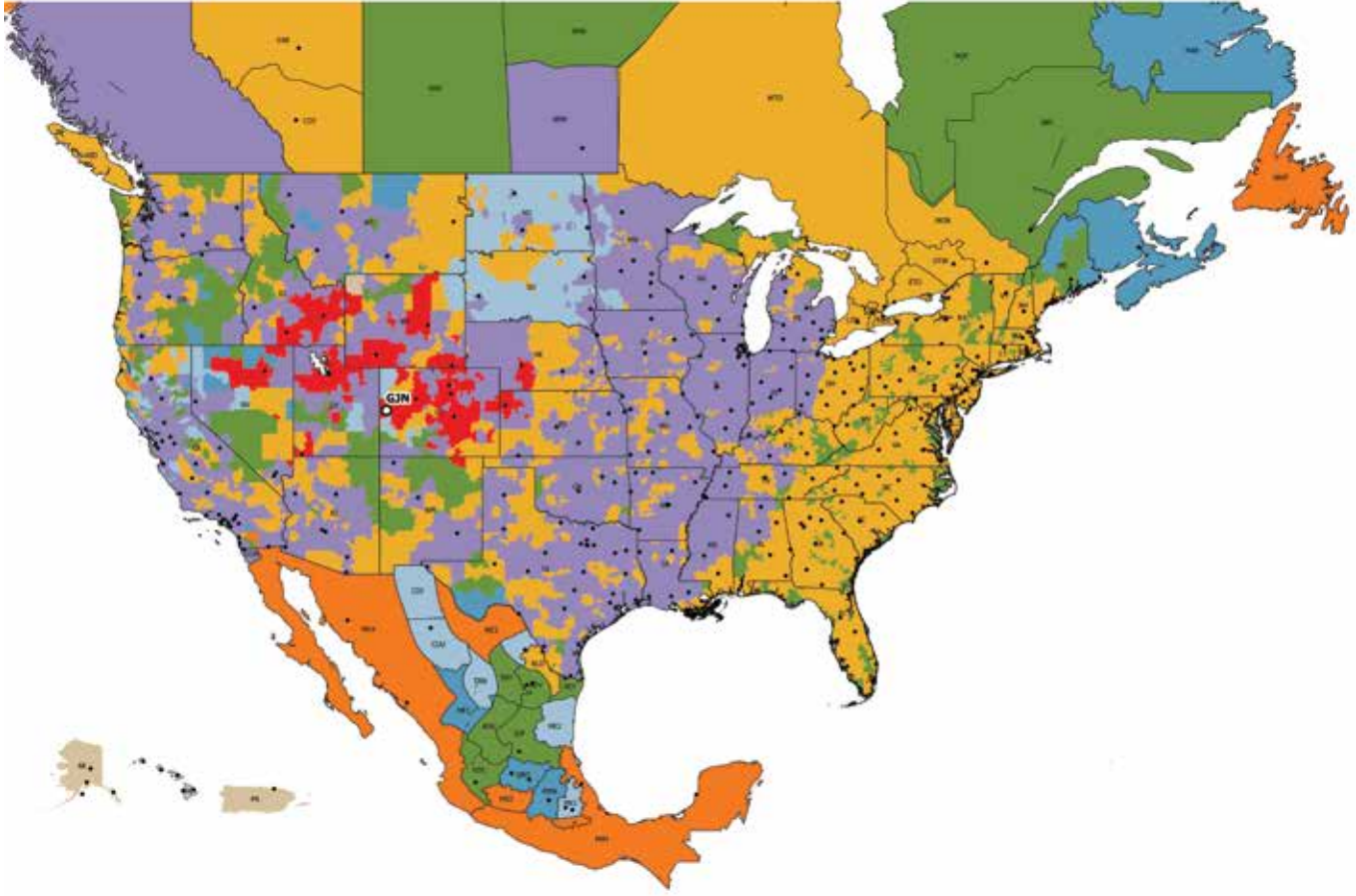

### Service Standards

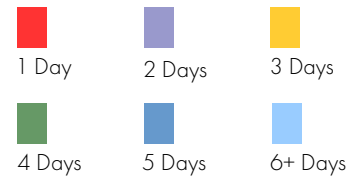

Estimated freight times when Fedex Priority is used - shipping from Grand Junction, CO.

Weather is uncontrollable variable.

As of 09/23 fedex.com



# TURF IRRIGATION CENTRIFUGAL PUMPS

## ABOUT CENTRIFUGAL PUMPS

### Benefits and Applications

Centrifugal pumps are flexible and have many uses. A centrifugal pump can handle muddy or dirty liquids and high temperatures. These pumps are most commonly used to move or increase pressure (boost) of liquid through a pipe or hose system and can be found in irrigation, water treatment, and even manufacturing environments.

Irrigation professionals use Munro pumps to draw water from lakes, ponds, cisterns, shallow wells and more. In addition, they are commonly applied to increase operating pressure (boost) in pressurized systems including domestic city water.

Examples of typical application set-ups can be seen on page 190-191.

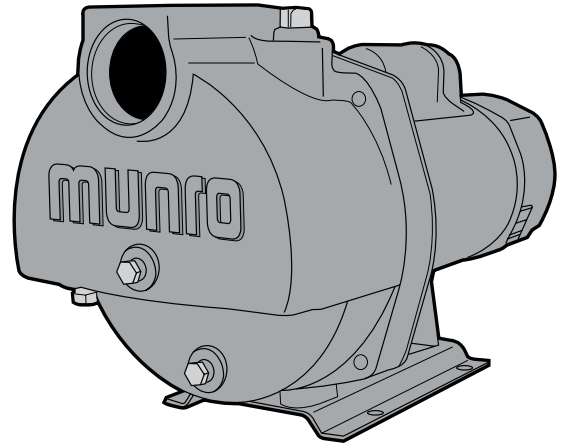

CENTRIFUGAL

## MUNRO PUMPS ARE EXCEPTIONAL

### Outstanding performance to horsepower

Check out our curves. Our pumps outperform common competitor units, time after time.

### Time-proven design re-engineered for maximum performance and longevity

With over 50 years experience in designing centrifugal pumps, the engineers at Munro studied the common failure points of competing units and meticulously addressed each with high-grade materials and intelligent design. We refuse to settle.

### Built tough in every component

A cast iron body and diffuser, standard on all sizes, mean these pumps are built to last.

### Upgraded products without upgraded cost

A brass impeller and carbon ceramic seal are standard for our full line, instead of pricey special-order upgrades.

### Easiest to install and maintain

Two priming ports, a sensor port and dual chamber drains makes maintenance quick and simple.



### Did You Know?

The first centrifugal pump was developed in 1475 – that’s what we call proven technology!

## Pick-A-Pump

TOTAL HEAD IN FEET	GALLONS PER MINUTE												PSI	
	20	30	40	50	60	70	80	90	100	110	120			
170	LP3005B/LP1502B	LP3005B												73.27
160	LP3005B/LP1502B	LP3005B/LP1502B	LP3005B	LP3005B										68.96
150	LP3005B/LP1502B	LP3005B	LP3005B/LP1502B	LP3005B	LP3005B	LP3005B	LP3005B							64.65
140	LP300B	LP300B	LP300B	LP1502B	LP3005B	LP3005B	LP3005B							60.34
130	LP200B	LP200B	LP300B	LP300B	LP1502B/LP300B	LP3005B	LP3005B	LP3005B						56.03
120	LP200B	LP200B	LP200B	LP300B	LP1502B/LP300B	LP300B	LP3005B	LP3005B	LP3005B					51.72
110	LP150B	LP200B	LP200B	LP200B	LP200B	LP300B/LP200B	LP300B	LP300B	LP3005B	LP3005B	LP3005B			47.71
100	LP100B	LP150B	LP150B	LP200B	LP200B	LP200B	LP300B	LP300B	LP300B	LP3005B	LP3005B	LP3005B		43.10
90	LP075B	LP100B	LP100B	LP150B	LP200B	LP200B	LP300B	LP300B	LP300B	LP3005B	LP3005B	LP3005B		38.79
80	LP075B	LP075B	LP100B	LP150B	LP150B	LP200B	LP200B	LP300B	LP300B	LP3005B	LP3005B	LP3005B		34.48
70	LP075B	LP075B	LP075B	LP100B	LP150B	LP200B	LP200B	LP200B	LP300B	LP300B	LP3005B	LP3005B		30.17
60	LP075B	LP075B	LP075B	LP075B	LP100B	LP150B	LP200B	LP200B	LP300B	LP300B	LP3005B	LP3005B		25.86
50	LP075B	LP075B	LP075B	LP075B	LP075B	LP100B	LP200B	LP200B	LP200B	LP300B	LP3005B	LP3005B		21.55

For larger flows or higher pressure than depicted, consult our technical support team at 1-800-942-4270.

## Munro LP Series – 3/4 - 3 hp



Designed specifically for turf irrigation, this self-priming pump provides outstanding performance to horsepower ratio. Our LP Series is truly heavy duty, offering standard high-end features that our competitors only offer as pricey add-ons. Professionals trust the LP Series to deliver trouble-free performance.

- **Brass impeller** – durable and low maintenance with the longest life in its class
- **Stainless steel wear ring** – eliminates impeller friction due to rust build-up and helps with efficiency
- **Cast iron body and internal components** – heavy duty for long-term performance and reliability

### COMMON APPLICATIONS

- Turf irrigation: Drawing water from ponds, lakes, streams, cisterns and shallow wells
- Booster: Boost domestic water pressure for use in irrigation
- Water transfer

### ADVANTAGES

**Durable and long lasting** – While many centrifugal turf irrigation pumps are made out of plastic, which wears and warps, our cast iron construction and brass impeller mean that our self-priming pumps are built to stand the test of time, even in more unusual or difficult environments. Testing in tough conditions shows Munro LP series pumps last up to four times as long as typical competitors products.

**Industry leading performance to horsepower** – In many cases a smaller horsepower Munro pump can be used in place of a larger horsepower pump from another manufacturer.

**Easy to install and maintain** – With two priming ports and a durable steel base plate, installing a Munro LP Series is a snap. When it's time to maintain or winterize the pump, you'll love our two drain plugs. A stainless steel wear ring reduces oxidation and friction, minimizing wear, spring start-up time and general repairs. If you do have to service the pump, stainless steel bolts and a dry-socket design provide easy access.

**BRASS IMPELLER** – Longest life in its class. Offers greatest durability and reduces costly maintenance vs traditional plastic impellers.

**CAST IRON CONSTRUCTION** – Designed for long term performance, season after season. No plastic case to warp or crack.

**SENSOR PORT** – Allows temperature monitoring to avoid costly maintenance issues.

**CERAMIC CARBON WITH BUNA RUBBER SEAL** – Proven tough, this seal is an industrial standard for challenging applications, including higher temperatures and more abrasive conditions.

**DUAL CHAMBER DRAINAGE** – Adds winterization and maintenance convenience.

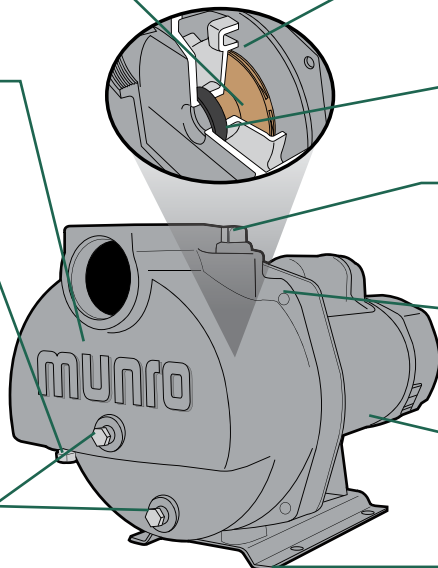

**CAST IRON DIFFUSER** – Assures durability for the life of the pump.

**STAINLESS STEEL WEAR RING** – Reduces springtime oxidation and impeller friction and improves efficiency.

**BUILT-IN PRIMING PORTS** – Reduces the number of additional fittings needed for monitoring or priming.

**STAINLESS STEEL BOLTS** – No more “busting knuckles” to remove bolts during maintenance.

**THERMALLY PROTECTED MOTOR** – Shut down protection protects motor from damage due to over amping.

**STEEL BASE PLATE** – Easiest, most stable mounting. Provides four handy bolt holes.

# Munro LP Series – 3/4 - 3 hp

Curve includes LP1502 (p.5) & LP3005 (p.8) for reference

## Curves

HORSEPOWER RANGE: 3/4 - 5

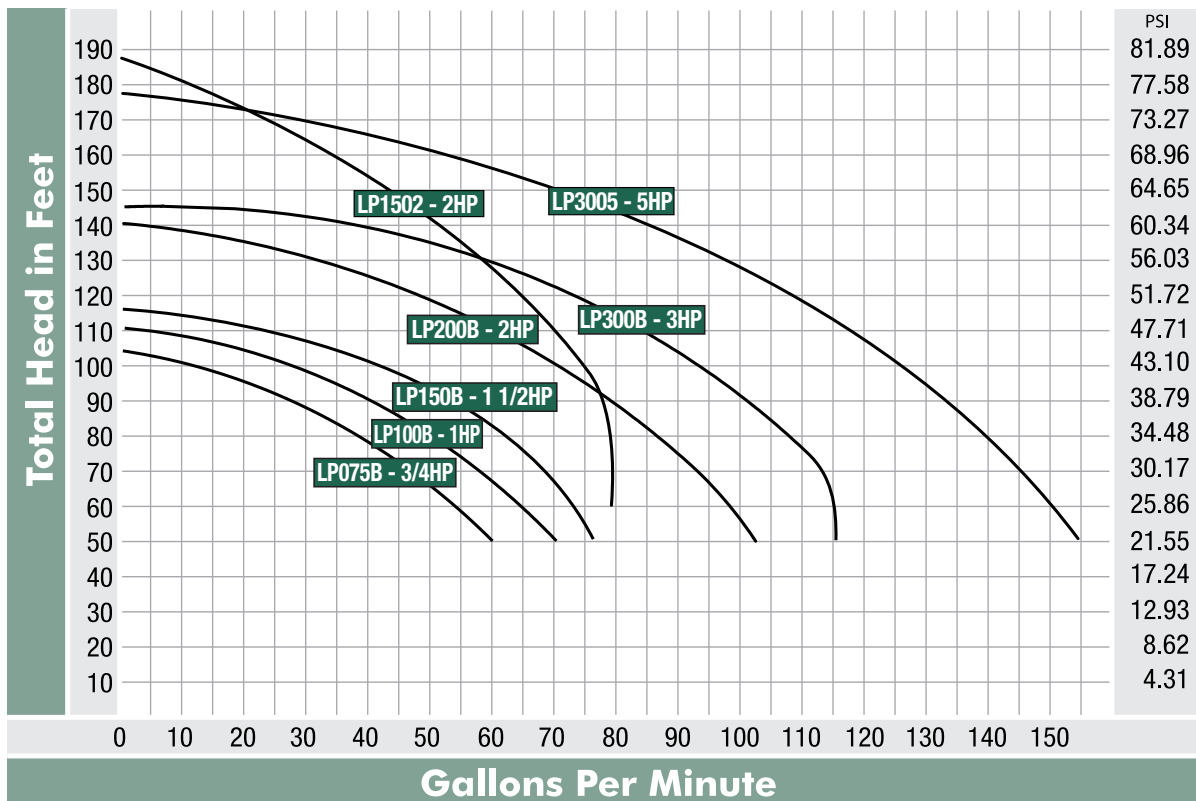

### Get everything you need!

- Add drain ball valves (p.175)
- Don't forget the pressure gauge (p.185)
- Protect your pump using Munro's SmartBox Pump Control (p.80-82)



### Filtration/Control Suggestion!

- S.S. Basket Strainer/Foot Valve (p.171)

## Performance

HP	Capacity - U.S. Gallons per Minute Discharge Pressure (PSI) at 5' Suction Lift										Max Case Pressure psi	Shut Off Pressure psi	Model Number
	20	25	30	35	40	45	50	55	60				
3/4	63	53	43	33	25						150	45	LP075B
1	73	65	57	47	35	18						47	LP100B
1-1/2	75	70	68	60	48	35						49	LP150B
2	102	98	92	82	74	61	52	40				60	LP200B
3	115	114	112	105	100	88	72	56	30			61	LP300B

Suction lift varies, depending upon elevation (altitude) and water temperatures. Max lift is 15 feet at 5000 feet elevation.



### Did You Know?

Pressure surges can create pressure spikes of up to 8 times working pressure, damaging system components, including your pump.

## Munro LP Series – 3/4 - 3 hp

CENTRIFUGAL

### Specifications – Pump

HP	Phase	Discharge	Suction	Approx Ship Weight lbs	Max Liquid Temperature	Model Number
3/4	1	1-1/2"	2"	66	180°	LP075B
1				72		LP100B
1-1/2				72		LP150B
2				80		LP200B
3				94		LP300B
3/4	3			57		LP075B3
1				62		LP100B3
1-1/2				68		LP150B3
2				70		LP200B3
3				76		LP300B3

Motor performance characteristics may vary. Verify all motor information on nameplate.

### Specifications – Motor

HP	Phase	Voltage	Hz	RPM	Motor Voltage (Factory) Connected	Service Factor Motor Amps						Model Number
						Single Phase			Three Phase			
						115V	208V	230V	208V	230V	460V	
3/4	1	115/208-230	60	3450	208/230V	14	7.4	7				LP075B
1						19.2	10.5	9.5				LP100B
1-1/2						20	11.7	10.1				LP150B
2						208/230	13	11.5				LP200B
3							19.5	17.7				LP300B
3/4	3	208-230/460	60	3450					2.9	2.9	1.4	LP075B3
1								4.1	3.8	1.9	LP100B3	
1-1/2								6	5.8	2.9	LP150B3	
2								7.3	6.7	3.3	LP200B3	
3								8.5	8.3	4.1	LP300B3	

### Dimensions

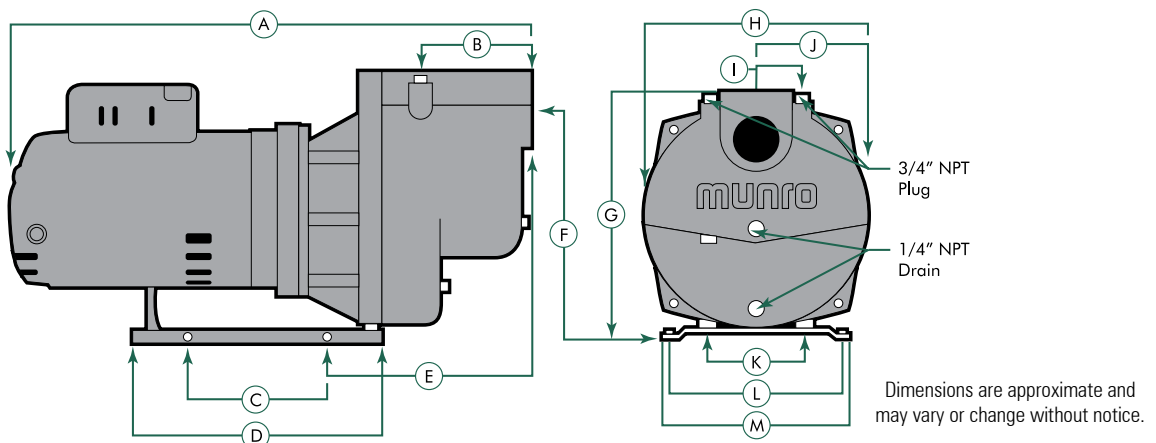

HP	A	B	C	D	E	F	G	H	I	J	K	L	M
3/4	19 3/4"	3 5/8"	4 1/4"	8 1/2"	7 1/2"	9 1/2"	10 7/8"	9 1/2"	2 3/8"	4 3/4"	2 5/8"	5 1/4"	6"
1	19 3/4"	3 5/8"	4 1/4"	8 1/2"	7 1/2"	9 1/2"	10 7/8"	9 1/2"	2 3/8"	4 3/4"	2 5/8"	5 1/4"	6"
1 1/2	19 3/4"	3 5/8"	4 1/4"	8 1/2"	7 1/2"	9 1/2"	10 7/8"	9 1/2"	2 3/8"	4 3/4"	2 5/8"	5 1/4"	6"
2	21 3/8"	3 5/8"	4 1/4"	8 1/2"	7 1/2"	9 1/2"	10 7/8"	9 1/2"	2 3/8"	4 3/4"	2 5/8"	5 1/4"	6"
3	20"	3 5/8"	4 1/4"	8 1/2"	7 1/2"	9 1/2"	10 7/8"	9 1/2"	2 3/8"	4 3/4"	2 5/8"	5 1/4"	6"

## Munro LP 1502 – 2 hp



This very unique pump offers multi-stage performance with single-stage simplicity. The Munro LP 1502 self-priming centrifugal pump provides higher operating pressure like a multi-stage pump without the additional maintenance concerns multiple impellers present. Built for maximum durability and longevity.

- **Brass impeller** – tough and long lasting, one brass impeller means you’ll see less maintenance than with other pumps that offer similar performance
- **Stainless steel wear ring** – eliminates impeller friction due to rust build up and improves efficiency
- **Heavy-duty motor** – lasts longer and provides application flexibility

### COMMON APPLICATIONS

- Clean water turf irrigation: Small to mid-size community or commercial turf irrigation
- High-pressure booster
- Water transfer

### ADVANTAGES

**Multi-stage performance with single-stage simplicity** – This self-priming pump is truly unique and in a class by itself, delivering over 50 gpm at 60 psi. The high-pressure capabilities of this pump can be compared to other brand’s multi-stage or 5hp pumps.

**Durable and long lasting** – Before the LP 1502, only a multi-stage pump could achieve this performance to horsepower ratio. However, additional impellers require a longer shaft, which puts more load on the motor bearing and creates maintenance issues, including misalignment and wear. Keeping the shaft short makes the pump more stable and durable. Add to this our cast iron construction and brass impeller and it’s clear that this is a pump made to stand the test of time, even in more unusual or difficult environments.

**Easy to install and maintain** – Two priming ports make the Munro LP 1502 easy to install and two drain plugs make winterization a snap. A stainless steel wear ring reduces oxidation and friction, minimizing wear and repairs.

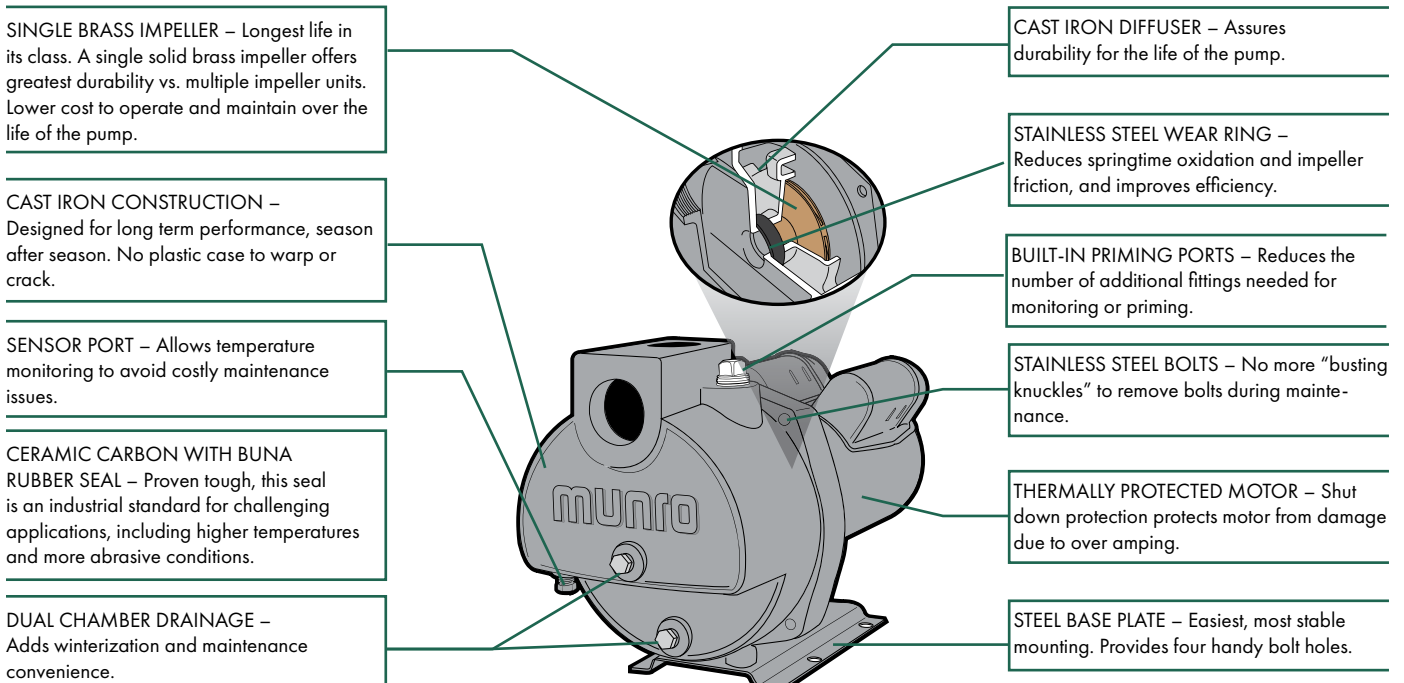

## Munro LP 1502 – 2 hp

CENTRIFUGAL

### Curves

HORSEPOWER RANGE: 2.5

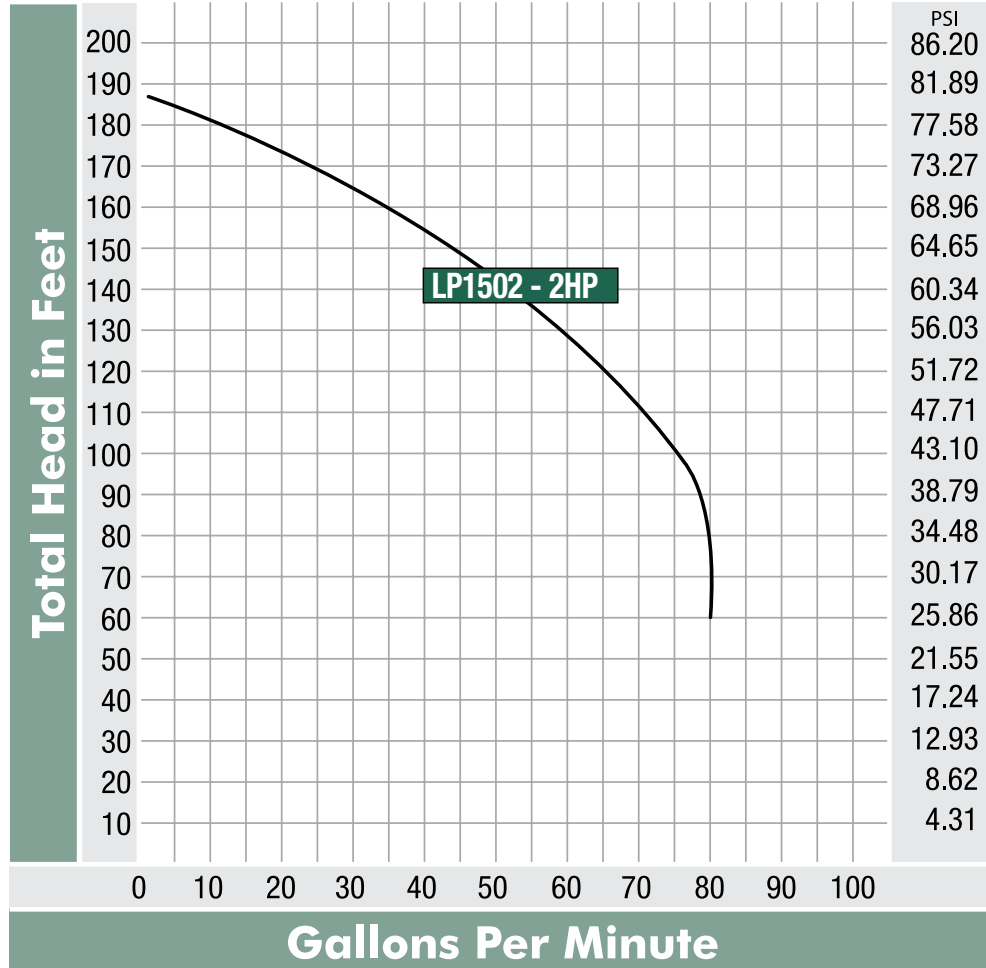

### Did You Know?

Mesh screens, filters, and strainers before the pump will increase the performance of your pump by reducing the debris entering your irrigation system.



### Filtration/Control Suggestion!

- 30 Mesh Y-Strainer (p.181)
- Munro SmartBox MPLC24T (p.80)

### Performance

HP	Capacity – U.S. Gallons per Minute Discharge Pressure (psi) at 5' Suction Lift									Shut Off Pressure psi	Model Number
	35	40	45	50	55	60	65	70	75		
2	80	73	73	67	61	56	44	34	18	80	LP1502B

# Munro LP 1502 – 2 hp

CENTRIFUGAL

## Specifications – Pump

HP	Phase	Discharge	Suction	Approx Ship Weight lbs	Max Liquid Temperature	Model Number
2	1	1-1/2"	2"	116	180°	LP1502B
2	3			105		LP1502B3

## Specifications – Motor

HP	Phase	Voltage	Hz	RPM	Motor Voltage (Factory) Connected	Service Factor Motor Amps						Model Number
						Single Phase			Three Phase			
						115V	208V	230V	208V	230V	460V	
2	1	208/230	60	3450	208/230	--	16	14.8	--	--	--	LP1502B
2	3	230/460				--	--	--	--	9.4	4.7	LP1502B3

For amperage ratings consult motor nameplate. Specifications subject to change without notice.

## Dimensions

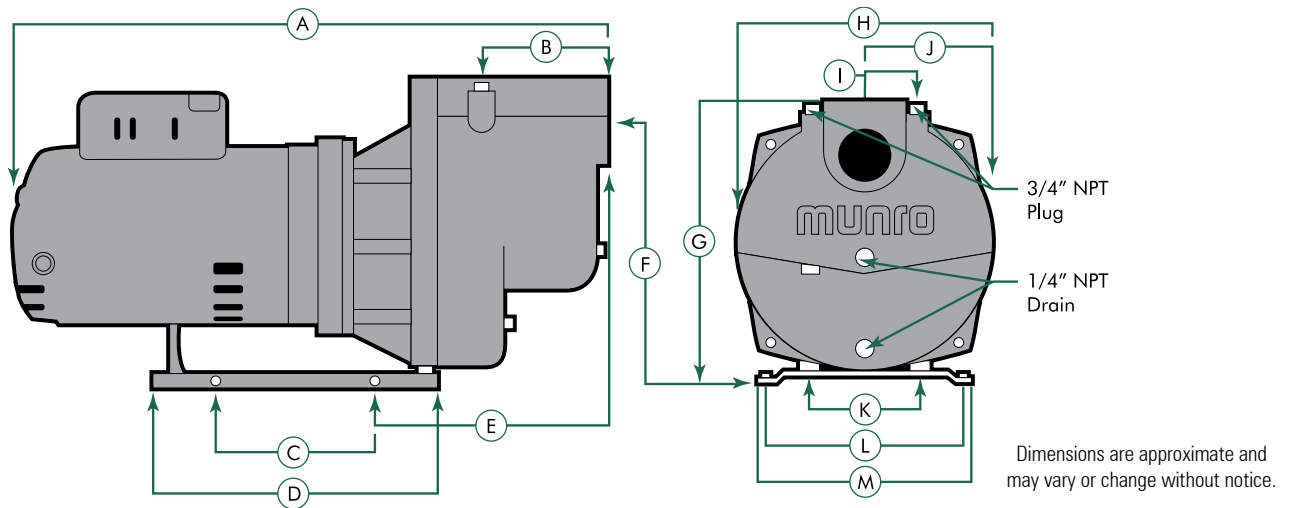

HP	A	B	C	D	E	F	G	H	I	J	K	L	M
2	20 7/8"	4 1/4"	7.95"	14"	9 1/4"	11 1/4"	13 1/2"	11 1/2"	3"	5 3/4"	4"	7"	8"

## Munro LP 3005 Series – 5 hp

CENTRIFUGAL



Perfect for mid-size turf applications like athletic fields or small pasture land, this 5 horsepower pump provides professional-grade performance, easy maintenance, and long life. Built with components proven to perform, this pump is a heavy-duty workhorse.

- **Brass impeller** – durable and low maintenance with the longest life in its class
- **Ceramic carbon with buna rubber seal** – proven toughness stands up to less than ideal situations
- **Heavy-duty motor** – lasts longer and provides application flexibility

### COMMON APPLICATIONS

- Turf irrigation: Residential, community or commercial turf irrigation
- High-pressure booster
- Water transfer

### ADVANTAGES

**Industry leading performance to horsepower** – The proof is in our curves. Compared to other 5 horsepower pumps, the Munro LP 3005 has much stronger performance. With high starting torque and an efficient run cycle, our pumps truly lead the pack.

**Durable and long lasting** – At this horsepower rating, performance requirements lead most pump manufacturers to use heavy-duty materials similar to those that come standard on all of our models. But look closely... we're building the toughest pumps around. Our cast iron construction and brass impeller mean that our self-priming pumps are built to stand the test of time, even in more unusual or difficult environments.

**Easy to install and maintain** – With two priming ports and a durable steel base plate, installing a Munro LP 3005 is a snap. When it's time to maintain or winterize the pump, you'll love our two drain plugs. A stainless steel wear ring reduces oxidation and friction, minimizing wear and repairs. If you do have to service the pump, stainless steel bolts provide easy access.

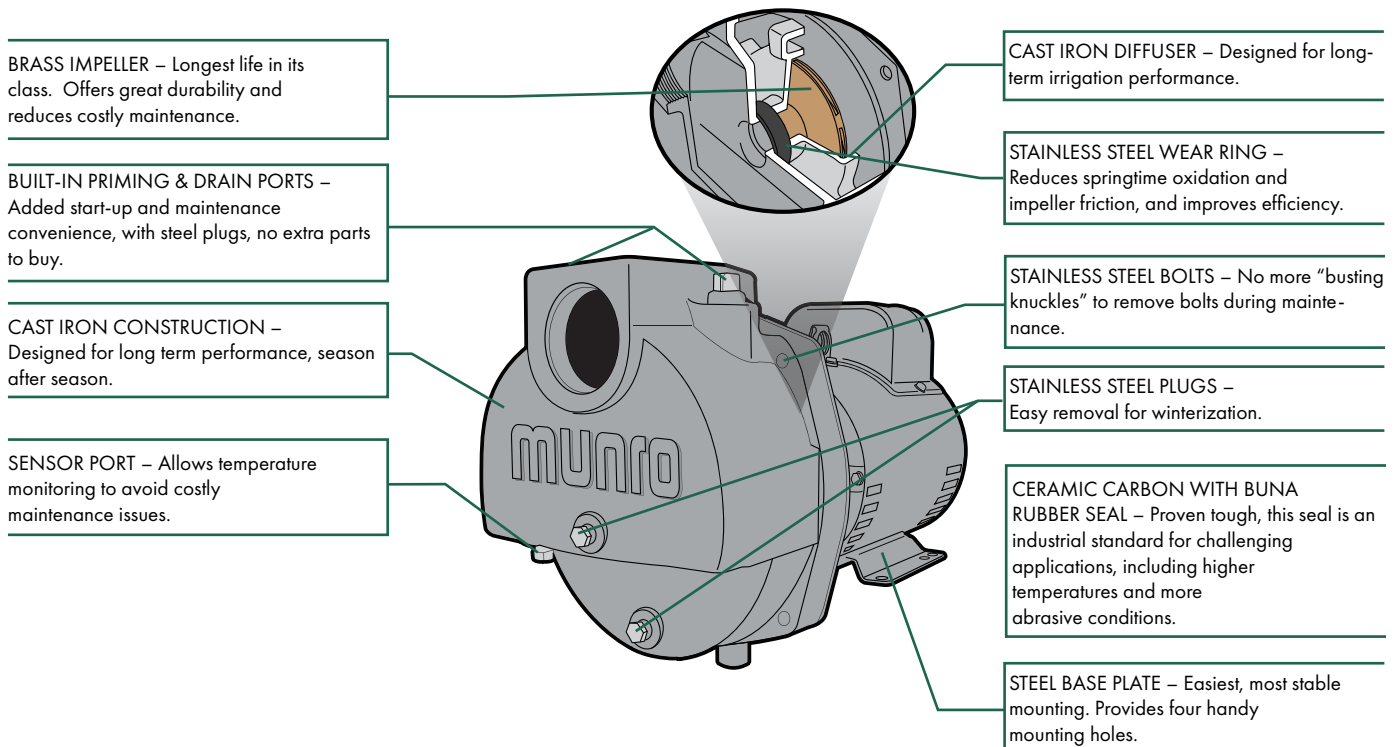

# Munro LP 3005 Series – 5 hp

## Curves

HORSEPOWER RANGE: 5

PHASE: 1

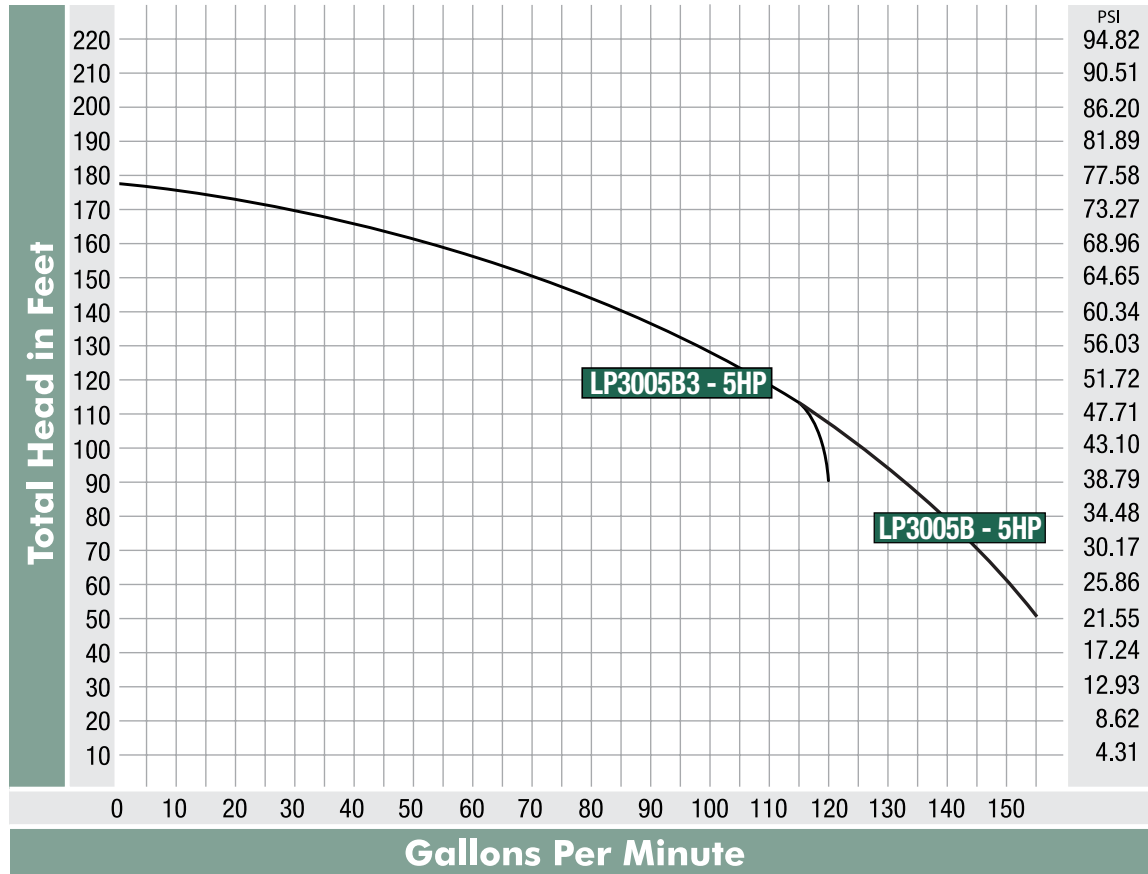

### Filtration/ Control Suggestion!

- 3" Foot Valve Strainer MBSA3CV (p.171)
- SmartBox Thermal Protection MPLC245T (p.182)

## Performance

HP	Capacity – U.S. Gallons per Minute Discharge Pressure (PSI) at 5' Suction Lift											Max Case Pressure psi	Shut Off Pressure psi	Model Number
	20	25	30	35	40	45	50	55	60	65	70			
5	--	--	145	137	132	123	110	98	85	67	47	100	75	LP3005B LP3005B3
	--	--	--	--	--	120	110	98	85	67	47			

Suction lift varies, depending upon elevation (altitude) and water temperatures. Max lift is 15 feet at 5000 feet elevation.

CENTRIFUGAL

## Munro LP 3005 Series – 5 hp

### Specifications – Pump

HP	Phase	Discharge	Suction	Approx Ship Weight lbs	Max Liquid Temperature	Model Number
5	1	3"	3"	151	180°	LP3005B
5	3			121		LP3005B3

### Specifications – Motor

HP	Phase	Voltage	Hz	RPM	Motor Voltage (Factory) Connected	Service Factor Motor Amps						Model Number
						Single Phase			Three Phase			
						115V	208V	230V	208V	230V	460V	
5	1	208/230	60	3450	230V	--	27	24.5	--	--	--	LP3005B LP3005B3
5	3	208-230/460				--	--	--	14	7		

For amperage ratings consult motor nameplate. Specifications subject to change without notice.

### Dimensions

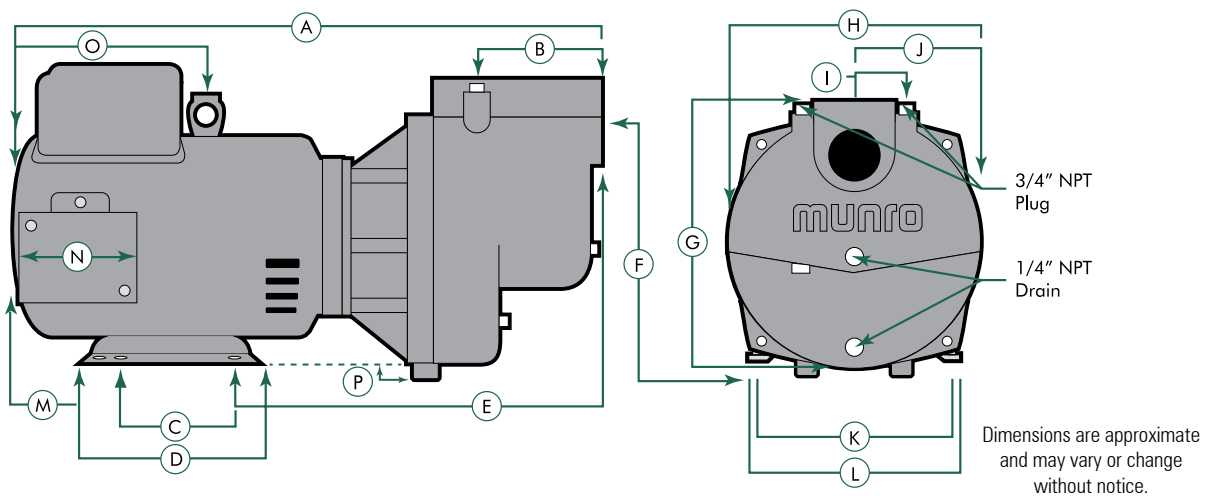

HP	A	B	C	D	E	F	G	H	I	J	K	L	M	N	O	P
5	21 3/4"	4"	4 1/2"	6 1/2"	13 1/2"	9 1/2"	12 5/8"	11"	3 1/8"	5 5/8"	7 1/2"	8 1/2"	2 1/2"	4 1/4"	7 1/2"	1 1/2"

## Munro MU Series High and Medium Head – 7 1/2 - 20 hp



These pumps are ideally suited to turf irrigation applications where greater flows and higher heads are required.

- **Bronze impeller** – the enclosed, single piece design is balanced and trimmed for specific operation
- **Mechanical shaft seal** – proven toughness stands up to less than ideal situations
- **Heavy-duty motor** – lasts longer and provides application flexibility

### COMMON APPLICATIONS

- Turf irrigation: Residential, mid-size community or commercial
- Water transfer

### ADVANTAGES

**Versatile** – These pumps can be used for a wide variety of applications, including irrigation, draining barges and tank cars, and dewatering mines or underground storage facilities. Homeowners use them for sprinkler systems and swimming pools. When it comes to moving water from one place to another, there’s no end to the jobs that a self-priming pump can handle!

**Quick start-up** – Because these pumps are self-priming, there is no additional work required to get the pump ready to operate. Just install, fill and go!



#### Filtration/ Control Suggestion!

- 4" PVC Basket Strainer MBSB400 (p.184)
- Control Panels MPCPG (p.93)

ENCLOSED BRONZE IMPELLER – Single piece design, balanced and trimmed for a specific operating range.

BRONZE SHAFT SLEEVE – Dissipates effects of shaft torque

CARBON CERAMIC MECHANICAL SHAFT SEAL – Reduces maintenance problems.

NEMA JM MOTOR – Provides a short shaft overhand and reduces axial strain on the motor bearings.

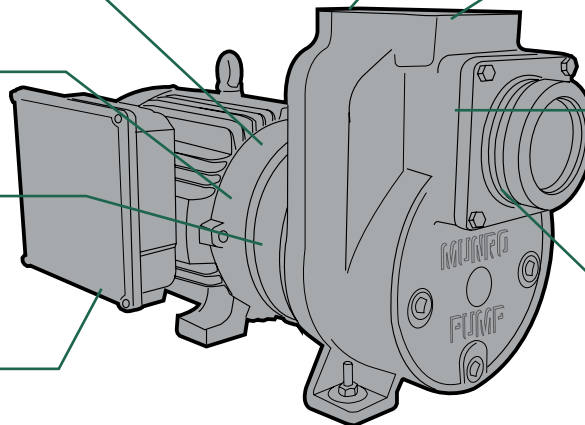

VERSATILE DISCHARGE CONFIGURATION – Threaded NPT and accepts bolt-on companion flange.

CAST IRON CASE – With built-in drain and priming plugs, the extra large priming chamber offers fast, trouble free priming.

BOLT ON SUCTION FLANGE – Allows for 3" or 4" NPT connection

BUILT IN CHECK VALVE – Prevents siphoning and need for re-priming.

## Munro MU Series High and Medium Head – 7 1/2 - 20 hp

### Curves

HORSEPOWER RANGE: 7 1/2 – 15

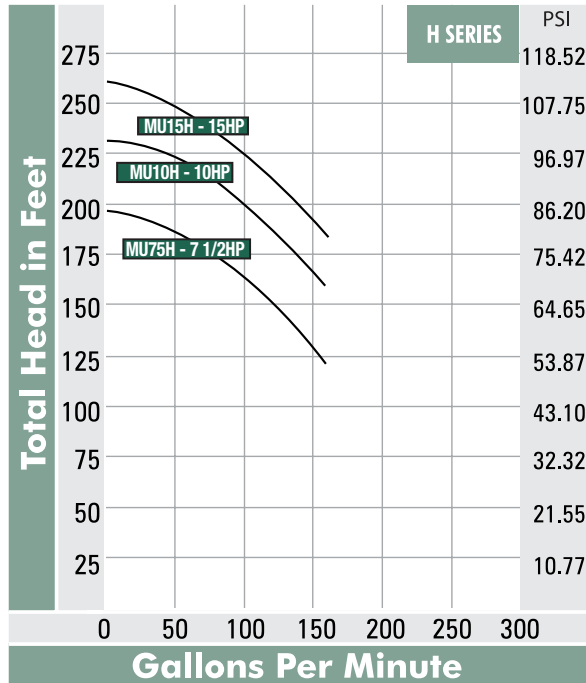

### Curves

HORSEPOWER RANGE: 7 1/2 – 20

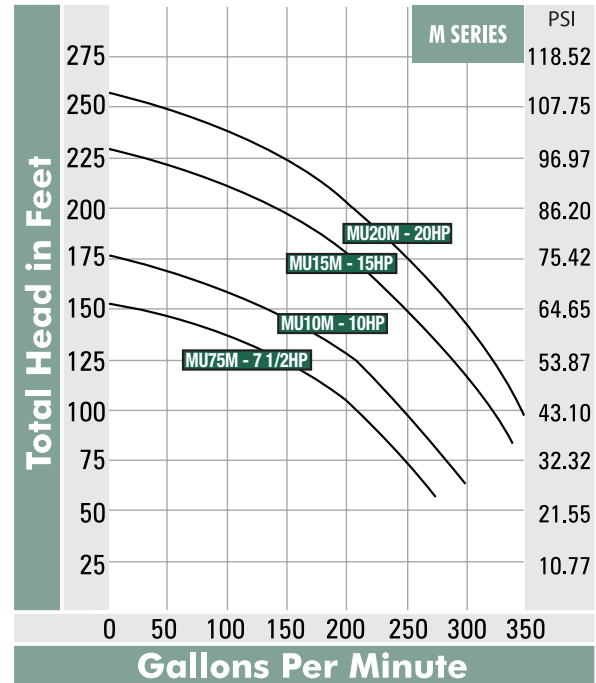

### Specifications – Pump – H Series

HP	Suction	Discharge	Approx Ship Weight lbs	Max Liquid Temperature	Max Case Pressure psi	Model Number
7.5	3"	3"	225	100°	120	MU75HS
7.5			174			MU75HT
10			229			MU10HS
10			197			MU10HT
15			210			MU15HT

### Specifications – Motor – H Series

HP	Phase	Voltage	Run Amps	Service Factor	Motor Type	Model Number
7.5	1	208-230/460	30.5-28.2/14.1	1.15	TEFC	MU075HS
7.5	3	208-230/460	19.2-17.3/8.67	1.15	ODP	MU075HT
10	1	208-230/460	41.8-38.8/19.4	1.15	TEFC	MU10HS
10	3	208-230/460	26.5-24.0/12	1.15	ODP	MU10HT
15	3	208-230/460	38.0-34.4/17.2	1.15	ODP	MU15HT

### Specifications – Pump – M Series

HP	Suction	Discharge	Approx Ship Weight lbs	Max Liquid Temperature	Max Case Pressure psi	Model Number
7.5	4"	3"	225	100°	120	MU75MS
7.5			174			MU75MT
10			229			MU10MS
10			197			MU10MT
15			210			MU15MT
20			241			MU20MT

# Munro MU Series High and Medium Head – 7 1/2 - 20 hp

## Specifications – Motor – M Series

HP	Phase	Voltage	Run Amps	Service Factor	Motor Type	Model Number
7.5	1	208-230/460	30.5-28.2/14.1	1.15	TEFC	MU075MS
7.5	3	208-230/460	19.2-17.3/8.67	1.15	ODP	MU075MT
10	1	208-230/460	41.8-38.8/19.4	1.15	TEFC	MU10MS
10	3	208/230/460	26.5-24.0/12	1.15	ODP	MU10MT
15	3	208-230/460	38.0-34.4/17.2	1.15	ODP	MU15MT
20	3	208-230/460	52.6-47.6/23.8	1.15	ODP	MU20MT

CENTRIFUGAL

## Dimensions

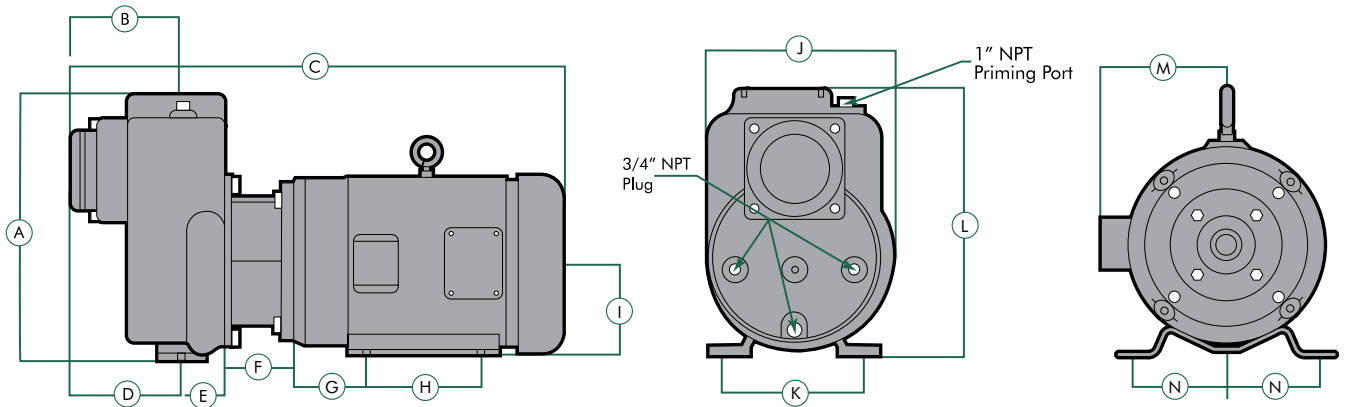

### Single Phase ODP

HP	A	B	C	D	E	F	G	H	I	J	K	L	M	N
7.5	15 1/4"	8 3/4"	26 5/8"	6 1/8"	2 3/4"	2 7/8"	3 1/2"	5 1/2"	5 1/4"	10 9/16"	7 15/16"	15 5/32"	9 5/16"	4 1/4"
10	15 1/4"	8 3/4"	27 1/4"	6 1/8"	2 3/4"	2 7/8"	3 1/2"	7"	5 1/4"	10 9/16"	7 15/16"	15 5/32"	9 5/16"	4 1/4"

### Three Phase ODP

HP	A	B	C	D	E	F	G	H	I	J	K	L	M	N
7.5	15 1/4"	8 3/4"	23 1/2"	6 1/8"	2 3/4"	2 7/8"	2 3/4"	4 1/2"	4 1/2"	10 9/16"	7 15/16"	15 5/32"	8 3/32"	3 3/4"
10	15 1/4"	8 3/4"	25 5/8"	6 1/8"	2 3/4"	2 7/8"	3 1/2"	5 1/2"	5 1/4"	10 9/16"	7 15/16"	15 5/32"	9 5/16"	4 1/4"
15	15 1/4"	8 3/4"	27 1/4"	6 1/8"	2 3/4"	2 7/8"	3 1/2"	7"	5 1/4"	10 9/16"	7 15/16"	15 5/32"	9 5/16"	4 1/4"
20	15 1/4"	8 3/4"	29 1/2"	6 1/8"	2 3/4"	2 5/8"	4 1/4"	8 1/4"	7"	10 9/16"	7 15/16"	15 5/32"	11"	5"

### Three Phase TEFC

HP	A	B	C	D	E	F	G	H	I	J	K	L	M	N
7.5	15 1/4"	8 3/4"	30 13/16"	6 1/8"	2 3/4"	2 7/8"	2 3/4"	4 1/2"	4 1/2"	10 9/16"	7 15/16"	15 5/32"	8 3/32"	3 3/4"
10	15 1/4"	8 3/4"	35 1/4"	6 1/8"	2 3/4"	2 7/8"	3 1/2"	7"	5 1/4"	10 9/16"	7 15/16"	15 5/32"	9 5/16"	4 1/4"
15	15 1/4"	8 3/4"	35 1/4"	6 1/8"	2 3/4"	2 7/8"	3 1/2"	7"	5 1/4"	10 9/16"	7 15/16"	15 5/32"	9 5/16"	4 1/4"
20	15 1/4"	8 3/4"	42"	6 1/8"	2 3/4"	2 5/8"	4 1/4"	10"	7"	10 9/16"	7 15/16"	15 5/32"	11"	5"

## Complete PRO II Series & Universal PRO Enclosure



Complete PRO II  
3/4 to 3 hp



Complete PRO II 5 hp  
with enclosure



Complete PRO II  
On Demand  
3/4 to 3 hp



Complete PRO II 5 hp  
Skid Mount

Visit [munropump.com/completevideo](http://munropump.com/completevideo)  
to see just how EASY irrigation pump installation can be!



Universal PRO Enclosure

## Munro Complete PRO II – 3/4 - 3 hp



The Munro Complete PRO II is a revolutionary complete pump package that includes a professional-grade pump, the highest quality pump control with built-in pump protection, and simplified plumbing connections – all housed in a unique enclosure designed specifically for a pump. With this complete solution, the days of purchasing and assembling numerous components and housing them in a makeshift enclosure are over.

Munro has incorporated best-in-class pump control with state-of-the-art pump protection features for the highest level of reliability and performance. With durable materials and advanced engineering, this long-lasting, quality product will be one that distributors and contractors will be confident in recommending to installers and end-users.

### ADVANTAGES

- **Easiest system to select & specify** – With only one product to buy or specify, you have everything you need for a complete pumping system.
- **Highest quality components** – Just like all of Munro’s products, the Complete PRO II is made with high-quality materials for a long, trouble-free service life.
- **Fast and easy installation** – This product ships complete, with everything you need to quickly adapt to any existing piping or electrical. All you have to do is hook it up and plug it in – it’s really that easy!



**Did You Know?**  
Munro Complete Pro IIs offer a two year warranty.

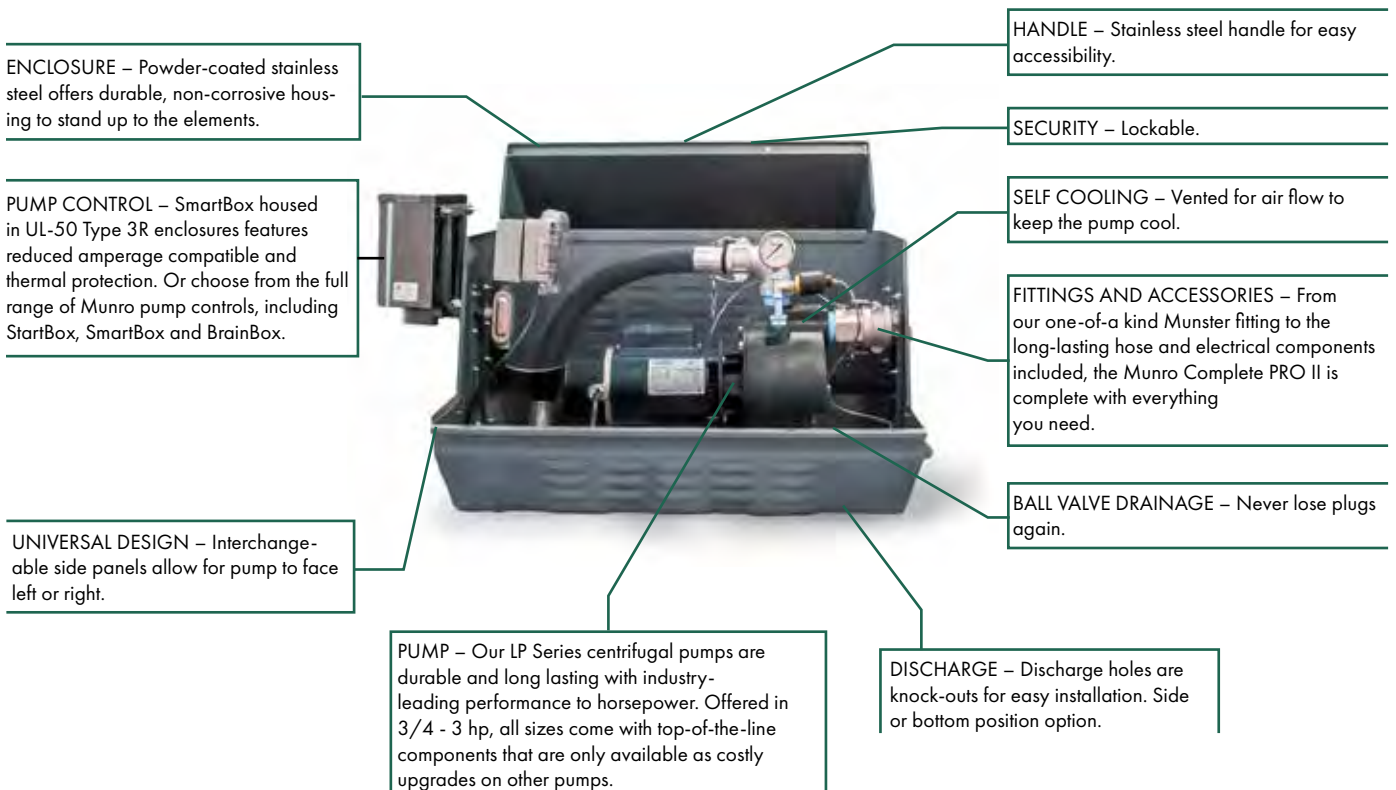

## Munro Complete PRO II – 3/4 - 3 hp

### Curves

HORSEPOWER RANGE: 3/4 - 3

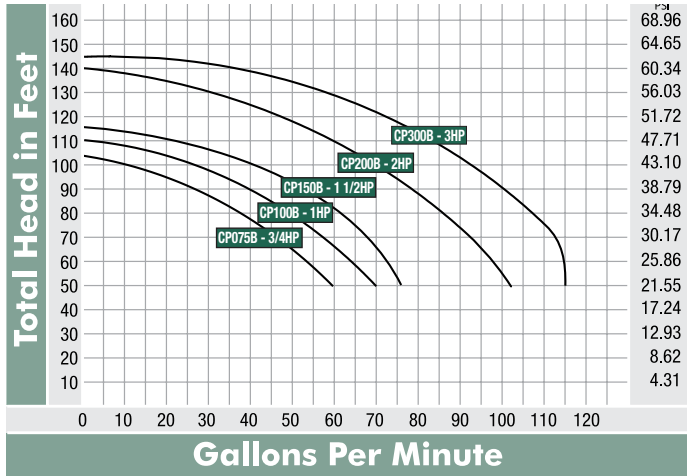

HORSEPOWER RANGE: 2

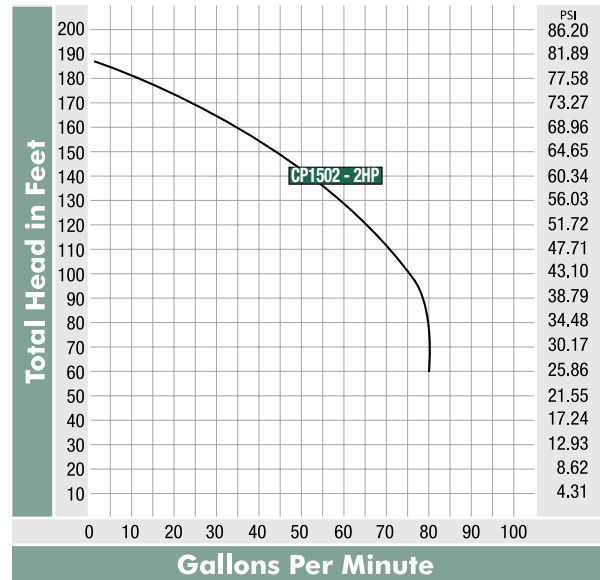

### Specifications

HP	Phase	Standard Voltage	Discharge	Suction	Dimensions			Control	Approx Ship Weight lbs	Model Number
					Height	Length	Depth			
Complete PRO II – SmartBox MPLC242W22TS										
3/4	1	208-230	1 1/2"	2"	23 1/4"	36"	19 1/2"	SmartBox	109	CP075B
1									110	CP100B
1 1/2									120	CP150B
2									128	CP200B
3									143	CP300B
3/4	3*	208-230							115	CP075B3
1									121	CP100B3
1 1/2									117	CP150B3
2									128	CP200B3
3									137	CP300B3
2	1	208/230	168	CP1502B						
2	3	208/230	163	CP1502B3						

Contact Munro for other control or voltage options.  
 Lead times vary for specialty or custom options.  
 Must specify line voltage for 3 phase.  
 All measurements are approximate and are subject to change.  
 See p.4 for complete specifications for LP series pumps.  
 \*SmartBox varies by hp on 3ph.



#### Did You Know?

Complete PROs are also available with BrainBox or Pressure Start controls. Contact Munro for more info – 800.942.4270

# Munro Complete PRO II – On Demand



The easiest installation is now available with on demand controls!

The Munro Complete PRO II is already the total package, complete with a professional grade pump, the highest quality pump control, and simplified plumbing connections, all housed in a unique enclosure designed specifically for a pump.

Now, the Complete PRO II is available with our Pressure Start Control Box. Grab your hose and water your plants or wash down the driveway. The pump will automatically run on your demand for water. No need for a pressure tank! On demand controls utilizes flow and pressure to detect water demand.

### COMMON APPLICATIONS

- Recommended for: drawing water from ponds, lakes, streams, cisterns and shallow well
- Other uses: water transfer

### ADVANTAGES

- **Easiest system to select & specify** – One professional package includes pump, smart controls and enclosure
- **Trouble-free components** – High quality materials for a clean, durable installation you will be proud of
- **Hassle-free installation** – Comes complete. No parts to forget, no need for shortcuts. No fuss, no errors
- **2-year warranty** – Upgrade to CompletePRO II and get your warranty to go from 1-year to 2 years.

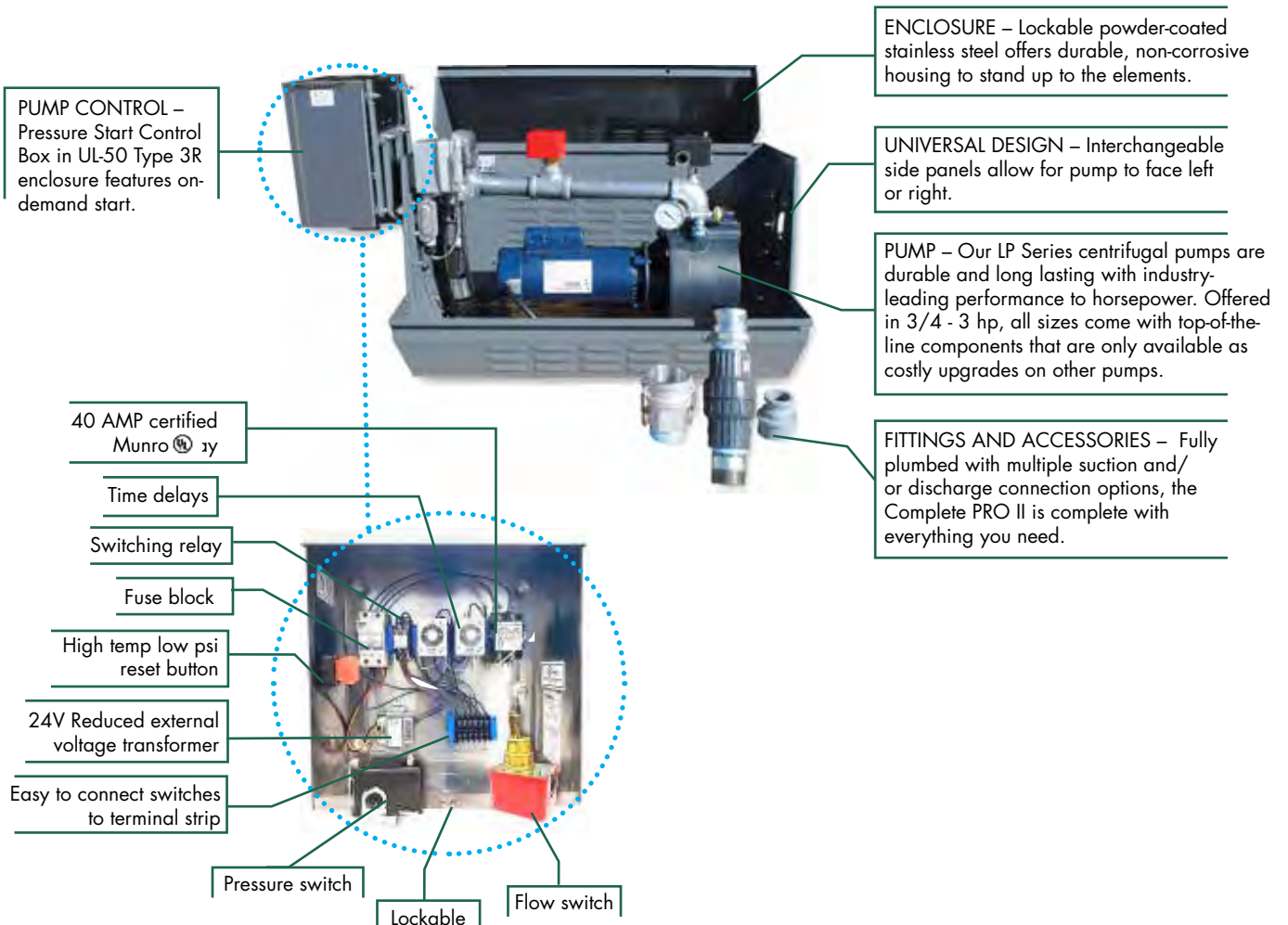

## Munro Complete PRO II – On Demand

### Curves

HORSEPOWER RANGE: 3/4 - 3

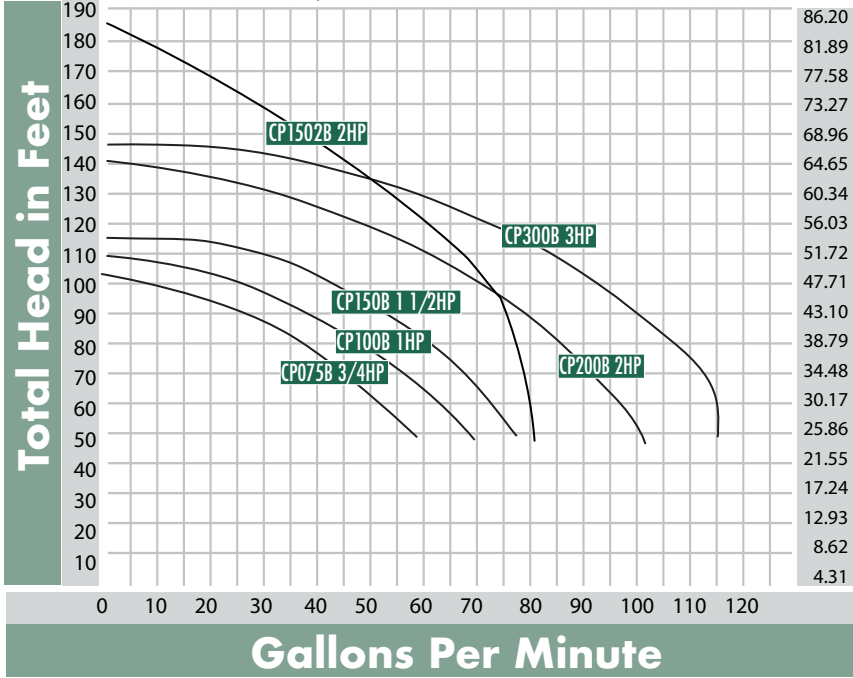

### Specifications

HP	Phase	Standard Voltage	Discharge	Suction	Dimensions			Control	Approx Ship Weight/Lbs	Model Number
					Height	Length	Depth			
3/4	1	208-230	1 1/2"	2"	24 1/2"	36"	19 1/2"	Pressure Start Control Box	109	CP075B220AYFT
1										CP100B220AYFT
1 1/2										CP150B220AYFT
2										CP200B220AYFT
2										CP1502B220AYFT
3										CP300B220AYFT

Available in 3 phase, must specify line voltage. Contact Munro for other control, phase or voltage options. Lead times vary for specialty or custom options.

All measurements are approximate and are subject to change. See our website for complete dimensions and specifications.

## Munro Complete PRO II – 5 hp



### A Better, COMPLETE Solution

With or without enclosure.

This rugged, complete pump system simplifies installation and can be customized for your application. The skid-only version is perfect for indoor installations, while the powder-coated marine grade aluminum enclosure will stand up to outdoor elements.

### ADVANTAGES

- **Easiest system to select & specify** – One professional package includes pump, smart controls and enclosure.
- **Highest quality components** – High quality materials for a clean, durable installation to be proud of.
- **Fast and easy installation** – Comes complete. No parts to forget, no need for shortcuts. No fuss, no errors.



### Did You Know?

Munro offers a variety of adapters to link a grooved coupling to your irrigation system. For steel pipe, groove x weld or groove x thread are great options. For PVC systems, grooved x spigot, groove x thread and other PVC adapters are available. See fitting and flange section on p.133.



### Companion Products!

- 4" PVC Basket Strainer to filter debris before pump (p.184)
- 4" Flange Butterfly Valves for troubleshooting and isolation (p.170)

SECURITY – Lockable

PUMP CONTROL – Choose from the full range of Munro pump controls, including StartBoxes, SmartBoxes, and BrainBoxes, housed in their own UL-50 Type 3R enclosures and including features such as thermal protection, safe 24v out and run-dry protection.

ENCLOSURE OR SKID – Powder-coated marine-grade aluminum offers durable housing or base to stand up to the elements. Made to order.

SELF COOLING – Vented for air flow to keep the pump cool.

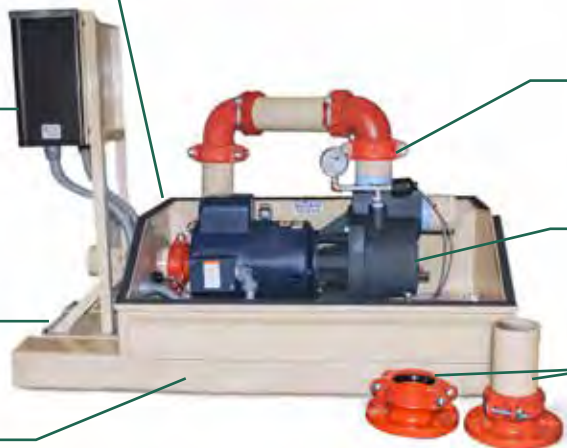

FITTINGS AND ACCESSORIES – From our rugged pipe and grooved couplings to the long-lasting electrical components included, the Munro Complete PRO II is complete with everything you need.

PUMP – Our LP Series 5 hp centrifugal pumps are durable and long lasting with industry-leading performance to horsepower.

FLANGED CONNECTION – Inlet and Outlet are flanged for easy system installation.

## Munro Complete PRO II – 5 hp

### Curves

HORSEPOWER RANGE: 5

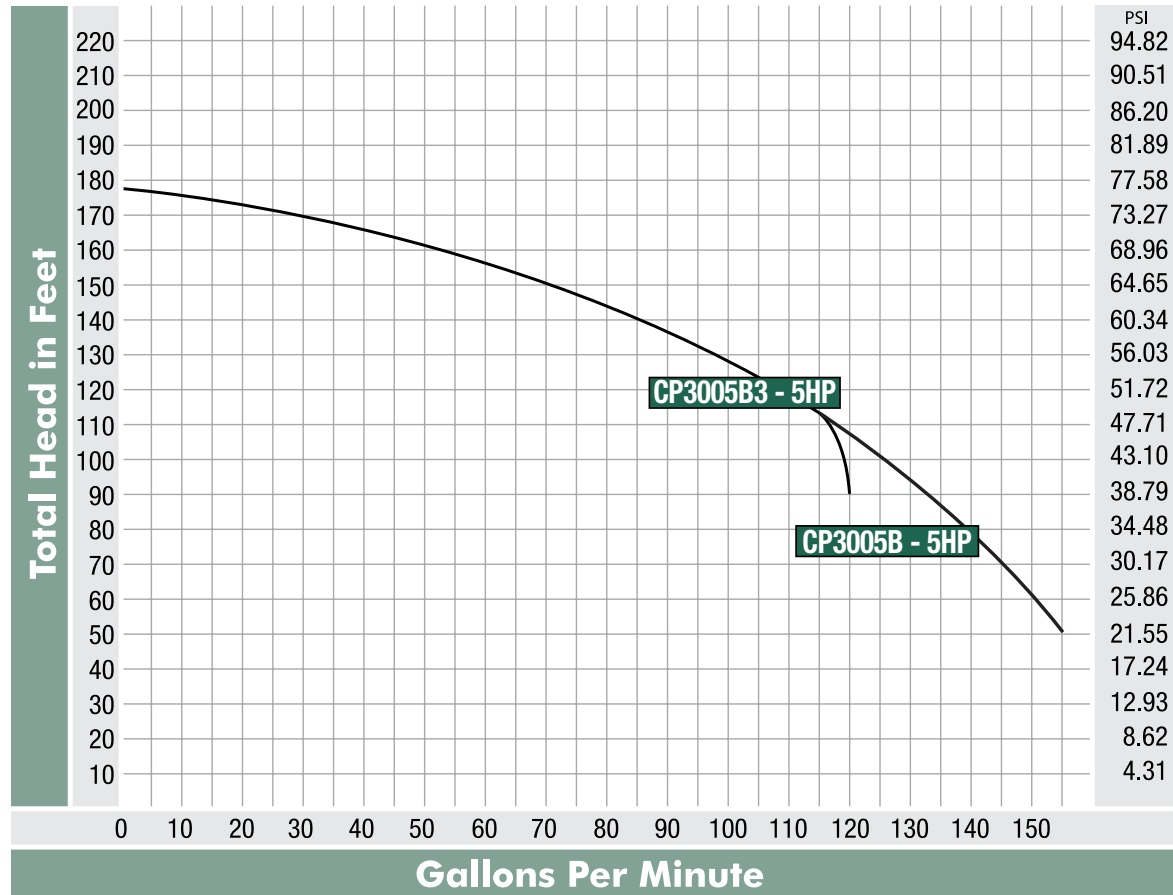

### Specifications

HP	Phase	Voltage**	Discharge	Suction	Dimensions			Enclosure	Skid Mounted	Approx. Shipping Weight lbs	Model Number*
					Height	Length	Depth				
5	1	208-230	3"	3"	35.5"	44"	22"	X	X	295	CP3005B
	3	208-230									CP3005B3
	1	208-230									CP3005B-SKID
	3	208-230									CP3005B3-SKID

\*Model numbers shown are for Complete PRO II – 5hp with standard SmartBox MPLC2452WTS. Contact Munro for other control or voltage options.

\*\* For 208V, contact factory for special accommodations.

All measurements are approximate and are subject to change, without notice.

# Munro Universal PRO Enclosure



Munro's Universal PRO Enclosure is designed specifically for a pump. The powder-coated stainless steel enclosure includes inlet and outlet ventilation points, mounting for a pump control box, and security features to keep your investment safe.

### ADVANTAGES

- **Easy** – Order the enclosure separately or include all the fittings you need. Assembly is simple with the hand-held rivet gun.
- **Professional** – With a Universal PRO Enclosure, your pump installation looks professional and is protected. This enclosure is built to last.
- **Better** – Durable, adaptable, and easy to assemble and use. With the Universal PRO Enclosure, you finally have a better way to house a pump, at a great price!



**Did You Know?**  
Side or bottom discharge option available.

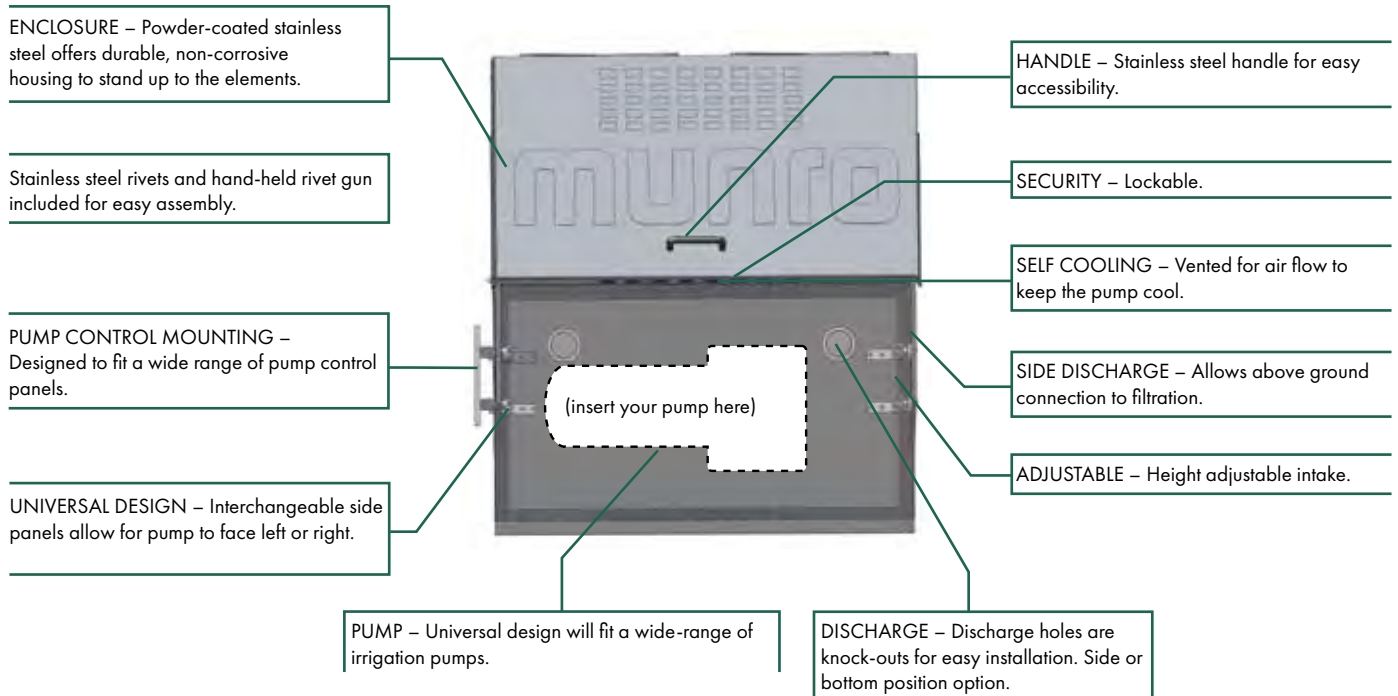
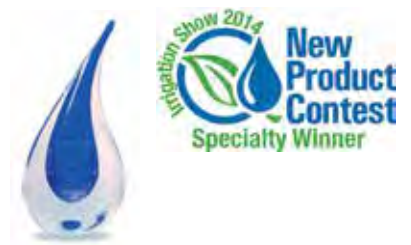

## Munro Universal PRO Enclosure

### Dimensions

CENTRIFUGAL

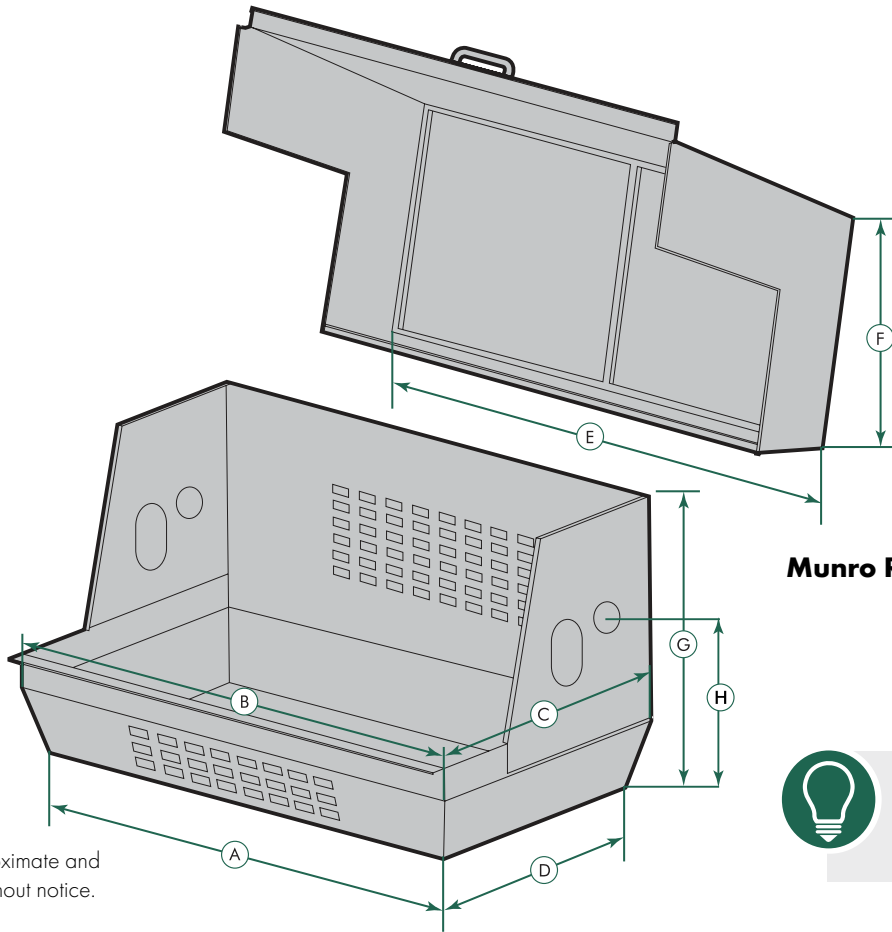

Suction and electrical panel adjustment height: 7 3/4" - 13 1/2"

Dimensions are approximate and subject to change without notice.

**Munro Rivet Gun Included!**



### Did You Know?

Centrifugal pumps need airflow to cool the motor for optimal longevity.

A	B	C	D	E	F	G	H	Approx Ship Weight lbs	Model Number
29 3/8"	31 1/2"	17 3/4"	15 3/4"	31 1/2"	13 3/4"	17 1/2"	10 1/2"	50	ENCP2



**Get everything you need!**

For other fitting options, see p.133-167.

### Optional Kits & Assemblies

(Order separately)

#### Pump Electrical Kit



See page 106

#### Centrifugal Pump Discharge Kit



See page 124

#### Centrifugal Pump Suction Assembly



See page 138

#### Centrifugal Pump Stand

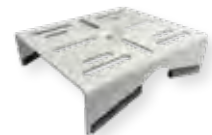

See page 186

## ABOUT SUBMERSIBLE PUMPS

### How does a submersible pump work?

A submersible pump is designed to run while located within the fluid being pumped. The fluid is accelerated by a spinning impeller to create pressure and move the liquid up through pipe or hose.

### Benefits and Applications

Submersible pumps run very efficiently, are virtually noiseless, and require minimal maintenance. Top discharge designed submersibles often cool the motor by flowing the fluid past the motor housing. This cooling process allows the pump to run long hours with little or no shutdown period. Submersibles with low discharge outlets are often designed for intermittent use. Submersible pumps have many uses including water features, water transfer, industrial settings, sump, effluent and sewage transfer.

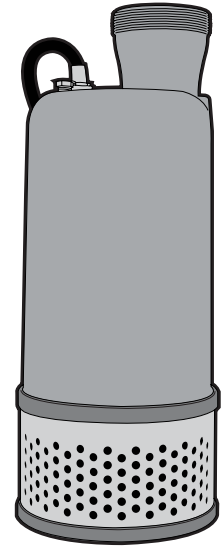

SUBMERSIBLE

## MUNRO PUMPS ARE EXCEPTIONAL

### Continuous duty design

We take continuous duty style submersibles a step further by using high-quality components such as abrasion-resistant double mechanical shaft seals and motors built for long life. Our designs keep the motor cool and your pump in service – day after day.

### A pump for every job

Whether you need to create a waterfall, pump out a basement, or move sewage – Munro’s got it! We have a full line of submersibles and can help you find the perfect pump for your job.

### Advanced engineering for efficiency and flexibility

We are pump experts who don’t settle for the same-old, same-old. We’ve improved standard industry designs to bring you products that are more efficient and versatile. Many of our submersibles draw lower amps than others on the market, which means they cost less to run. We use high quality components and thoughtful designs to give you more flexibility and versatility.



**Did You Know?**  
Use a Munro Liquid Level Pump Control to extend pump life and increase efficiency. See p.90 for details.

✓ = Acceptable for Application    –    ✓✓ = Recommended for Use

### Choosing the Right Pump for the Right Application

	RP	FS	POND	FSR	FSL	Bottom Suction	SUMP	FSA	FSA Survivor	FSG	FSE
Irrigation	✓	✓				✓✓					
Water Features	✓✓	✓✓	✓✓	✓✓	✓✓	✓✓					
Dewatering	✓	✓✓	✓✓	✓✓	✓✓						✓✓
Water Transfer	✓	✓✓	✓✓	✓✓	✓✓		✓				✓✓
Industrial	✓	✓✓	✓✓	✓✓	✓✓	✓		✓	✓		✓✓
Sump	✓	✓	✓	✓	✓✓		✓✓				✓✓
Effluent	✓	✓✓	✓✓	✓✓	✓✓		✓	✓✓	✓✓	✓✓	✓✓
Grey water	✓	✓✓	✓✓	✓✓	✓✓	✓	✓	✓✓	✓✓	✓✓	✓✓
Sewage								✓✓	✓✓	✓✓	
Marine	✓	✓		✓	✓			✓	✓	✓	✓✓
Trash		✓						✓✓	✓✓	✓✓	
Flood Control	✓	✓		✓							

# Choosing the Right Submersible Pump

SUBMERSIBLE

## Munro RP Series 1/2 – 5 hp Features semi-open impeller



P 26

**Recommended for:** river and waterfall style decorative water features, both interior and exterior

**Other uses:** water transfer, wastewater, flood irrigation

## Munro RP Amphibious Series 2 – 5 hp



P 28

**Recommended for:** river and flooded irrigation, water features

**Other uses:** water transfer, wastewater, booster

## Munro RP Large Volume 7 1/2 – 20 hp Features aluminum bronze impeller



P 33

**Recommended for:** river and waterfall style water features

**Other uses:** large volume water transfer, flood control, extraction of water, flood irrigation, tail water recycling

## Munro FS Series 1/3 – 30 hp Features high-chrome wear-resistant impeller



P 38

**Recommended for:** river and waterfall style decorative water features, both interior and exterior, dewatering water with some abrasives

**Other uses:** water transfer, wastewater, flood irrigation

## Munro POND Series 1/7 – 1/3 hp



P 35

**Recommended for:** water features, dewatering, utility, sump

**Other uses:** hot tub drainage, pools, pool covers, cooling water for machinery

## Munro FS R Series



P 44

**Recommended for:** dewatering to within 1/8" depth

**Other uses:** water features, water transfer

## Munro FS L Series 1/2 – 1 hp



P 46

**Recommended for:** pondless and waterfall style water features

**Other uses:** construction dewatering, utility, manholes

## Munro 5" Multistage Bottom Suction Submersible Pumps



P 65

**Recommended for:** irrigation, shallow wells, rain collection tanks, grey water

**Other uses:** dewatering, fountains, pressure boosting domestic non-potable water

## Munro SUMP Series 1/7 – 1/3 hp



P 51

**Recommended for:** sump, dewatering, utility

**Other uses:** hot tub drainage, pools, water features pool covers, cooling water for machinery

## Munro FS A Sewage Pumps 1/3 – 3/4 hp



P 58

**Recommended for:** sewage

**Other uses:** effluent

## Munro FS A Industrial Survivor Sewage Pumps 1 – 2 hp



P 60

**Recommended for:** commercial sewage

**Other uses:** residential sewage

## Munro FS G Sewage Grinder Pumps 2 hp



P 62

**Recommended for:** sewage

**Other uses:** effluent

## Munro FS E 1/3 – 3/4 hp Sump & Effluent Pumps



P 53,56

**Recommended for:** sump, effluent

**Other uses:** utility, dewatering

\* Unless otherwise noted Munro submersible pumps not intended for drinking water applications.

# SUBMERSIBLE WATER FEATURE PUMPS

## Submersible Water Feature Pumps

The pump is the most important aspect of any water feature. Whether you are creating melodic raindrops, a rushing river, or a dramatic spillway, selecting the right pump will provide the perfect water volume to make the project a success.

As with any construction project, a properly working water feature is dependent on high-quality components. Well-made long-lasting pumps, like Munro builds, will decrease annoying maintenance issues and cost less to run over the long term. Many features require continuous operation to maintain water turnover and minimize algae. Choosing a pump that is designed for long life operation is essential.

### Choosing a pump for a water feature

- 1. Style of feature** – There are many different types of water features, such as ponds, river/streams, falls, etc., and each require different features and capabilities.
- 2. Height of feature** – How high will you need to move the water from the water source to the discharge point?
- 3. Width of waterway and depth of water desired over any spillways** – Look for a pump that can create the desired volume of water – too much or too little can make a big difference in the feel of the feature. Many features are designed to provide pleasant ambient sound which can require a higher-volume pump.
- 4. Turnover rate** – Cycling the water through a filter will keep it cleaner and healthier. Choose a pump with a gallons per hour (gph) rate high enough to cycle the total volume of your water feature through quickly enough to meet your desired turnover rate. For example, a 1,000 gallon water feature may need a pump that can cycle through at least 500 gph to ensure the total volume is turned over once every two hours, 12 times per 24 hours.
- 5. Fish in the water feature** – You'll want to ensure that the pump is safe for the fish. You may also want to consider a higher turnover rate to keep the feature clean.

### Curves

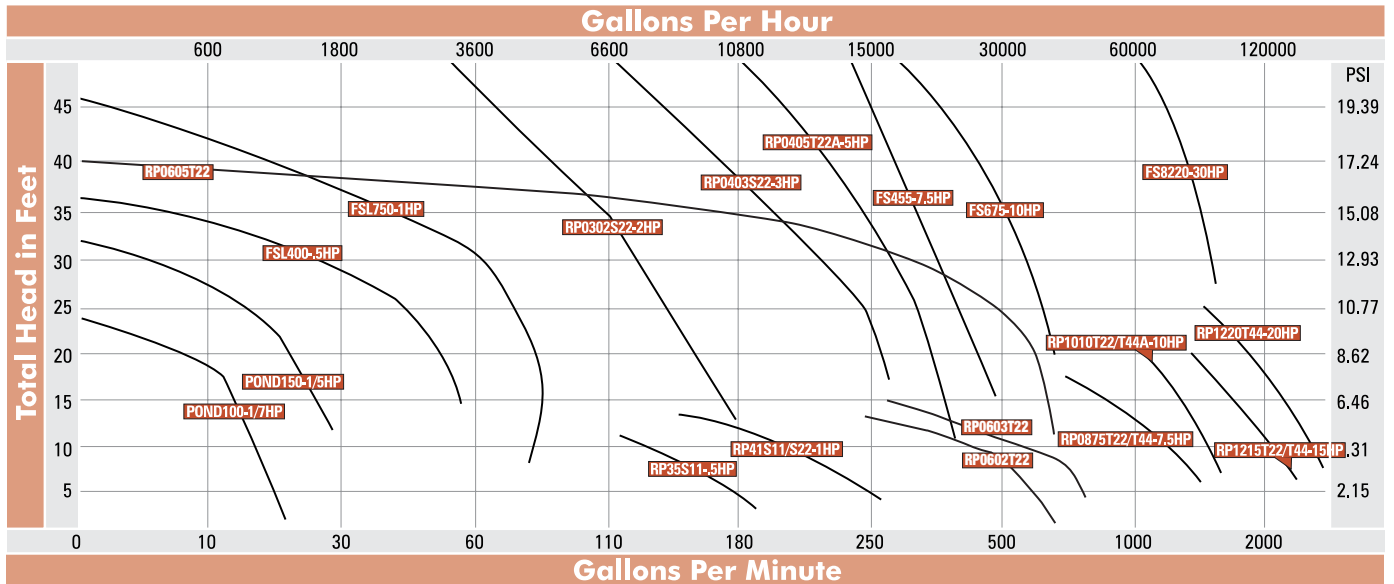

### Water Feature GPM Estimate Per 1' Weir Width

Flow Depth (inches)	Discharge Rate per foot of Weir Width	Flow Depth (inches)	Discharge Rate per foot of Weir Width	Flow Depth (inches)	Discharge Rate per foot of Weir Width
1/2	13	3	187	6	528
3/4	24	3 1/2	236	6 1/2	596
1	36	4	287	7	605
1 1/2	66	4 1/2	343	7 1/2	738
2	102	5	402	8	814
2 1/2	142	5 1/2	463	8 1/2	890

## Munro RP Series – 2-5 hp

SUBMERSIBLE



Designed for continuous duty water features, the Munro RP Series pumps offer high flow to horsepower ratios with low amp draw for a lower operating cost. The RP Series pumps work vertically or horizontally for maximum flexibility. The option to mount the pump horizontally can provide special advantages in concealing the pump within complex decorative water features.

- **Abrasion-resistant mechanical shaft seal** – protects the motor for longer life
- **Enclosed channel impeller** – increases efficiency and lowers operating cost
- **Stainless steel outer case** – durable and low maintenance

### COMMON APPLICATIONS

Recommended for: river and waterfall style decorative water features, both interior and exterior

Other uses: non-potable water transfer, wastewater, flood irrigation

### ADVANTAGES

**Continuous duty design** – These pumps are made to run! Our design takes the flow path across the motor housing to whisk away the heat generated by the motor. A cool motor means a longer life.

**Low cost to own** – When pumps are in continuous use, the energy use and cost can really add up! Our pumps use lower amps than our competitors, which saves power and money.

**Industry leading performance to horsepower** – High gallon output sets this pump apart from the crowd.

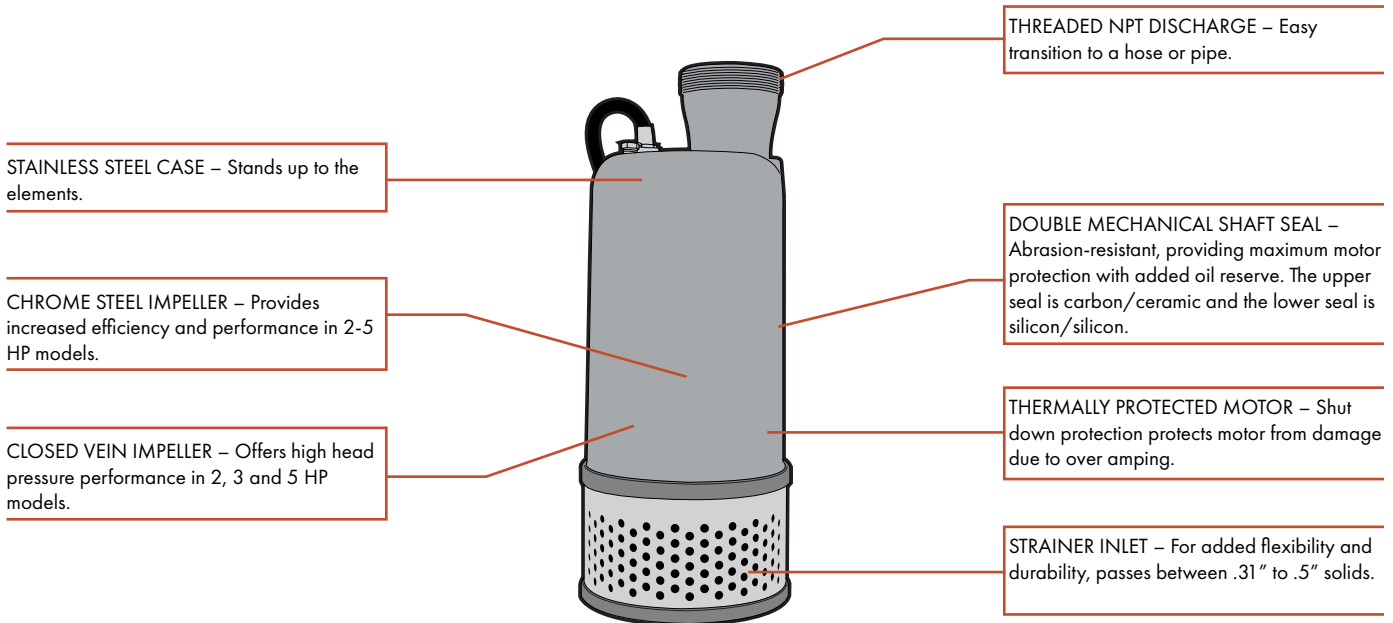

### Did You Know?

Submersible pumps used to feed centrifugal pumps need to exceed the centrifugal pump GPM output.

# Munro RP Series – 2-5 hp

## Curves

HORSEPOWER RANGE: 1/2 – 1 (Mix Flow Impeller\*)

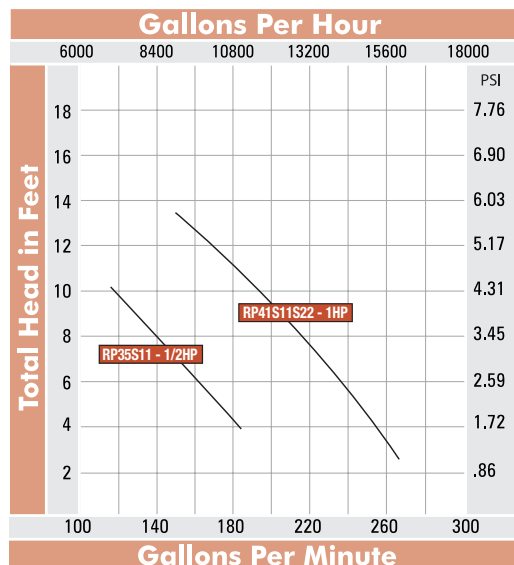

**Did You Know?**  
To reduce friction loss, installing pumps with a mixed flow impeller – like the RP35 and RP41 – discharge pipe should be equal to or greater size than the pump outlet.

## Curves

HORSEPOWER RANGE: 2 – 5 (Standard Impeller)

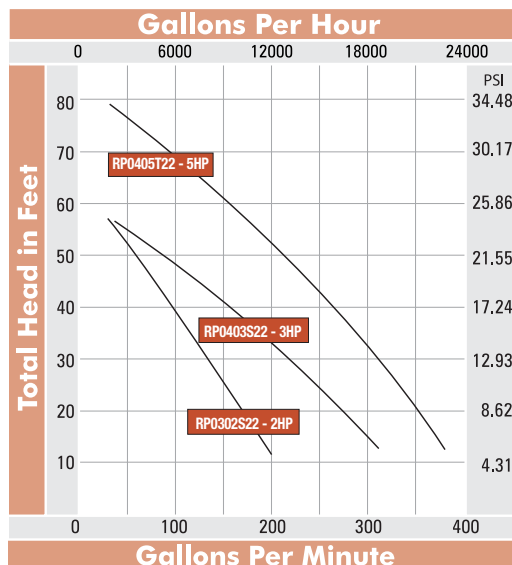

\* Mixed flow impeller – see Did You Know? on p.34

## Pick-A-Pump

TOTAL HEAD IN FEET	GALLONS PER HOUR						PSI
	600	9000	12000	15000	18000		
70							30.17
60	RP0405	RP0405					25.86
50	RP0403	RP0403	RP0405				21.55
40	RP0403	RP0403	RP0405	RP0405			17.24
30	RP0302	RP0403	RP0403	RP0405	RP0405		12.93
20	RP0302	RP0302	RP0403	RP0403	RP0405		8.62
10		RP41					4.31
5		RP35	RP41	RP41			2.15
	100	150	200	250	300		
	GALLONS PER MINUTE						

## Specifications – Pump

HP	Phase	Max Head ft	Max Capacity gpm	Max Capacity gph	Discharge in	Weight lbs	Solid Pass in	Dimension		Model Number
								dia	hgt	
1/2	1	10	185	11,100	3	55	.5	8.75"	19"	RP35S11
1	1	13	278	16,680	4	57	.5	8.75"	19"	RP41S11
1	1	13	278	16,680	4	57	.5	8.75"	19"	RP41S22
2	1	60	190	11,400	3	95	.31	9.37"	21"	RP0302S22
3	1	63	305	18,300	4	103	.43	9.37"	21"	RP0403S22
5	3	84	375	22,500	4	103	.43	9.37"	21"	RP0405T22

## Specifications – Motor

Power		Amps	Phase	Start Method	Cord Length	Thermal Protection	Liquid Max Temp.	Model Number
HP	Volts							
1/2	110	8.4	1	Direct	30'	Y	104° F	RP35S11*
1	110	10.4	1	Direct	30'	Y		RP41S11*
1	208-230	6.5-5.2	1	Direct	30'	Y		RP41S22*
2	208-230	11.25-9.0	1	Cap	24'	Y		RP0302S22
3	208-230	16.75-13.4	1	Cap	24'	Y		RP0403S22
5	208-230	16-12.8	3	Direct	24'	Y		RP0405T22

SUBMERSIBLE

## Munro RP Series – 2 - 5 hp Amphibious

SUBMERSIBLE



This amphibious pump designed for continuous duty water features does not need a vault. The pump can be positioned at the bank instead of the bottom of a non-potable water source because a hose and strainer allows remote intake of fluid. RP amphibious pumps can also be piped pump to pump to double the pressure!

- **Abrasion-resistant mechanical shaft seal** – protects the motor for longer life
- **Enclosed channel impeller** – increases efficiency and lowers operating cost
- **Stainless steel outer case** – durable and low maintenance

### COMMON APPLICATIONS

Recommended for: river and flooded irrigation

Other uses: water transfer, wastewater

### ADVANTAGES

**Easy to place and maintain** – The amphibious design means you can retire your waders! Place this pump right on the bank of the water, where it's easy to maintain. Laying down or standing up, you'll see the same great performance.

**Higher than average flow to hp with pump-to-pump pressure boost capability** – High gallon output sets this pump apart from the crowd. If you need an extra boost, plumb pump-to-pump and double your output pressure.

**Low cost to own** – When pumps are in continuous use, the energy use and cost can really add up! Our pumps use lower amps per gallon pumped than most of our competitors, which saves power and money.

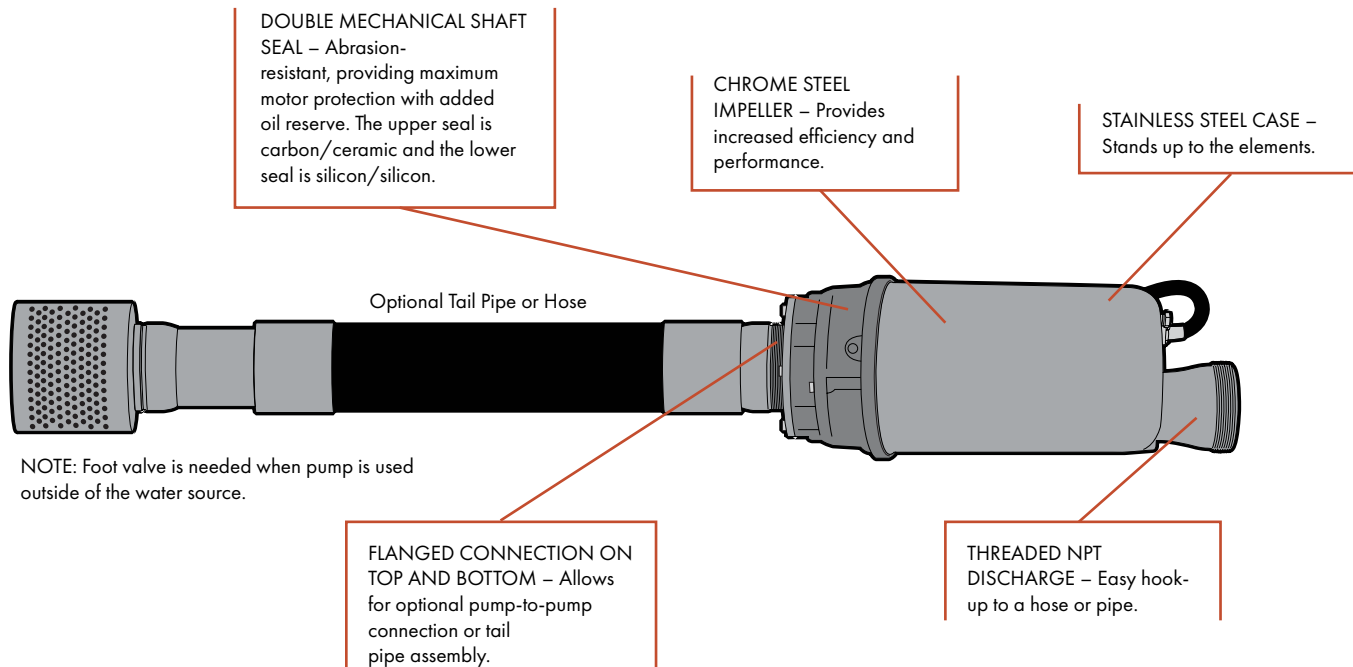

**Get everything you need!**

Hose assemblies can be found on pages 122–129.

# Munro RP Series – 2 - 5 hp Amphibious

## Curves

HORSEPOWER RANGE: 2 – 5

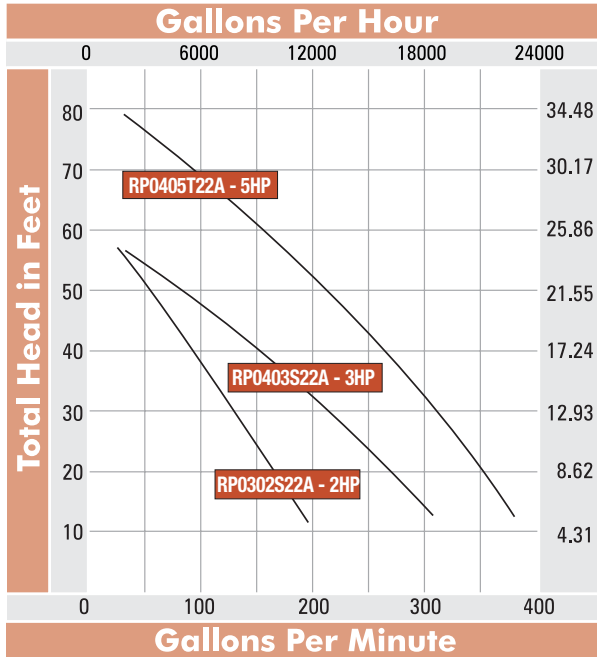

SUBMERSIBLE

## Pick-A-Pump

TOTAL HEAD IN FEET	GALLONS PER HOUR			PSI
	600	12000	18000	
70	RP0405			30.17
60	RP0405			25.86
50	RP0403	RP0405		21.55
40	RP0403	RP0405		17.24
30	RP0302	RP0403	RP0405	12.93
20	RP0302	RP0403	RP0405	8.62
10				4.31
	GALLONS PER MINUTE			
	100	200	300	

## Specifications – Pump

HP	Phase	Max Head ft	Max Capacity gpm	Max Capacity gph	Discharge in	Weight lbs	Solid Pass	Dimension		Model Number
								dia	hgt	
2	1	60	190	11,400	3	95	0.31	9.37"	18"	RP0302S22A
3	1	63	305	18,300	4	103	0.43	9.37"	18"	RP0403S22A
5	3	84	375	22,500	4	103	0.43	9.37"	18"	RP0405T22A

## Specifications – Motor

Power		Amps	Phase	Start Method	Cord Length	Thermal Protection	Liquid Max Temp.	Model Number
HP	Volts							
2	208-230	11.25-9.0	1	Cap	24'			RP0302S22A
3	208-230	16.75-13.4	1	Cap	24'	Y	104° F	RP0403S22A
5	208-230	16-12.8	3	Direct	24'			RP0405T22A

## Munro RP Series – 2 - 5 hp



SUBMERSIBLE

Designed for continuous duty water features, the Munro RP Series pumps offer high flow to horsepower ratios with low amp draw for a lower operating cost. The RP Series pumps work vertically or horizontally for maximum flexibility. The option to mount the pump horizontally can provide special advantages in concealing the pump within complex decorative water features.

- **Abrasion-resistant mechanical shaft seal** – protects the motor for longer life
- **Enclosed channel impeller** – increases efficiency and lowers operating cost
- **Stainless steel outer case** – durable and low maintenance

### COMMON APPLICATIONS

Recommended for: river and waterfall style decorative water features, both interior and exterior  
Other uses: non-potable water transfer, wastewater, flood irrigation

### ADVANTAGES

**Continuous duty design** – These pumps are made to run! Our design takes the flow path across the motor housing to whisk away the heat generated by the motor. A cool motor means a longer life.

**Low cost to own** – When pumps are in continuous use, the energy use and cost can really add up! Our pumps use lower amps than our competitors, which save power and money.

**Industry leading performance to horsepower** – High gallon output sets this pump apart from the crowd.

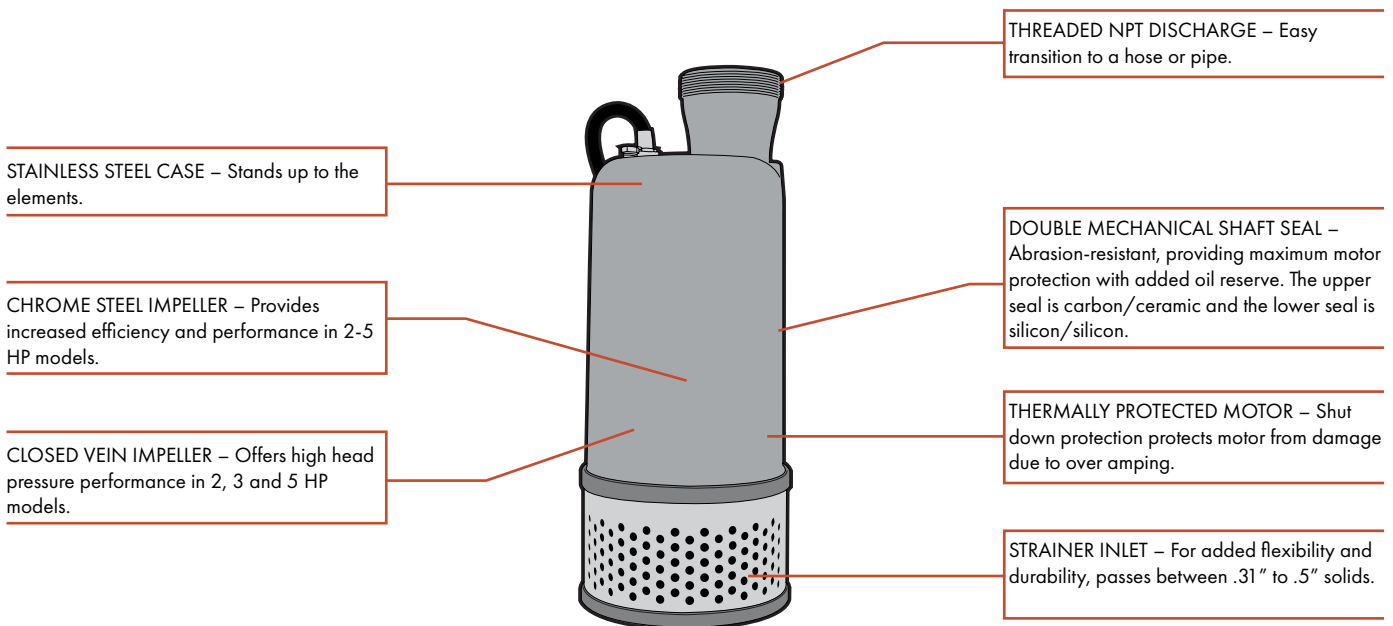

# Munro RP Series – 2 - 5 hp

## Curves

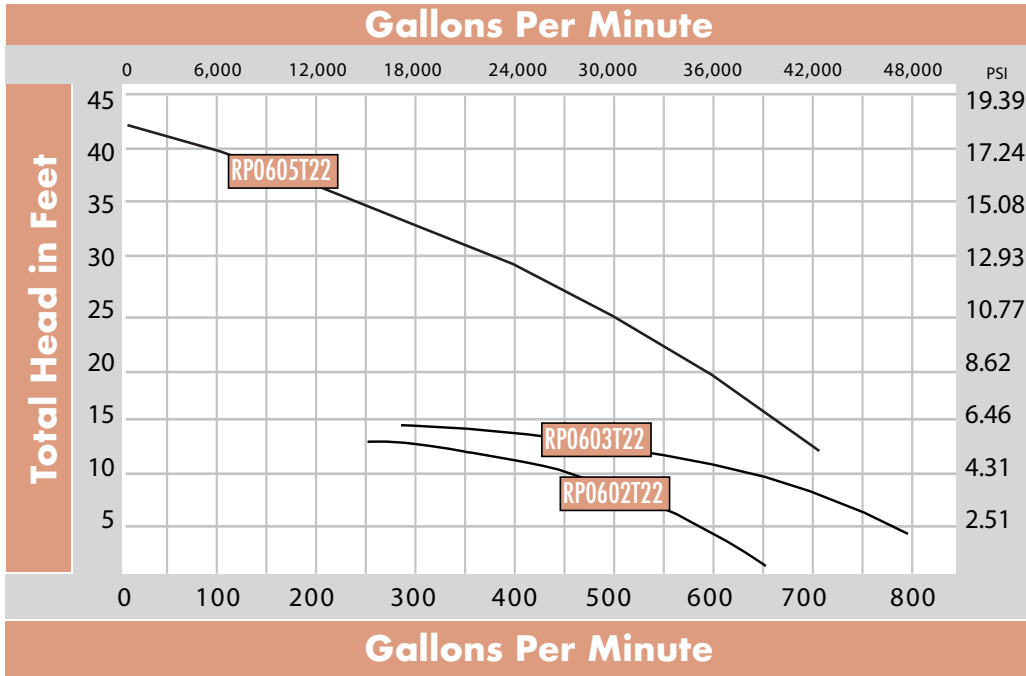

SUBMERSIBLE

## Specifications – Pump

HP	Phase	Max Head ft	Max Capacity gpm	Max Capacity gph	Discharge in	Weight lbs	Solid Pass in	Dimension		Model Number
								dia	hgt	
2	3	13	660	39,600	6	112	3/4	11.25"	23.5"	RP0602T22
3	3	16	845	50,700	6	115	3/4	11.25"	23.5"	RP0603T22
5	3	39	820	49,200	6	157	3/4	11.25"	26.125"	RP0605T22

## Specifications – Motor

Power		Amps	Phase	Discharge	Cord Length	Max Flow	Solids Passage	Model Number
HP	Volts							
2	230V	6.4	3	6"	13'	660 gpm	3/4"	RP0602T22
3	230V	8.9	3	6"	16'	845 gpm	3/4"	RP0603T22
5	230V	14.6	3	6"	39'	820 gpm	3/4"	RP0605T22

## Munro RP Pumps – Amphibious Uses

### Flood Irrigation

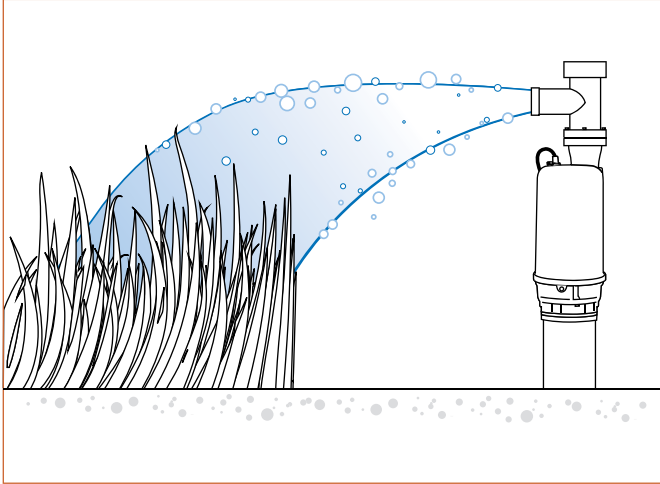

### Ditch with Water Level too Low for Centrifugal Pump Alone

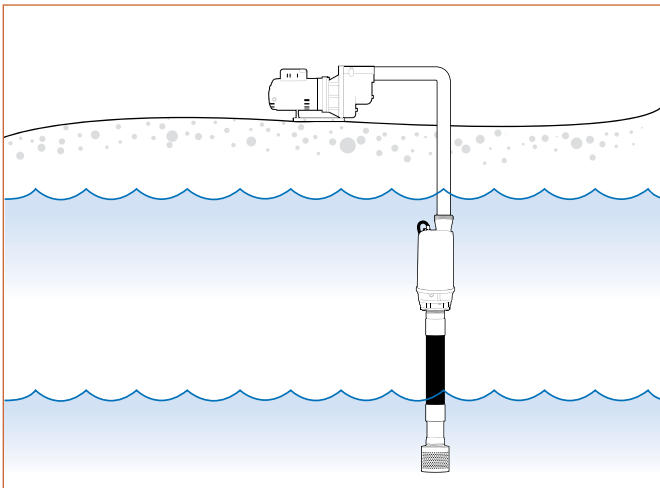

### Multi-Pump Boost

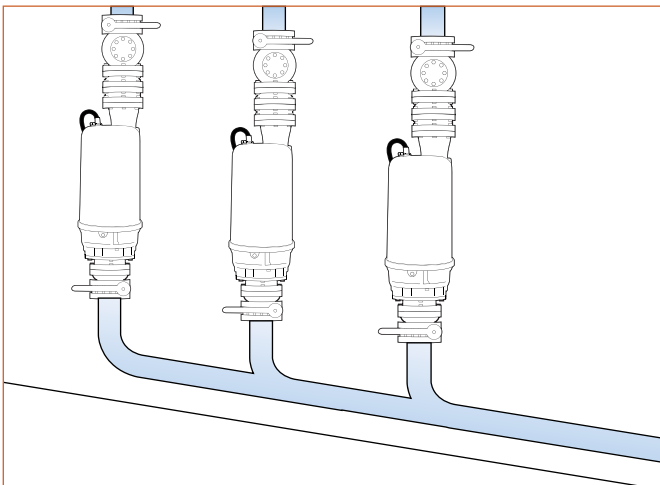

### Applications:

Fully submerged – horizontal or vertical

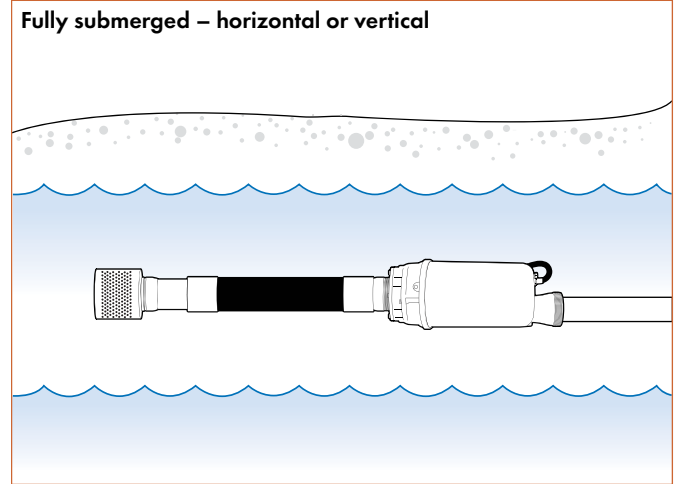

Partially submerged with foot valve

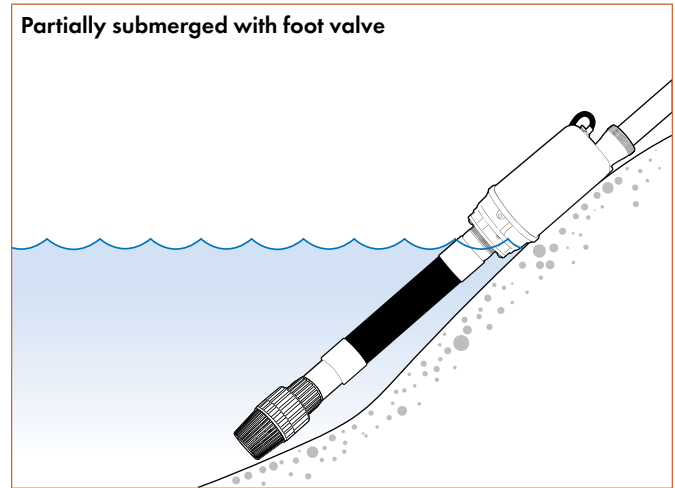

### Tail Pipe



Hose with Strainer  
Various lengths and configurations  
available.

For Hose and Strainer options, see  
pages 122–127, and 183,184.



### Did You Know?

Remote suction keeps the pump at the bank while pulling water from deeper area of pond.

## Munro RP 7 1/2 - 20 hp



You can create a river with these pumps! For extremely high gpm capacity with virtually zero noise, the RP Large Volume series has a mixed flow impeller design, achieving high water flow and low head.

- **Abrasion-resistant mechanical shaft seal** – protects the motor for longer life
- **Impeller flow guide vane** – increases efficiency and lowers operating cost
- **Stainless steel outer case** – durable and low maintenance

### COMMON APPLICATIONS

Recommended for: river and waterfall style water features  
Other uses: large volume non-potable water transfer, flood control, area dewatering, extraction of water, flood irrigation, tail water recycling

### ADVANTAGES

**Much higher than average flow to horsepower** – Using an axial and mixed flow design, the RP large volume pumps live up to their billing. The proof is in our curves – you’ll see maximum flow at low head levels.

**Continuous duty design** – These pumps are made to run! Our design takes the flow path across the motor housing to whisk away the heat generated by the motor. A cool motor means a longer life.

**Low cost to operate** – These pumps are at their most efficient at full flow. Other pumps can not make that claim!

**MECHANICAL GROOVE DISCHARGE FITTING** – Allows various types of discharge attachments to fit specific application, including flanged, hose barb, or threaded.

**LIFTING RING AND CABLE** – For safe and easy lifting with forklift.

**STAINLESS STEEL CASE** – Stands up to the elements.

**DOUBLE MECHANICAL SHAFT SEAL** – Abrasion-resistant, providing maximum motor protection with added oil reserve. The upper seal is carbon/ceramic and the lower seal is silicon/silicon.

**ALUMINUM BRONZE MIXED-FLOW IMPELLER** – Maximizes flow rates with little noise or vibration.

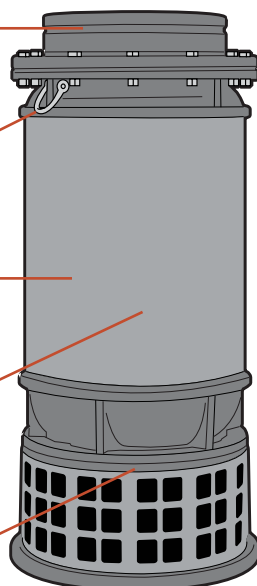

### Optional Discharge & Fittings

#### Threaded



Size	Model No.
8"	SH59X8X6
10"	SH59X10X6
12"	SH59X12X6

#### Flanged



Size	Model No.
8"	SH7041X8
10"	SH7041X10
12"	SH7041X12

#### Hose Barb



Size	Model No.
8"	AP3TCNV0800
10"	AP3TCNV1000
12"	AP3TCNV1200

#### Coupling



Size	Model No.
8"	M7705X8
10"	M7705X10
12"	M7705X12

(Order separately)



**Get everything you need!**

Other grooved fittings available on pages 152-163, 167.

## Munro RP – 7 1/2 - 20 hp

### Curves

HORSEPOWER RANGE: 7 1/2 – 20

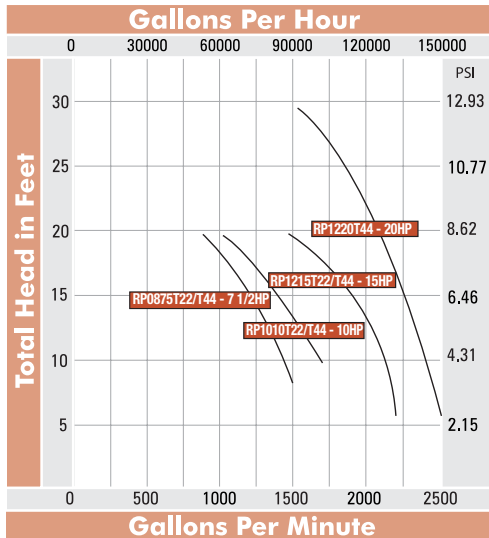

**Get everything you need!**  
See page 127-129 for Discharge Hose assemblies.



**Did You Know?**  
Mixed flow impellers act like a propeller and are more energy efficient at high flows/low head.

### Pick-A-Pump

TOTAL HEAD IN FEET	GALLONS PER HOUR						PSI
	45000	60000	75000	90000	105000	120000	
25				RP1220			10.78
20				RP1220	RP1220	RP1220	8.62
15			RP1010	RP1215	RP1215	RP1220	6.47
10		RP0875	RP1010	RP1010	RP1215	RP1215	4.31
	750	1000	1250	1500	1750	2000	
	GALLONS PER MINUTE						

### Specifications – Pump

HP	Phase	Max Head ft	Max Capacity gpm	Max Capacity gph	Discharge in	Weight lbs	Solid Pass	Dimension		Model Number
								dia	hgt	
7.5	3	19	1,500	90,000	8	268	0.87	13.39"	33"	RP0875T22
	3	19	1,500	90,000	8	268	0.87	13.39"	33"	RP0875T44
10	3	19	1,650	99,000	10	361	0.87	14.96"	35.5"	RP1010T22
	3	19	1,650	99,000	10	361	0.87	14.96"	35.5"	RP1010T44
15	3	20	2,200	132,000	12	460	0.90	16.93"	40"	RP1215T22
	3	20	2,200	132,000	12	460	0.90	16.93"	40"	RP1215T44
20	3	25	2,500	150,000	12	485	0.90	16.93"	41"	RP1220T44

### Specifications – Motor

Power		Amps	Phase	Start Method	Cord Length	Thermal Protection	Liquid Max Temp	Model Number
HP	Volts							
7.5	208-230	26-21.0	3	Direct	24'	N	104° F	RP0875T22
	460	10.5						RP0875T44
10	208-230	33-26.8						RP1010T22
	460	13.4						RP1010T44
15	208-230	46-37.4						RP1215T22
	460	18.7						RP1215T44
20	460	23.7	RP1220T44					

## Munro POND Series – 1/7 - 1/5 hp



Designed for continuous or intermittent duty, the Munro POND Series pumps offer an excellent value and Munro's high-quality standards. This space-saving, yet heavy-duty pump is low-water friendly and long lasting.

- **Abrasion-resistant mechanical shaft seal** – protects the motor for longer life
- **Self-protecting motor** – at high heat, automatic shutdown when there is no more fluid to pump
- **AAS plastic outer case** – durable and non-corrosive

### COMMON APPLICATIONS

Recommended for: water features, dewatering, utility, sump  
Other uses: hot tub drainage, pools, pool covers, cooling water for machinery

### ADVANTAGES

**Low failure rate** – This pump has a failure rate well under 1% because the same build principles of superior design used in Munro's larger pumps are used in the POND pump. A mechanical shaft seal protects this super-efficient motor.

**True continuous duty design** – These pumps are made to run! Our design takes the flow path across the motor housing to whisk away the heat generated by the motor. A cool motor means a longer life.

**Low cost to own** – Our pumps use lower amps and provide higher flows than our competitors, which saves power and money.

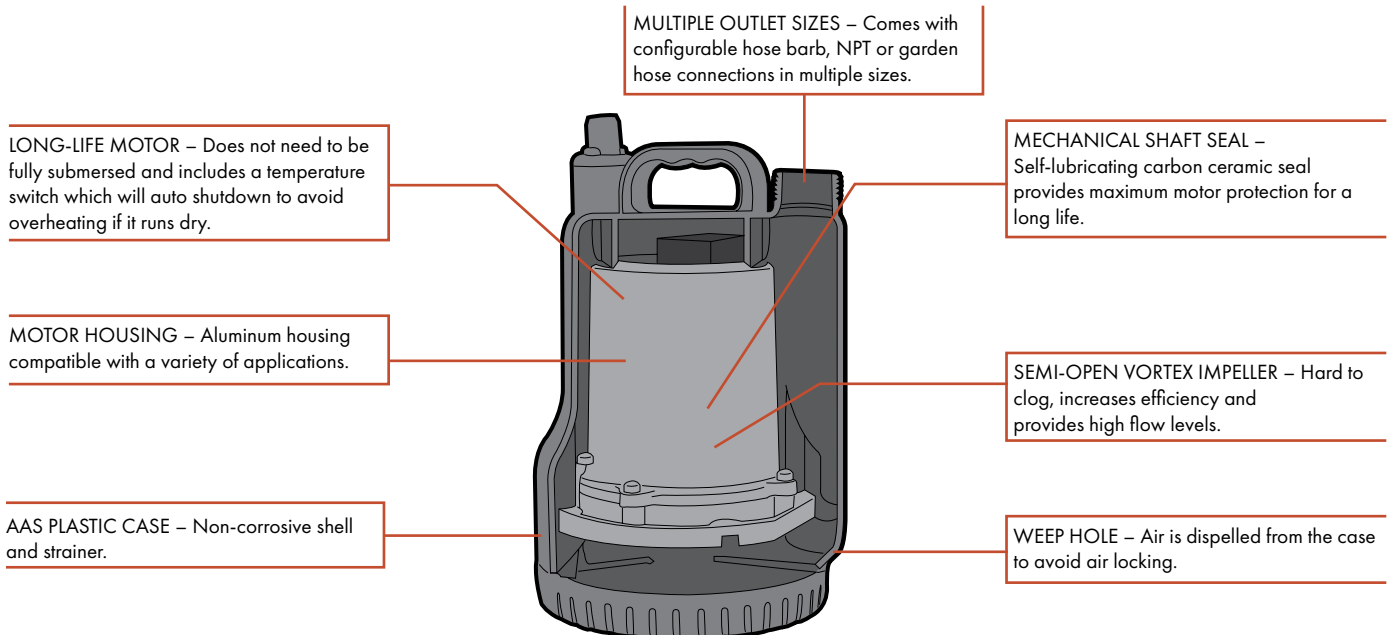

## Munro Pond Series – 1/7 - 1/5 hp

### Curves

HORSEPOWER RANGE: 1/7 - 1/3

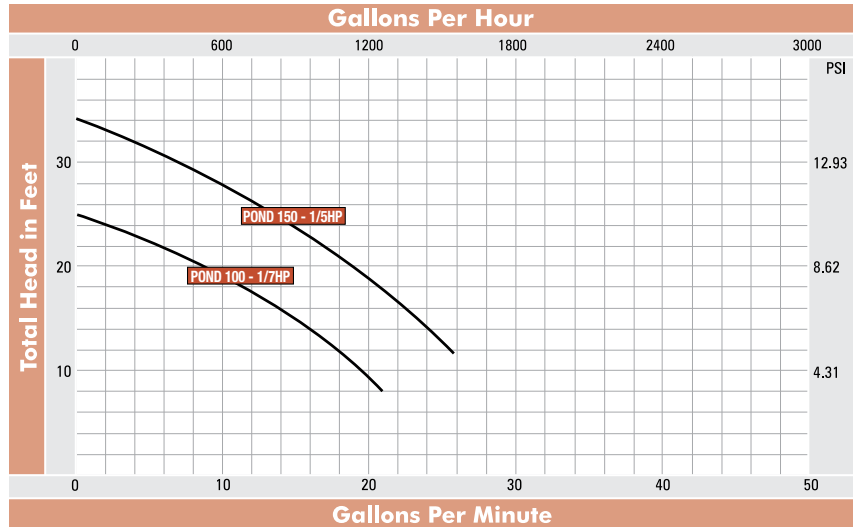

### Dimensions

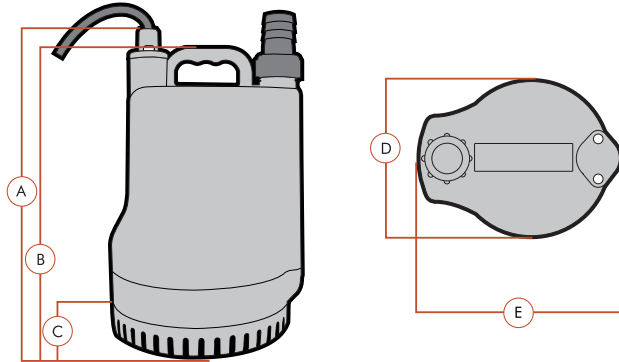

A	B	C	D	Model Number
10"	9.5"	2"	6"	POND100/150

### Specifications – Pump

HP	Discharge Options in	Max Head ft	Max Capacity gpm	Max Capacity gph	Weight lbs	Solid Passage in	Model Number
1/7	5/8, 3/4, 1" Hose, 5/8" GHT, 1" NPT	25	21	1,260	9	.25	POND100
1/5		34	28	1,680	10	.25	POND150

### Specifications – Motor

HP	Volts	Phase	Amps	Thermal Protection	Cord Length ft	Liquid Max Temp.	Model Number
1/7	110	1	2	Y	10	104° F	POND100
1/5	110		3				POND150

# SUBMERSIBLE DEWATERING PUMPS

## Submersible Dewatering Pumps

A dewatering pump is an invaluable tool for removing water quickly – whether in a commercial construction application or in a small residential clean-up job. These pumps are available in many different sizes and can range from small portable units to large stationary machines. Choosing the right pump for the job will save time, money and hassle.

### Choosing the right dewatering pump

#### 1. Determine the scope of your project

- Gallons per minute (GPM) – how much water do you need to move and how quickly do you need to move it?
- Head in feet – how high does the pump need to push the water, from the water level to where the water should emerge?
- Friction Loss – how long is the discharge pipe or hose, what friction losses must be considered?

#### 2. Determine the frequency of use and portability that you require

Will the pump be used continuously, periodically, or only once or twice? Do you need a pump that can be moved from one job site to another or will the pump be placed at one site for ongoing use?

#### 3. Consider the water

Is it clean or does it include small solids or debris that need to be pumped through?



Need performance greater than 100 feet or 500 GPM? See curves for performance up to 1350 GPM.

SUBMERSIBLE



#### Did You Know?

Munro builds dewatering pump stations for everything from wastewater sites to coal mines. We are experts in pumps – everything from small residential to huge commercial or industrial applications!

## Munro FS Series – 1/3 - 30 hp

SUBMERSIBLE



These extremely durable, long lasting pumps are perfect for countless applications. With our wide array of horsepower ranges, the FS series pumps are durable enough to take on mining and construction dewatering, and are also excellent for irrigation, industrial, and even non-potable residential applications like water features.

- **Abrasion-resistant mechanical shaft seal** – protects the motor for longer life
- **Premium impeller construction** – high chrome steel impeller is extremely hard and wear resistant in our 2 hp and above, while a ductile Iron impeller easily handles 1/3 to 1 1/2 hp flow conditions
- **Stainless steel case, shaft and strainer** – durable and low maintenance

### COMMON APPLICATIONS

Recommended for: dewatering, water transfer  
Other uses: water features

### ADVANTAGES

**Continuous duty design** – These pumps are made to run! Our double casing design takes the flow path across the motor housing to whisk away the heat generated by the motor. A cool motor means a longer life.

**Wear resistant materials** – We use stainless steel in our housing, shaft and strainer, providing wear resistance and a long life in all conditions.

**Great performance at a great value** – With our heavy duty construction, high head or high gpm capacity, and versatile design, you'll be pleasantly surprised when you compare this pump to its competition!

SEALED CABLE ENTRY – Allows for full submersion.

LIFTING RING AND CABLE – For safe and easy lifting with forklift.

STAINLESS STEEL SHAFT – Heat treated and highly wear resistant.

PREMIUM CONSTRUCTION IMPELLERS 2 hp and larger use an extremely durable and abrasion resistant high chrome steel impeller, while the 1/3 to 1 1/2 hp pumps are dynamically balanced with a smooth running ductile iron impeller.

THERMALLY PROTECTED MOTOR – Shut down protection protects motor from damage due to over amping.

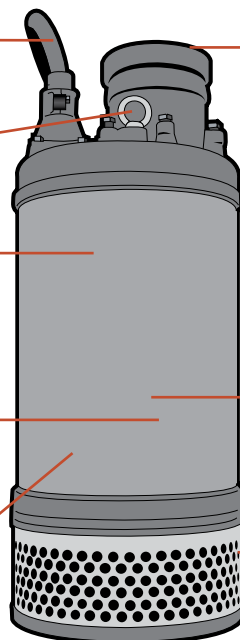

THREADED NPT DISCHARGE – Easy hook-up to, hose, pipe or grooved fittings.

STAINLESS STEEL DOUBLE CASING – Water flows past the motor to reduce heat.

DOUBLE MECHANICAL SHAFT SEAL – Abrasion resistant, providing superior wear resistance and minimal maintenance. The upper seal is carbon/ceramic and the lower seal is silicon/carbide.

STAINLESS STEEL STRAINER – For added longevity and durability.

# Munro FS Series – 1/3 - 30 hp

## Curves

HORSEPOWER RANGE: 1/3 - 1

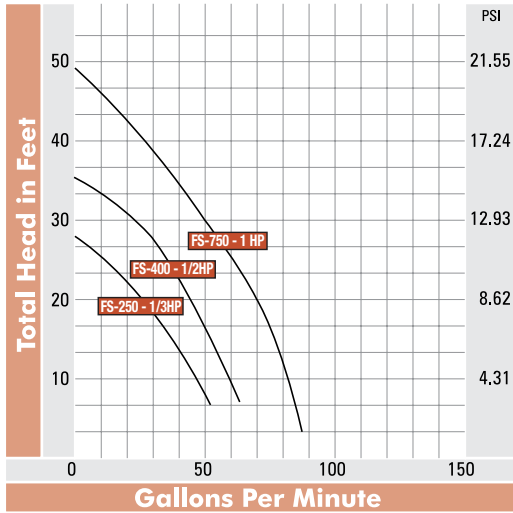

HORSEPOWER RANGE: 5 - 7 1/2

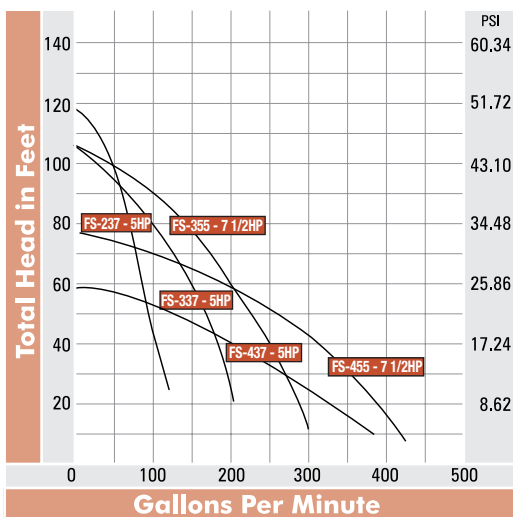

HORSEPOWER RANGE: 2 - 3

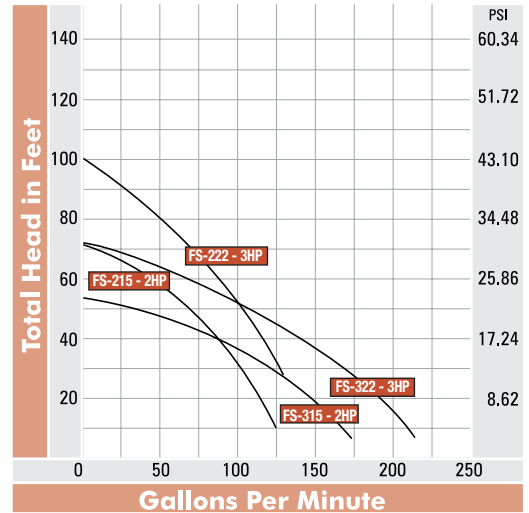

HORSEPOWER RANGE: 10 - 15

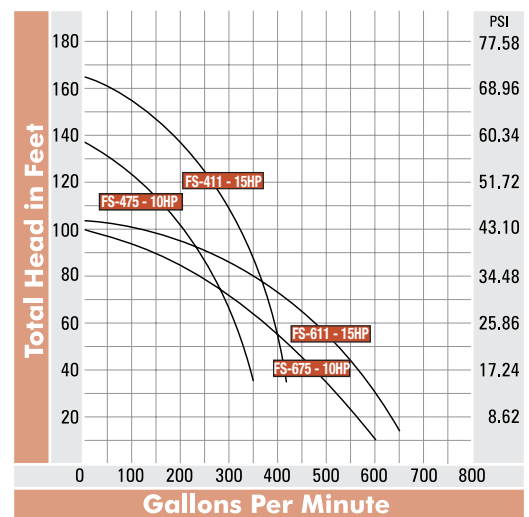

HORSEPOWER RANGE: 20 - 30

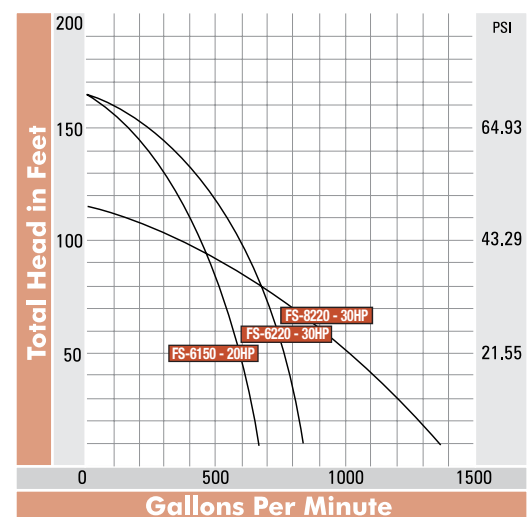

**Get everything you need!**  
Protect your investments with Munro Controls,  
see pages 77-106.

SUBMERSIBLE

## Munro FS Series – 1/3 - 30 hp

### Pick-A-Pump

SUBMERSIBLE

CHOOSING A MUNRO FS PUMP: FS250/400/750 HP RANGE: 1/3 - 1									
TOTAL HEAD IN FEET	40	FS750	FS750				17.24	PSI	
	30	FS400	FS750	FS750	FS750	FS750	12.93		
	20	FS250	FS400	FS400	FS750	FS750	FS750		8.62
	10		FS250	FS250	FS400	FS400	FS750		4.31
		20	30	40	50	60	70		
GALLONS PER MINUTE									

CHOOSING A MUNRO FS PUMP: FS215/315/222/322 HP RANGE: 2 - 3								
TOTAL HEAD IN FEET	80	FS222	FS222				34.48	PSI
	70	FS222	FS222		FS237		30.17	
	60	FS215	FS322	FS222/FS322	FS237		25.86	
	50	FS315	FS215	FS322	FS222/FS322	FS237	21.55	
	40	FS315	FS315	FS215/FS315	FS322	FS322	17.24	
	30		FS315	FS215/FS315	FS215/315	FS322	FS322	
20					FS315	FS322	8.62	
	25	50	75	100	125	150		
GALLONS PER MINUTE								

CHOOSING A MUNRO FS PUMP: FS237/337/437/355/455 HP RANGE: 5 - 7 1/2										
TOTAL HEAD IN FEET	90	FS237	FS355				38.79	PSI		
	80	FS237/FS337	FS337	FS355			34.48			
	70	FS455	FS237	FS355	FS355		30.17			
	60	FS455	FS455	FS455	FS355		25.86			
	50	FS437	FS437	FS337	FS455	FS455	21.55			
	40		FS437	FS437	FS437	FS455	FS455		17.24	
	30				FS437	FS437	FS455		FS455	12.93
	20						FS437		8.62	
	10								4.31	
		50	100	150	200	250	300		350	
GALLONS PER MINUTE										

CHOOSING A MUNRO FS PUMP: FS411/475/611/675 HP RANGE: 10 - 15								
TOTAL HEAD IN FEET	150	FS411					64.65	PSI
	140	FS411					60.34	
	130	FS411	FS411				56.03	
	120	FS475	FS411				51.72	
	110	FS475	FS411	FS411			47.41	
	100	FS611	FS475	FS411			43.10	
	90	FS675	FS611	FS411			38.79	
	80	FS675	FS675	FS611			34.48	
	70		FS675	FS675	FS611		30.17	
	60			FS475/FS675	FS611		25.86	
	50				FS675	FS611	21.55	
	40				FS675	FS611	17.24	
	100	200	300	400	500			
GALLONS PER MINUTE								

CHOOSING A MUNRO FS PUMP: FS6150/6220/8220 HP RANGE: 20 - 30												
TOTAL HEAD IN FEET	150	FS6220					64.65	PSI				
	140	FS6150	FS6220				60.34					
	130	FS6150	FS6150	FS6220			56.03					
	120	FS6150	FS6150	FS6220	FS6220		51.72					
	110	FS6150	FS6150	FS6150	FS6220		47.41					
	100	FS8220	FS8220	FS6150	FS6220		43.10					
	90				FS8220	FS6220	38.79					
	80				FS6150	FS8220	34.48					
	70				FS6150	FS8220	FS8220		FS8220	30.17		
	60				FS6150	FS8220	FS8220		FS8220	FS8220	25.86	
	50				FS6150	FS8220	FS6220		FS8220	FS8220	FS8220	21.55
		200	300	400	500	600	700		800	900	1000	
GALLONS PER MINUTE												

## Munro FS Series – 1/3 - 30 hp

### Specifications – Pump

HP	Phase	Discharge Size in	Weight lbs	Solids Handling in	Model Number
1/3	1	1.5	32	.24	FS250S11
		1.5	32	.24	FS250S22
1/2	1	2	33	.24	FS400S11
		2	33	.24	FS400S22
1	1	2	40	.32	FS750S11
	1	2	37	.32	FS750S22
	3	2	35	.32	FS750T22
	3	2	35	.32	FS750T44
2	1	2	83	.36	FS215S11
	1	2	81	.36	FS215S22
	3	2	70	.36	FS215T22
	3	2	60	.36	FS215T44
	1	3	83	.36	FS315S11
	1	3	81	.36	FS315S22
	3	3	59	.36	FS315T22
	3	3	78	.36	FS315T44
3	3	2	88	.36	FS222T22
		2	68	.36	FS222T44
		3	68	.36	FS322T22
		3	69	.36	FS322T44
5	3	2	142	.4	FS237T22
		2	122	.4	FS237T44
		3	143	.4	FS337T22
		3	135	.4	FS337T44
		4	145	.4	FS437T22
		4	144	.4	FS437T44
7.5	3	3	158	.4	FS355T22
		3	148	.4	FS355T44
		4	133	.4	FS455T22
		4	148	.4	FS455T44
10	3	4	300	.6	FS475T22
		4	300	.6	FS475T44
		6	300	.6	FS675T22
		6	300	.6	FS675T44
15	3	4	305	.6	FS411T22
		4	307	.6	FS411T44
		6	310	.6	FS611T22
		6	311	.6	FS611T44
20	3	6	313	.6	FS6150T22
		6	313	.6	FS6150T44
30	3	6	570	.8	FS6220T22
		6	570	.8	FS6220T44
		8	581	.8	FS8220T22
		8	581	.8	FS8220T44

SUBMERSIBLE

## Munro FS Series – 1/3 - 30 hp

### Specifications – Motor

HP	Voltage	Amps	Phase	Cord length ft.	Thermal Protection	Liquid Max Temp.	Model Number
1/3	110	4	1	18	Y	104° F	FS250S11
	220	2.5	1	18	Y		FS250S22
1/2	110	5.3	1	18	Y		FS400S11
	220	3	1	18	Y		FS400S22
1	110	10	1	18	Y		FS750S11
	220	5	1	18	Y		FS750S22
	220	4	3	18	Y		FS750T22
	440	2	3	18	Y		FS750T44
2	110	20	1	33	Y		FS215S11
	220	10	1	33	Y		FS215S22
	220	6	3	33	Y		FS215T22
	440	3	3	33	Y		FS215T44
	110	20	1	33	Y		FS315S11
	220	10	1	33	Y		FS315S22
	220	6	3	33	Y		FS315T22
	440	3	3	33	Y		FS315T44
3	220	8	3	33	Y		FS222T22
	440	4.5	3	33	Y		FS222T44
	220	9	3	33	Y		FS322T22
	440	4.5	3	33	Y		FS322T44
5	220	15	3	33	Y		FS237T22
	440	7.5	3	33	Y		FS237T44
	220	15	3	33	Y		FS337T22
	440	7.5	3	33	Y		FS337T44
	220	15	3	33	Y	FS437T22	
	440	7.5	3	33	Y	FS437T44	
7.5	220	25	3	33	Y	FS355T22	
	440	11.3	3	33	Y	FS355T44	
	220	22.5	3	33	Y	FS455T22	
	440	11.3	3	33	Y	FS455T44	
10	220	30	3	33	Y	FS475T22	
	440	15	3	33	Y	FS475T44	
	220	30	3	33	Y	FS675T22	
	440	15	3	33	Y	FS675T44	
15	220	45	3	33	Y	FS411T22	
	440	22.5	3	33	Y	FS411T44	
	220	45	3	33	Y	FS611T22	
	440	22.5	3	33	Y	FS611T44	
20	220	60	3	33	Y	FS6150T22	
	440	30	3	33	Y	FS6150T44	
30	220	90	3	33	Y	FS6220T22	
	440	45	3	33	Y	FS6220T44	
	220	90	3	33	Y	FS8220T22	
	440	45	3	33	Y	FS8220T44	

SUBMERSIBLE

# Munro FS Series – 1/3 - 30 hp

## Dimensions

MODELS: FS250/400/750

MODELS: FS215/315/222/322/237/  
337/437/355/455

MODELS: FS475/675/411/611

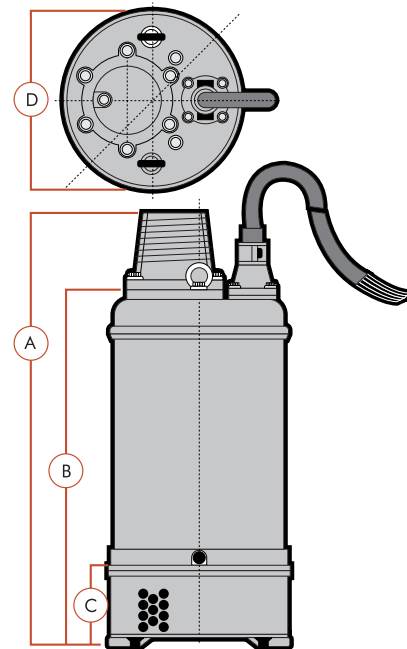
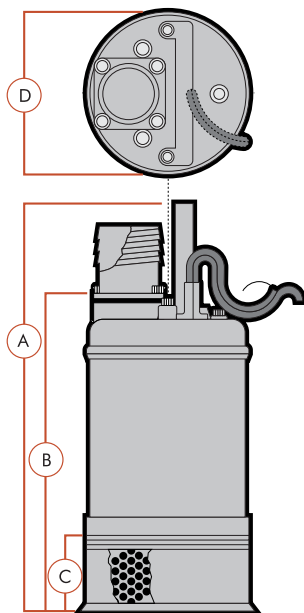
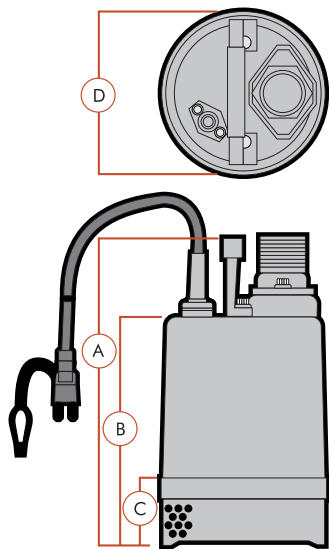

MODELS: FS6150

MODELS: FS6220/8220

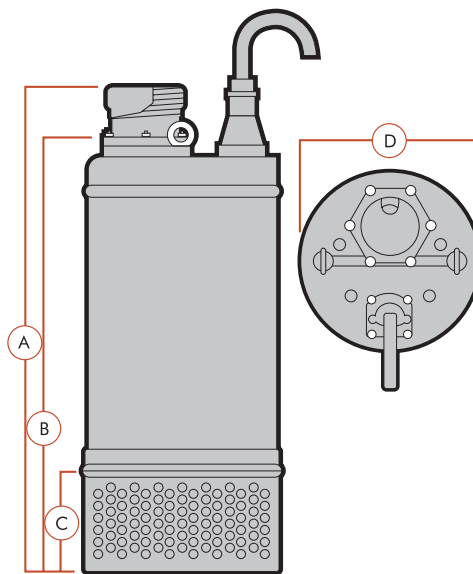
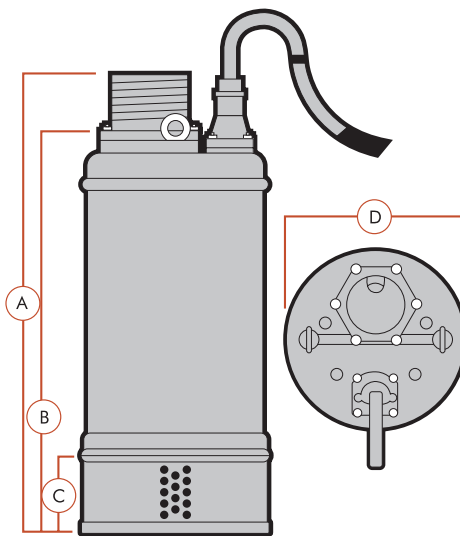

A	B	C	D	Model Number
13.375"	10"	3"	7.125"	FS-250/400
14.625"	11.25"	3"	7.125"	FS-750
22"	16"	2.875"	8.5"	FS-215/315
22"	16"	2.875"	8.5"	FS-222/322
25.25"	19.625"	4.75"	11.25"	FS-237/337/437
26.375"	20.625"	4.75"	11.25"	FS-355/455
33.25"	27.375"	7"	13.875"	FS-475/675
33.25"	27.375"	7"	13.875"	FS-411/611
36"	30"	5.75"	13.75"	FS6150
41"	37"	8"	16.5"	FS6220/8220

SUBMERSIBLE

## Munro FSR Series – 1/2 hp



The Munro FSR is specifically designed for continuous duty to extremely low levels of water. Ideal for pumping out basements or job sites where removing the maximum amount of water is desired. Designed to be easily carried from job to job. Sets up in minutes.

- **Specially designed rubber base** – will pump down to as little as 1/8" of fluid
- **Oil-free motor** – with thermal and over-current protector
- **Abrasion-resistant mechanical shaft seal** – protects the motor for longer life

### COMMON APPLICATIONS

Recommended for: dewatering

Other uses: water features, non-potable water transfer

### ADVANTAGES

**Pumps down to 1/8"** – When you need to get rid of fluid, especially on a flat surface, this pump is the one for you!

**Easy to use** – Just place in water and plug it in. Water enters from the bottom so this pump works both fully or partially submerged.

**Wear resistant materials** – Manufactured to withstand even the worst environment, high-quality materials mean this pump will keep on running, day after day, time after time.

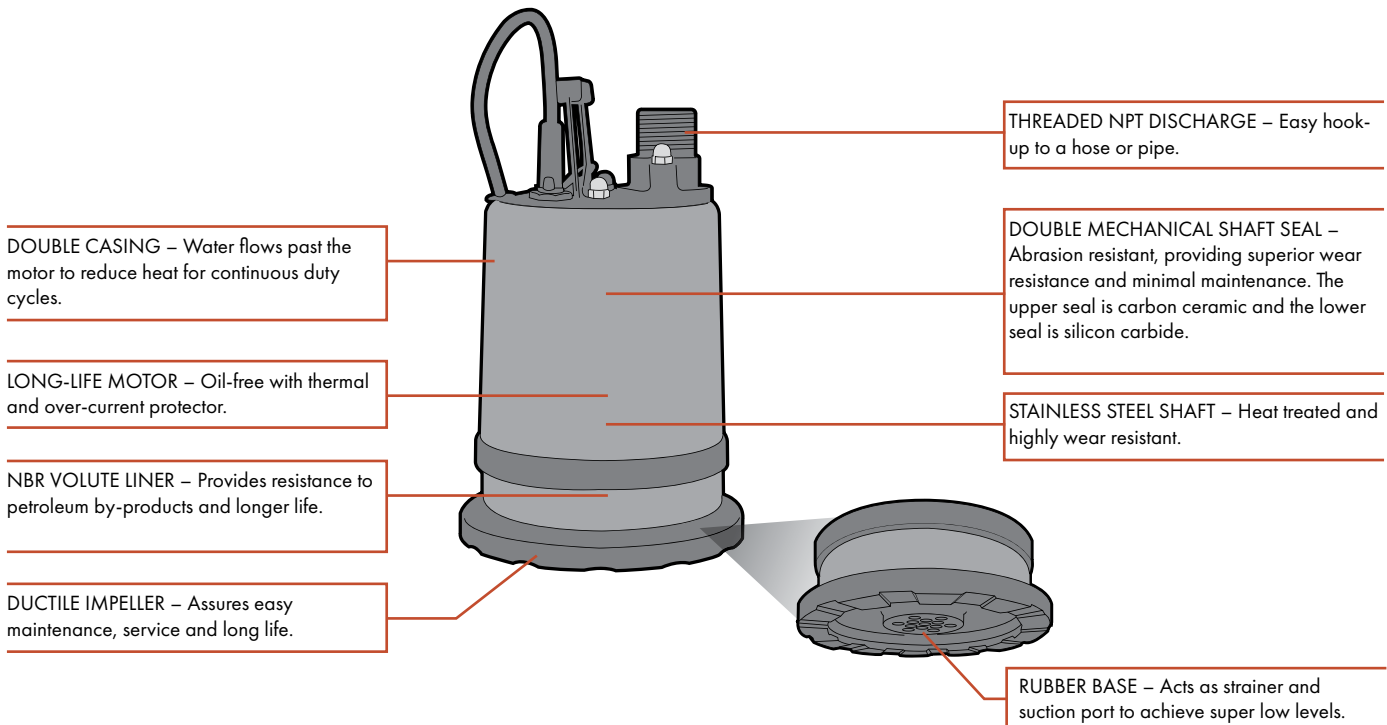

# Munro FSR Series

## Curves

HORSEPOWER RANGE: 1/2

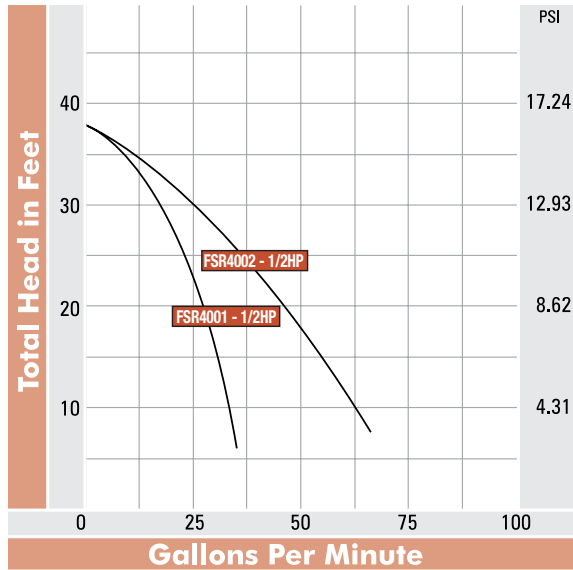

### Did You Know?

The FSR will pump down to 1/8" - Wow!

SUBMERSIBLE

## Dimensions

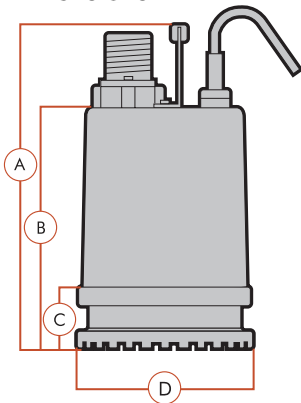

A	B	C	D	Model Number
13"	9.75"	3"	8.25"	FSR4001/4002

## Specifications - Pump

HP	Discharge	Solids Pass.	Max Head ft	Max Capacity gpm	Cord Length ft	Weight lbs	Model Number
1/2	1"	0.1"	38	34	10	31	FSR4001S11
	2"						FSR4002S11
	1"						FSR4001S22
	2"						FSR4002S22

## Specifications - Motor

HP	Volts	Amps	Thermal Protection	Solids Pass.	Liquid Max Temp.	Model Number
1/2	110	5.3	Y	0.24"	104° F	FSR4001S11
	110	5.3				FSR4002S11
	220	3				FSR4001S22
	220	3				FSR4002S22

## Munro FSL Series – 1/2 - 1 hp



Designed for continuous or intermittent duty, the Munro FSL Series pumps offer an excellent value and Munro's high-quality standards. This lightweight, yet heavy-duty pump has a compact design with unique double casing to reduce heat.

- **Abrasion-resistant mechanical shaft seal** – protects the motor for longer life
- **Polycarbonate impeller** – easy maintenance and quiet operation
- **Aluminum alloy outer case** – lightweight with excellent cooling effect

### COMMON APPLICATIONS

Recommended for: pondless and waterfall style water features  
Other uses: construction dewatering, non-potable utility

### ADVANTAGES

**Great performance at a great value** – This lightweight pump offers heavy-duty performance and delivers more gpm than most other pumps in its class.

**Continuous duty design** – These pumps are made to run! Our design takes the flow path across the motor housing to whisk away the heat generated by the motor. A cool motor means a longer life.

**Low cost to own** – Our pumps use lower amps than our competitors, which saves power and money.

**CORD RELIEF** – Designed to keep float cords out of the way.

**ALUMINUM ALLOY CASE** – Stands up to the elements.

**LONG-LIFE MOTOR** – Oil-free with thermal and over-current protector.

**POLYCARBONATE IMPELLER** – Increases efficiency.

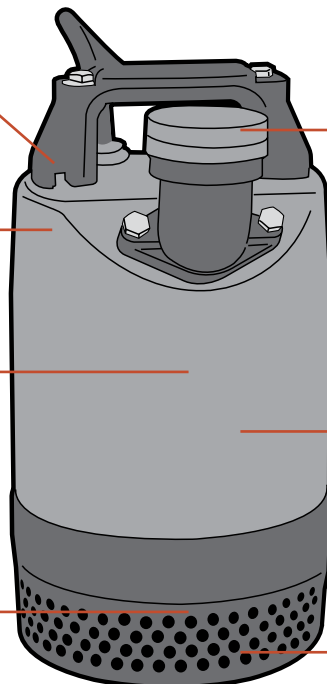

**THREADED NPT DISCHARGE** – Easy hook-up to a hose or pipe.

**DOUBLE MECHANICAL SHAFT SEAL** – Abrasion resistant, providing maximum motor protection with added oil reserve. The upper seal is carbon/ceramic and the lower seal is silicon/silicon.

**STRAINER INLET** – For added longevity and durability, passes up to .25" solids.

# Munro FSL Series – 1/2 - 1 hp

## Curves

HORSEPOWER RANGE: 1/2 - 1

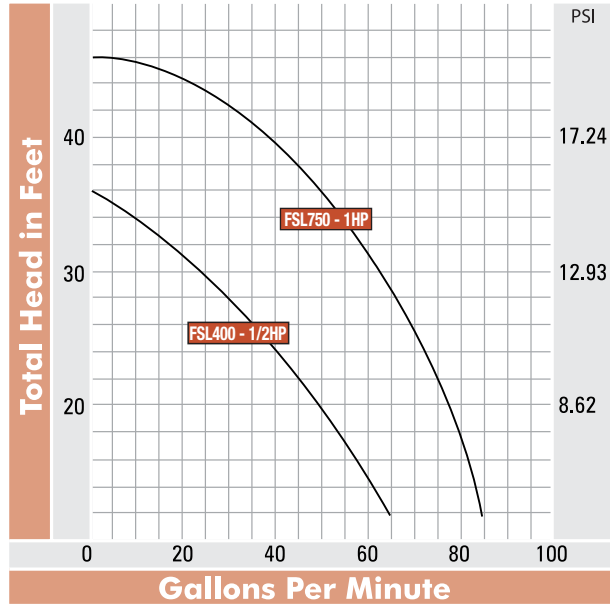

SUBMERSIBLE

## Dimensions

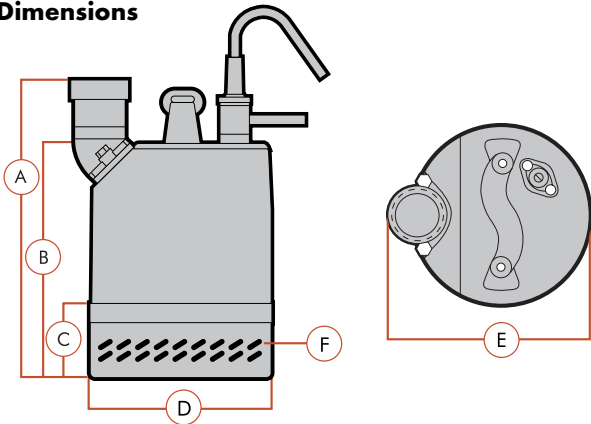

A	B	C	D	E	F	Model Number
11.875"	9.25"	2.75"	7.25"	8"	.25"	FSL400S11
13.125"	10.75"	3.5"	7.25"	8"	.25"	FSL750S11

## Specifications – Pump

HP	Discharge	Max Liquid Temp.	Solids Pass. in	Max Head ft	Max Capacity gpm	Weight lbs	Model Number
1/2	2"	100° F	0.2	36	63	16.5	FSL400S11
1			0.3	49	85	27.5	FSL750S11

## Specifications – Motor

HP	Volts	Amps	Cord Length ft	Thermal Protection	Model Number
1/2	110	5.3	10	Y	FSL400S11
1		10			FSL750S11

## Munro Residential Dewatering Series – 1/7 - 1/5 hp



Designed for continuous or intermittent duty, the Munro Residential Dewatering Series pumps offer an excellent value and Munro's high-quality standards. This space-saving, yet heavy-duty pump is low-water friendly and long lasting.

- **Abrasion-resistant mechanical shaft seal** – protects the motor for longer life
- **Self-protecting motor** – at high heat, automatic shutdown when there is no more fluid to pump
- **AAS plastic outer case** – durable and non-corrosive

### COMMON APPLICATIONS

Recommended for: dewatering, utility, sump, water features  
Other uses: hot tub drainage, pools, cooling water for machinery

### ADVANTAGES

**Low failure rate** – This pump has a failure rate well under 1% because the same build principles of superior design are used in Munro's larger pumps are used in the Residential Dewatering pump. A mechanical shaft seal protects this super efficient motor.

**True continuous duty design** – These pumps are made to run! Our design takes the flow path across the motor housing to whisk away the heat generated by the motor. A cool motor means a longer life.

**Low cost to own** – Our pumps use lower amps and provide higher flows than our competitors, which saves power and money.

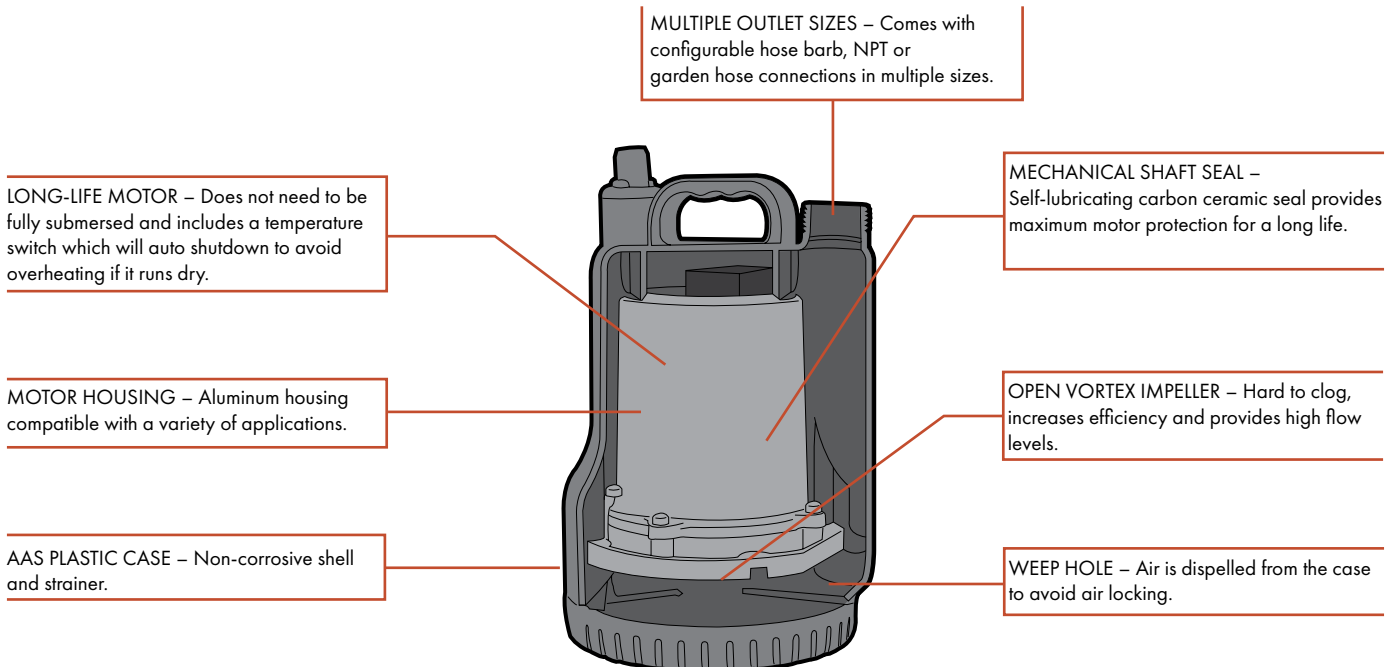

## Munro Residential Dewatering Series – 1/7 - 1/3 hp

### Curves

HORSEPOWER RANGE: 1/7 - 1/3

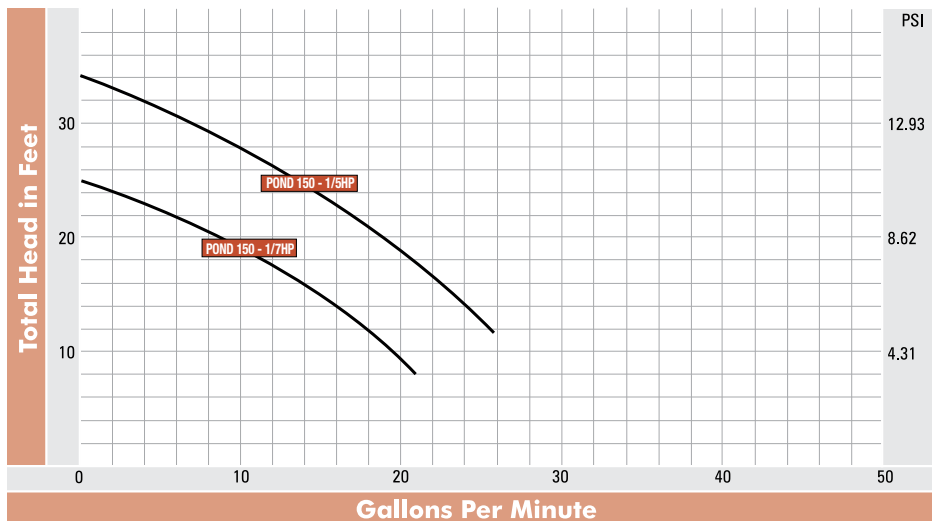

SUBMERSIBLE

### Dimensions

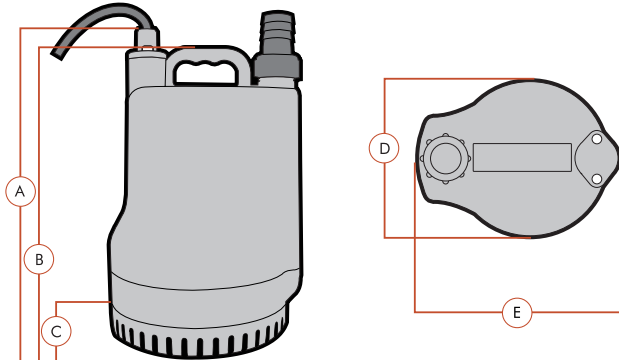

#### Did You Know?

Float controls can be added to signal pumps! See page 100.

A	B	C	D	E	Model Number
10"	9.5"	2"	6"	6.5"	POND100/150

### Specifications – Pump

HP	Discharge Options in	Max Head ft	Max Capacity gpm	Weight lbs	Solid Passage in	Model Number
1/7	5/8, 3/4, 1" Hose, 5/8" GHT, 1" NPT	25	21	9	.25	POND100
1/5		34	28	10	.25	POND150

### Specifications – Motor

HP	Volts	Phase	Amps	Thermal Protection	Cord Length ft	Liquid Max Temp.	Model Number
1/7	110	1	2	Y	10	104° F	POND100
1/5	110		3				POND150

## Submersible Sump Pumps

Sump pumps are made for removing groundwater and flood water from around a house or other building. They are most widely used in low lying areas and regions that get heavy rain.

The most important consideration for sump pumps is that they are durable and reliable. When one of these pumps goes out of service, it can be very inconvenient and the resulting flooding can cause thousands of dollars in property damage.

### A few considerations when you are buying a sump pump

#### 1. What will the pump be doing?

These versatile pumps can perform lots of different roles, but some are a better fit than others. Will you be emptying a sump after an occasional rain storm? Will the pump be cycling frequently, keeping seeping groundwater out of the house?

#### 2. Pedestal or submersible?

Submersibles are much quieter and more efficient, we always recommend a submersible over a pedestal pump.

#### 3. What size do you need?

Whether retrofitting an existing system or putting in a brand new system, it is important to note the measurements of your existing or new components – the diameter of the discharge pipe and the average amount of water that the pump will need to move.

#### 4. What materials are best for the job?

Because durability is so important in these types of pumps, it's worth making the investment in a pump made out of the highest quality materials possible. We offer a range of pumps and all of our pumps will stand up longer and stronger than our competitors.

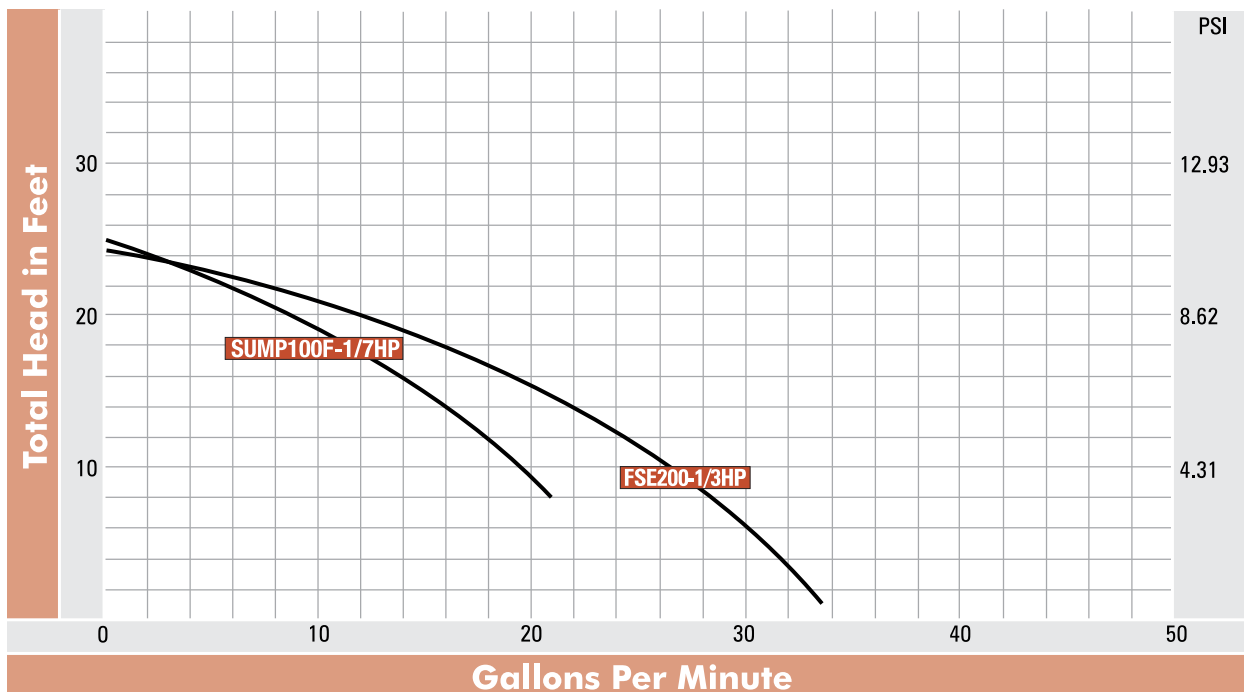

#### Did You Know?

Sump pumps should be checked for proper operation a couple of times per year – pour some water into the sump pit until the submersible pump cycles. This usually only takes a couple of minutes. Don't wait for a failure during a rainstorm to find out that the sump pump doesn't work!

## Munro Sump Series – 1/7 hp



Designed for continuous or intermittent duty, the Munro Sump pump offers an excellent value and Munro's high-quality standards. Often used in tight spaces for both sump and water features, this space-saving, yet heavy-duty pump is low-water friendly and long lasting.

- **Abrasion-resistant mechanical shaft seal** – protects the motor for longer life
- **Self-protecting motor** – at high heat, automatic shutdown when there is no more fluid to pump
- **AAS plastic outer case** – durable and non-corrosive

### COMMON APPLICATIONS

Recommended for: sump, water features, dewatering, utility  
Other uses: hot tub drainage, pools, cooling water for machinery

### ADVANTAGES

**Low failure rate** – This pump has a failure rate well under 1% because the same build principles of superior design are used in Munro's larger pumps are used in the Sump pump. A mechanical shaft seal protects this super efficient motor.

**True continuous duty design** – These pumps are made to run! Our design takes the flow path across the motor housing to whisk away the heat generated by the motor. A cool motor means a longer life.

**Low cost to own** – Our pumps use lower amps and provide higher flows than our competitors, which saves power and money.

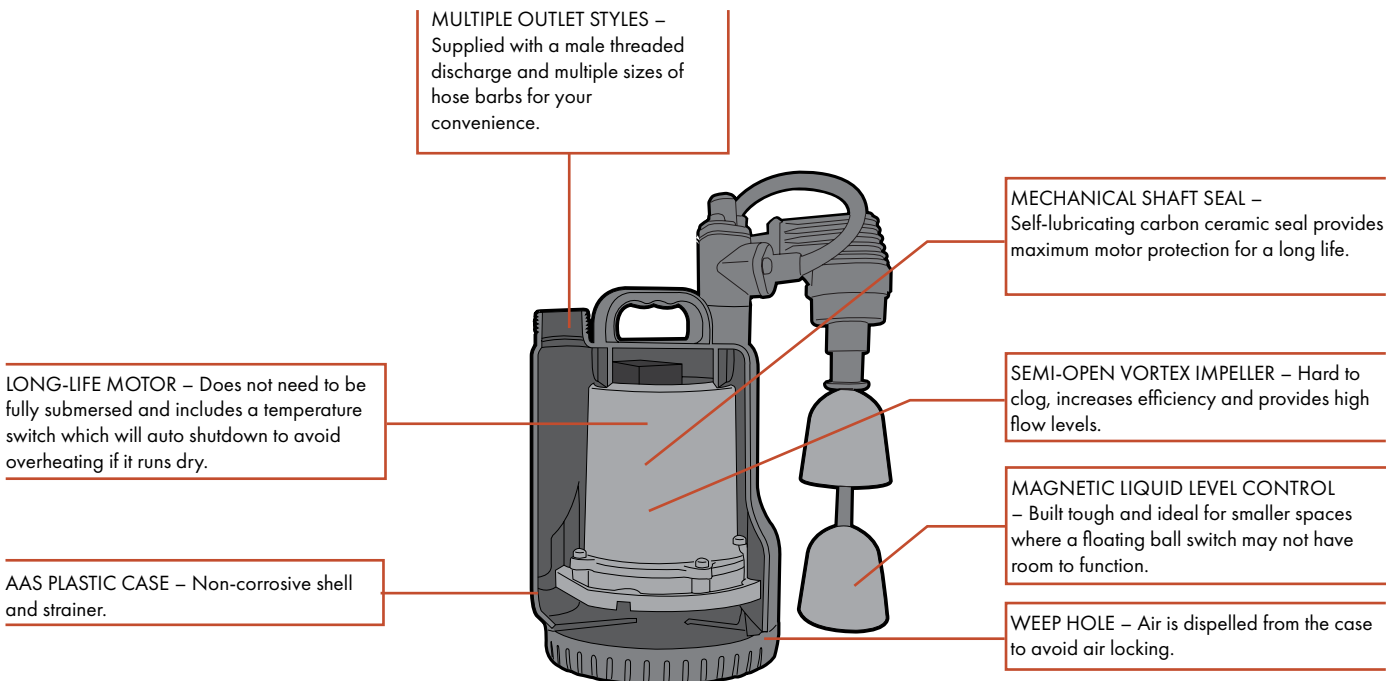

SUBMERSIBLE

## Munro Sump Series – 1/7 hp

### Curves

HORSEPOWER RANGE: 1/7

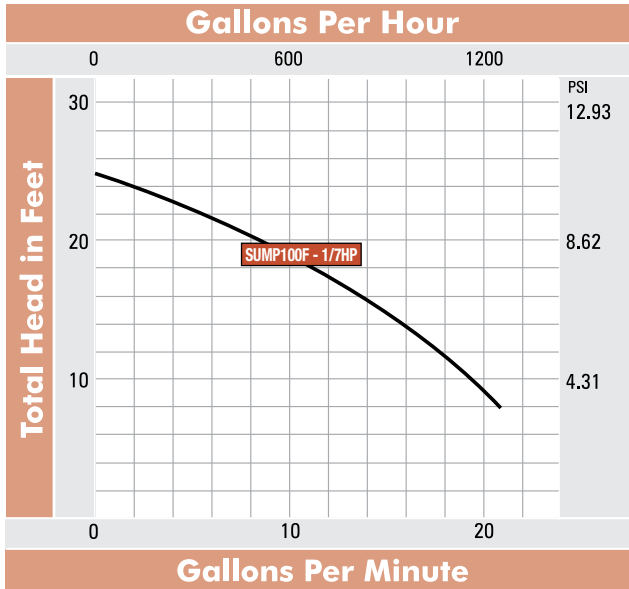

### Dimensions

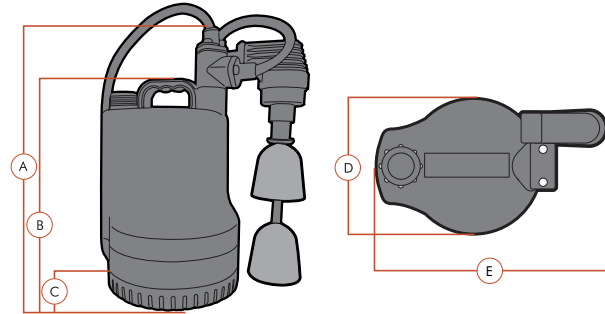

A	B	C	D	E
10.5"	10"	2"	6"	9"



#### Did You Know?

This automatic pump will fit inside of a 10" pipe?

### Specifications – Pump

HP	Discharge In.	Liquid Max Temp	Phase	Max Head ft	Max Capacity gpm	Max Capacity gph	Weight lbs	Solid Passage in	Model Number
1/7	1" NPT	104° F	1	25'	21	1,260	10	.157"	SUMP100F

### Specifications – Motor

HP	Volts	Phase	Amps	Thermal Protection	Cord Length ft	Model Number
1/7	110	1	2	Y	10'	SUMP100F

### Specifications – Float

Microswitch	Service	On/Off Switching Differentials in	Operating temp	Max Pressure psi	Dimensions in
20(8)A 250 V~	Continuous	Min 2" - Max 6"	32-120° F	7.25	2.36x9.25"

# Munro FSE – 1/3 hp Sump Pump



Designed for year-to-year operation in residential and light commercial sump applications, the Munro FSE is a great value for your basement dewatering or tank projects.

- **Stainless steel motor housing and shaft** – long lasting and low maintenance
- **Oil-free motor** – environmentally friendly, safe for fish and plants
- **Nylon fiber impeller** – durable and non-corrosive
- **Mechanical Float Switch** – monitors sump level

### COMMON APPLICATIONS

Recommended for: sump  
Other uses: utility, dewatering, effluent

### ADVANTAGES

**Extended duty design** – These pumps are made to run! A stainless steel, heat treated shaft and three shaft seals ensures a long life.

**Quiet and long lasting** – With a high-quality casing and impeller, this pump is a quiet workhorse.

**Great performance at a great value** – With our heavy-duty construction and versatile design, you’ll be pleasantly surprised when you compare this pump to its competition!

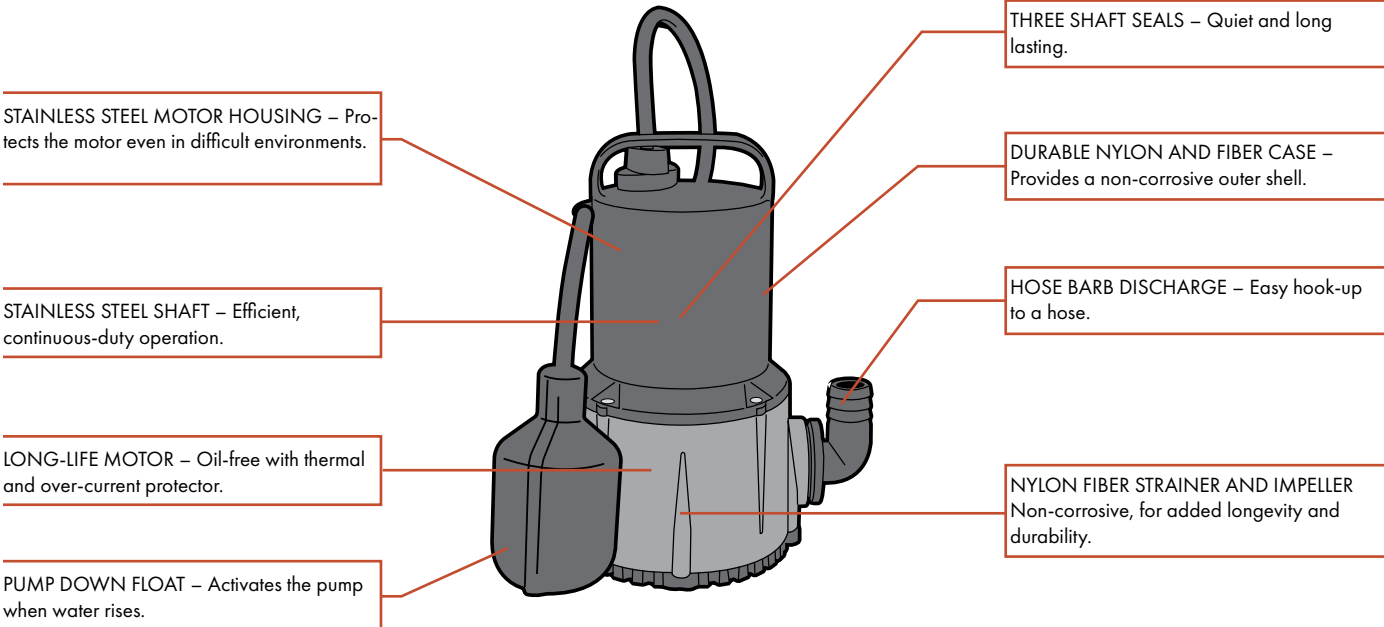

## Munro FSE – 1/3 hp Sump Pump

### Curves

HORSEPOWER RANGE: 1/3

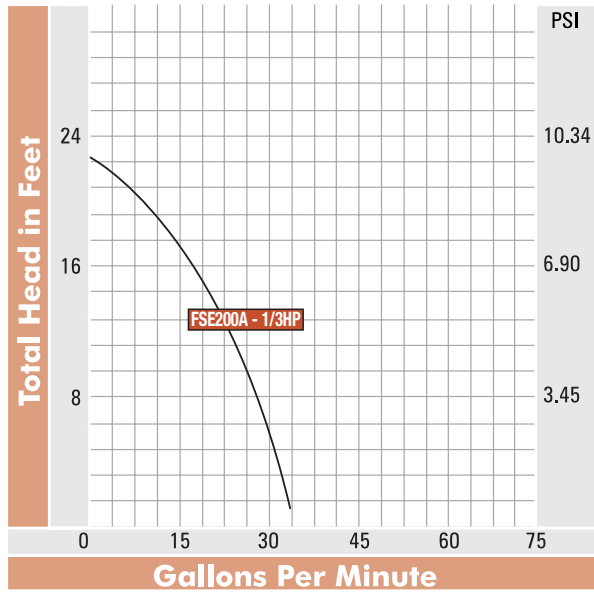

### Dimensions

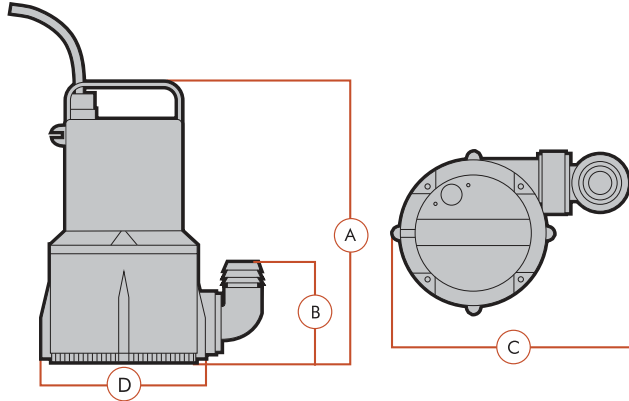

A	B	C	D	Model Number
10.125"	3.5"	7.5"	5.75"	FSE200S11

### Specifications – Pump

HP	Discharge	Max Liquid Temp.	Solids Pass. in	Max Head ft	Max Capacity gpm	Weight lbs	Model Number
1/3	1 1/4"	104° F	0.2	23	36	8.8	FSE200S11

### Specifications – Motor

HP	Volts	Phase	Amps	Cord Length ft	Thermal Protection	Model Number
1/3	110	1	4	10	Y	FSE200S11

## Submersible Sewage and Effluent Pumps

Effluent and sewage pumps are designed to pump waste and grey water from a home to a septic system or from a basement bathroom up to your sewage system. They are uniquely designed to pass solids. Munro's effluent pumps pass solids up to .25" and sewage pumps can handle approximately 1.4".

These pumps do dirty work, so it's important to select the most durable and reliable model that your budget will allow. When one of these pumps goes out of service, it can be very inconvenient and very costly.

### What makes effluent and sewage pumps different than most other submersibles?

#### 1. They can handle solids

This is key for sewage and grey water applications. A regular sump pump will not be able to handle the dirty fluid.

#### 2. They are made to run intermittently

Some submersibles are made to run continuously. These pumps are designed to run less often, but have more torque and power to eject water with solids or debris, as opposed to clean water.

#### 3. They do the dirty work

Our effluent and sump pumps are made of high quality materials so that they last longer in adverse conditions. If you have ever replaced a pump in a septic system, you know it's a dirty job and one that you hope to never deal with again. Therefore, it's worth it to upgrade to the best built pump possible.

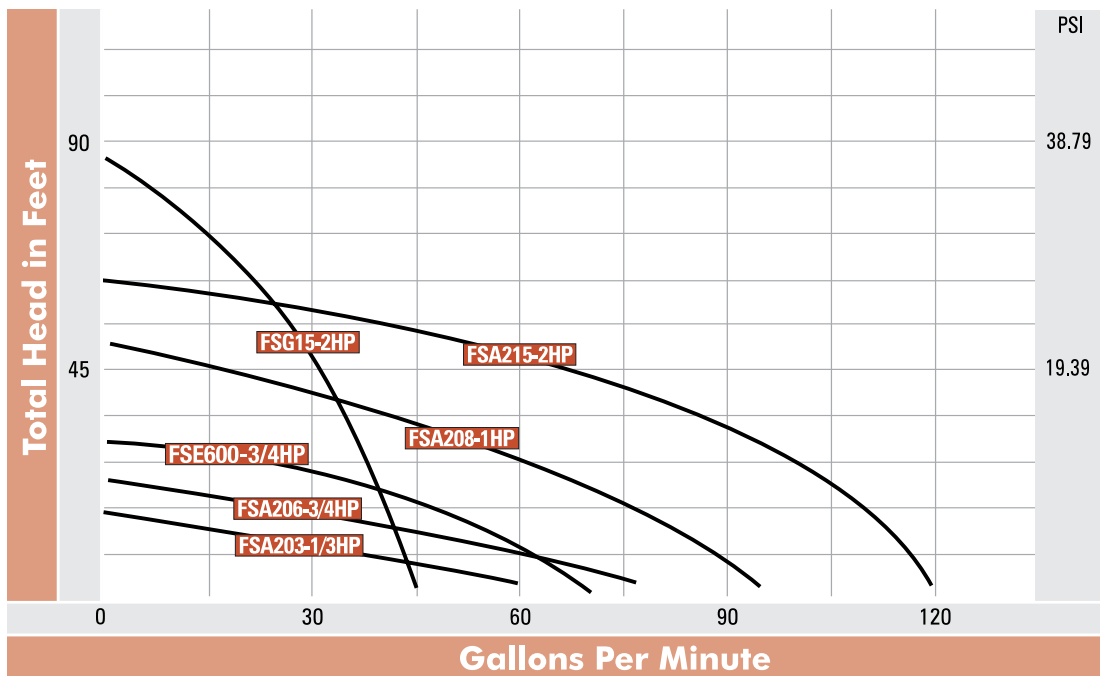

### Did You Know?

We recommend a tethered-style float switch because the solids in sewage & grey water can block the operation of a vertical-style switch and coat the contacts of an electronic-type switch – the more simple float switch lasts longer.



### Get everything you need!

Float controls can be found on page 100.

## Munro FSE – 3/4 hp Effluent Pump



SUBMERSIBLE

Designed for year-to-year operation in residential and light commercial applications, the Munro FSE is a great value for your effluent tank projects.

- **Stainless steel motor housing and shaft** – long lasting and low maintenance
- **Oil-free motor** – environmentally friendly
- **Nylon fiber impeller** – durable and non-corrosive
- **Mechanical float switch** – monitors water level

### COMMON APPLICATIONS

Recommended for: effluent

Other uses: utility, dewatering, sump

### ADVANTAGES

**Extended duty design** – These pumps are made to run! A stainless steel, heat treated shaft and three shaft seals ensures a long life.

**Quiet and long lasting** – With a high-quality casing and impeller, this pump is a quiet workhorse.

**Great performance at a great value** – With our heavy duty construction and versatile design, you'll be pleasantly surprised when you compare this pump to its competition!

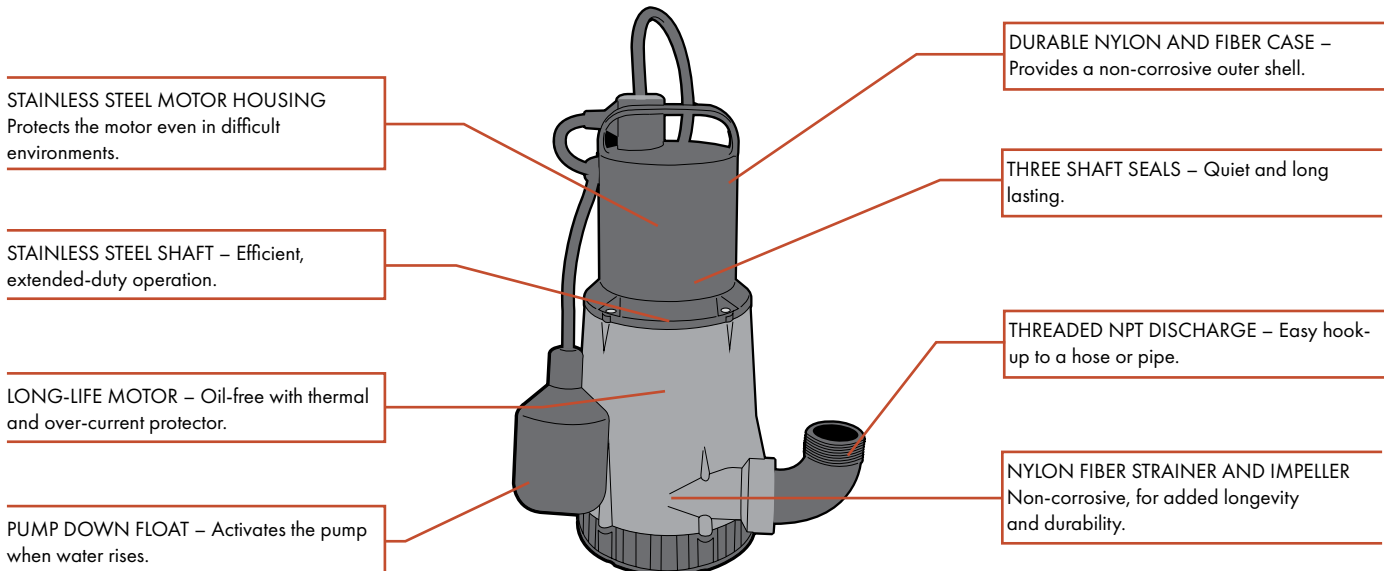

# Munro FSE – 3/4 hp Effluent Pump

## Curves

HORSEPOWER RANGE: 3/4

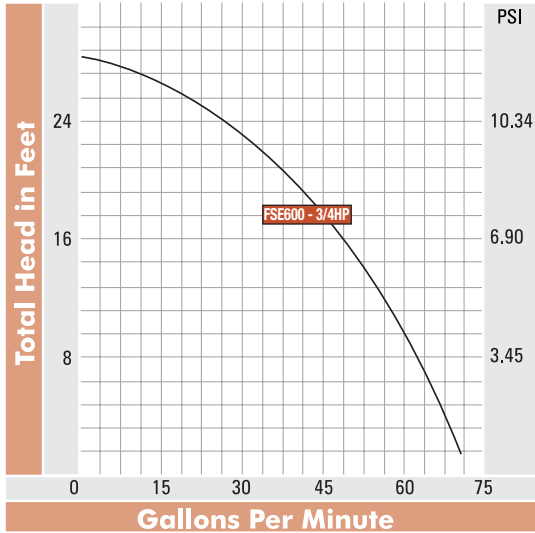

SUBMERSIBLE

## Dimensions

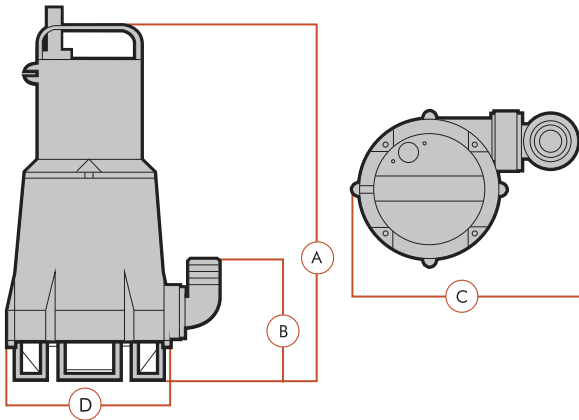

A	B	C	D	Model Number
14.5"	5.5"	9"	6.75"	FSE600S11

## Specifications – Pump

HP	Discharge	Max Liquid Temp.	Solids Pass. in	Max Head ft	Max Capacity gpm	Weight lbs	Model Number
3/4	1 1/4"	104° F	0.3	30	69	12.1	FSE600S11

## Specifications – Motor

HP	Volts	Phase	Amps	Thermal Protection	Cord Length ft	Model Number
3/4	110	1	8	Y	20	FSE600S11

## Munro FSA Sewage Pumps – 1/3 - 3/4 hp



SUBMERSIBLE

The Munro FSA pumps provide years of trouble-free performance in residential and light commercial sewage and effluent applications. The very compact design is built to meet your most demanding requirements.

- **Stainless steel and thermoplastic casing** – lightweight with superior corrosion resistance
- **Ceramic seal** – allows for continuous operation
- **Vortex impeller** – provides superior solids handling

### COMMON APPLICATIONS

Recommended for: sewage

Other uses: effluent

### ADVANTAGES

**Extended duty design** – Designed for on-demand intermittent use, this sewage pump will provide years of service, extending the life and limiting service and replacements.

**Quiet and long lasting** – With a stainless steel shaft and dual ball bearings, this pump offers low corrosion components for long-term use.

**Premium performance** – Heavy-duty construction provides trouble-free performance, even in demanding situations.

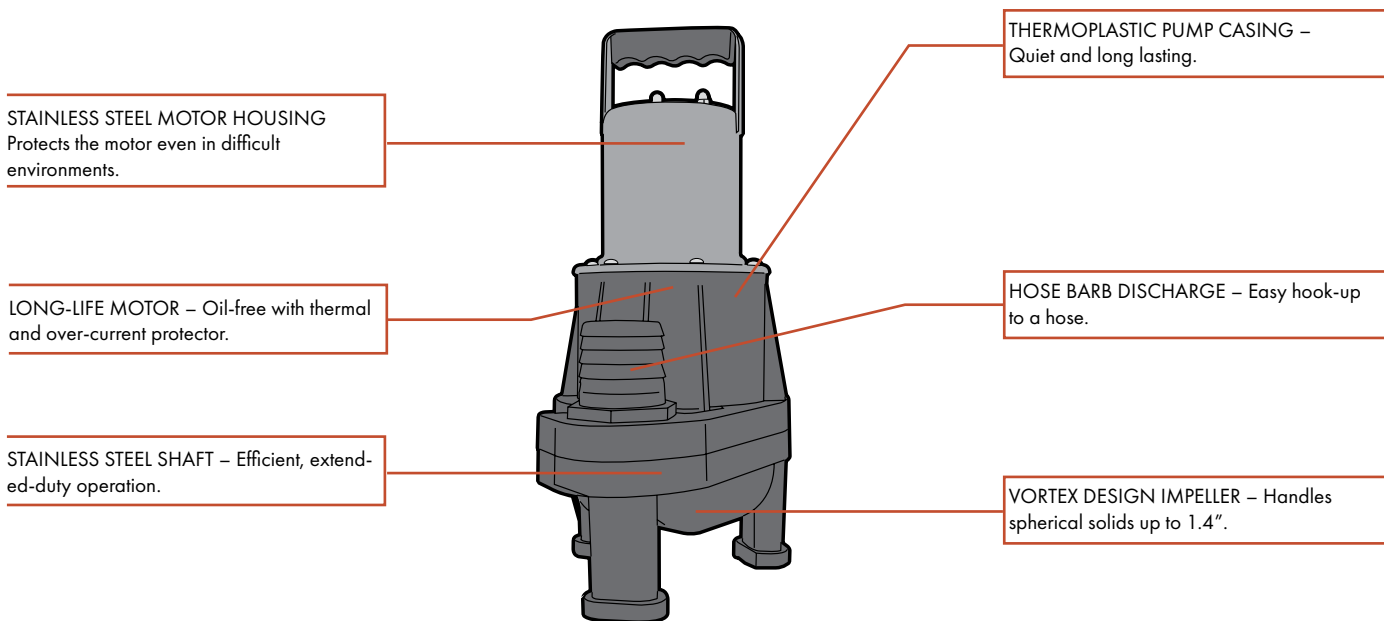

## Munro FSA Sewage Pumps – 1/3 - 3/4 hp

### Curves

HORSEPOWER RANGE: 1/3 - 3/4

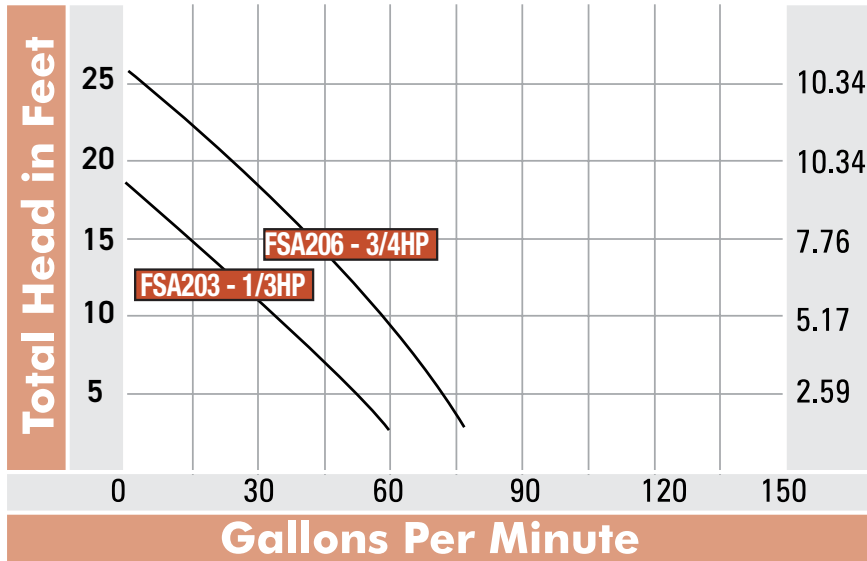

SUBMERSIBLE

### Dimensions

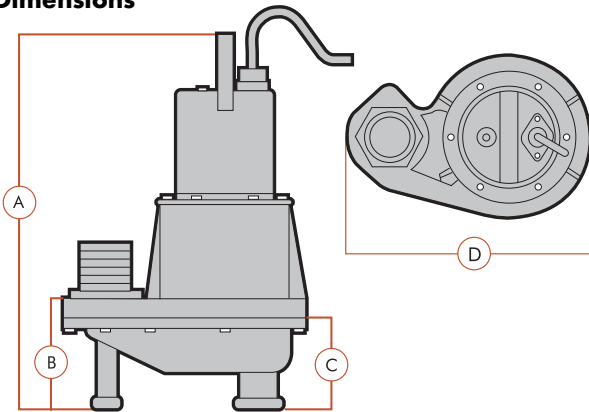

A	B	C	D	Model Number
13.375" 14.75"	4.625"	3.75"	9.50"	FSA203S11 FSA206S11

### Specifications – Pump

HP	Discharge in	Max Liquid Temp.	Solids Pass. in	Max Head ft	Max Capacity gpm	Weight lbs	Model Number
1/3	2	104° F	1.4	23	58	9.2	FSA203S11
3/4	2		1.4	31	74	13.2	FSA206S11

### Specifications – Motor

HP	Volts	Phase	Amps	Thermal Protection	Cord Length ft	Model Number
1/3	110	1	4	Y	10	FSA203S11
3/4			8		20	FSA206S11

## Munro FSA Industrial Survivor Sewage Pumps – 1 - 2 hp

SUBMERSIBLE



The Munro Industrial Survivor pumps provide superior sustainability and performance, even in the most difficult environments and demanding requirements. While no pump is ever “fit and forget”, these extra heavy-duty pumps have proven their durability year-after-year and have earned customer accolades for long-term intermittent use.

- **All stainless steel** – to stand up to the worst conditions
- **Double mechanical seal** – allows for extended-duty operation
- **Oil-free motor** – thermal and over-current protection

### COMMON APPLICATIONS

Recommended for: commercial

Other uses: residential sewage

### ADVANTAGES

**All stainless steel** – This hearty pump boasts a stainless steel cover and frame as well as cast stainless steel impeller, suction case and shaft, to stand up to high temperatures and harsh external conditions. This pump just screams quality.

**Premium performance** – Heavy-duty construction provides trouble-free performance, even in the most demanding situations.

STAINLESS STEEL HOUSING AND FRAME – Protects the motor even in difficult environments.

LONG-LIFE MOTOR – Oil-free with thermal and over-current protector.

CAST STAINLESS STEEL, HEAVY DUTY IMPELLER AND SHAFT – Efficient, extended-duty operation.

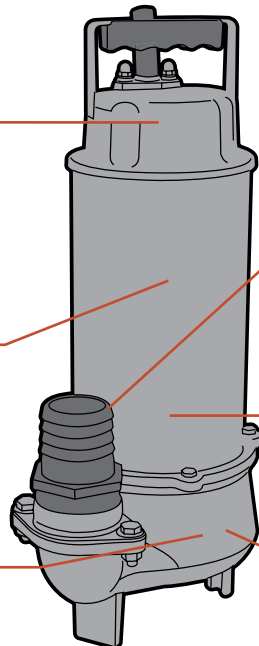

HOSE BARB DISCHARGE – Easy hook-up to a hose.

DOUBLE MECHANICAL SHAFT SEAL – Abrasion-resistant, providing superior wear resistance and minimal maintenance. The upper seal is carbon/ceramic and the lower seal is silicon/carbide.

CAST STAINLESS STEEL WET END – Stands up to harsh environments.

## Munro FSA Industrial Survivor Sewage Pumps – 1 - 2 hp

### Curves

HORSEPOWER RANGE: 1 – 2

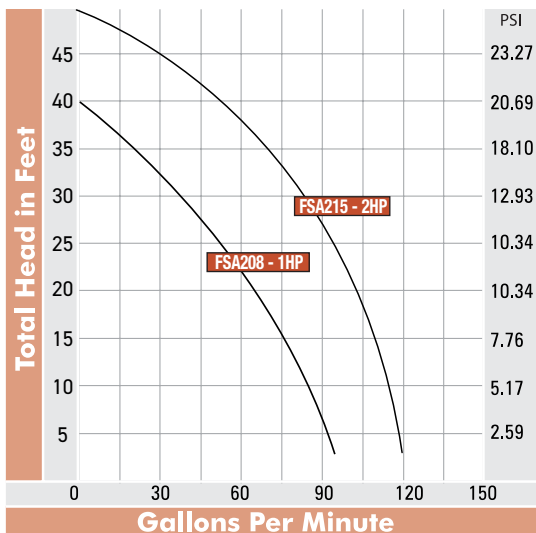

#### Did You Know?

With cast stainless steel bracket, case and impeller, this pump is one of the most heavy-duty pumps on the market!

SUBMERSIBLE

### Dimensions

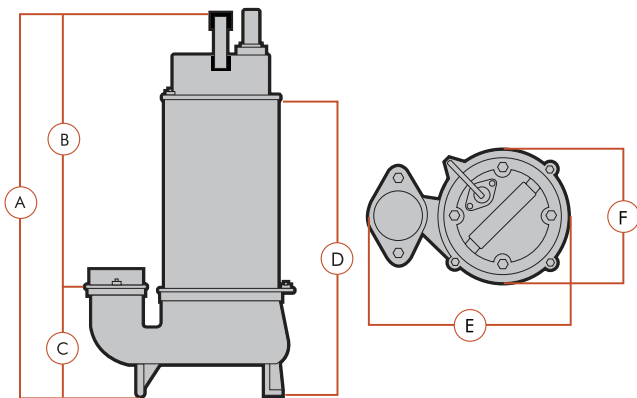

A	B	C	D	E	F	Model Number
16.125" 17.25"	11.25" 12.375"	4.75"	12.125" 13.25"	9.125"	6.125"	FSA208S11/S22 FSA215

### Specifications – Pump

HP	Discharge in	Max Liquid Temp.	Solids Pass. in	Max Head ft	Max Capacity gpm	Weight lbs	Model Number
1	2	104° F	1.6	49	95	26.4	FSA208S11
1				49	95	26.4	FSA208S22
2				59	122	33.0	FSA215S22

### Specifications – Motor

HP	Volts	Phase	Amps	Thermal Protection	Cord Length ft	Model Number
1	110	1	10	Y	19	FSA208S11
1	220		5			FSA208S22
2	220		10			FSA215S22

## Munro FSG Sewage Grinder Pumps – 2 hp



The Munro FSG Grinder Pump's non-clogging design, small discharge, and high pressure make it ideal for individual residential and light industrial sewer applications.

- **Rigid cast iron construction** – superior for heat dissipation
- **High chrome steel grinding device** – unique cutter designed with chopper and chopper ring will stand up to difficult environments
- **Stainless steel shaft** – heat-treated to last longer

### COMMON APPLICATIONS

Recommended for: sewage

Other uses: effluent

### ADVANTAGES

**Extended duty service** – Whether running this pump for hours or minutes at a time, the double mechanical seals and oil-free motor ensure a long life.

**Non-clogging design** – The high chrome steel chopper and chopper ring will keep solids macerated and moving.

**Premium performance** – Heavy-duty construction provides trouble-free performance, even in demanding situations.

CAST IRON CONSTRUCTION – Superior for heat dissipation.

LONG-LIFE MOTOR – Oil-free with thermal and over-current protector.

CAST IRON IMPELLER – Dynamically balanced.

STAINLESS STEEL SHAFT – Long lasting, extended-duty operation.

HIGH CHROME STEEL GRINDING DEVICE – Superior hardness.

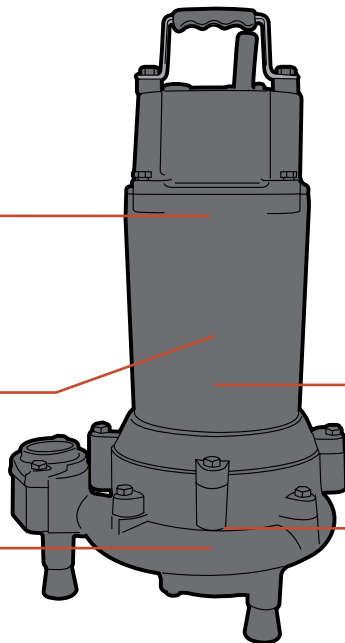

## Munro FSG Sewage Grinder Pumps – 2 hp

### Curves

HORSEPOWER RANGE: 2

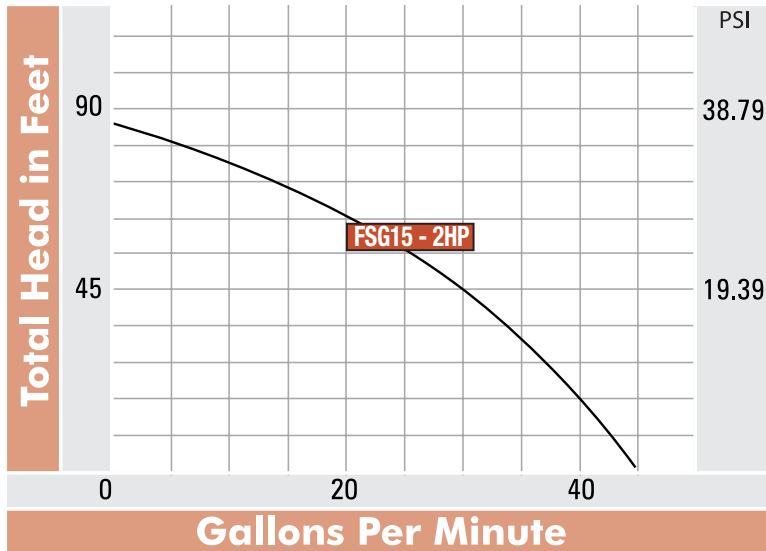

### Did You Know?

With the capacitor mounted in the motor, this unit will replace most grinder pumps easily and does not need a starting capacitor in a remote panel.

SUBMERSIBLE

### Dimensions

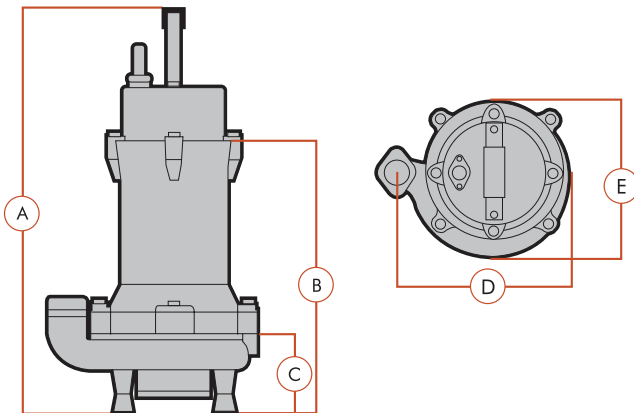

A	B	C	D	E	Model Number
15.125"	14.75"	4"	10"	8.75"	FSG15S22

### Specifications – Pump

HP	Discharge in	Max Liquid Temp.	Solids Pass. in	Max Head ft	Max Capacity gpm	Weight lbs	Model Number
2	1 1/4	104° F	.1	98	42	77	FSG15S22

### Specifications – Motor

HP	Volts	Phase	Amps	Starting Capacitor	Thermal Protection	Cord Length ft	Model Number
2	230	1	20	Y	Y	31	FSG15S22

# MULTISTAGE SUBMERSIBLE PUMPS

## Submersible Water Harvesting Pumps

Multistage submersible pumps are designed to bring water up to the surface for use in a variety of applications, most often for domestic and irrigation use. Because sub-surface water is an important water source for many people, choosing the right pump is very important.

### Shallow well pumps vs deep well pumps

**Shallow well** pumps are found in applications at sea level (25' or less). This style of well pump is not submersible and is placed outside the well in a well house.

A key feature you should look for is overload protection, which prevents motor burnout. The best shallow well pumps are accompanied by a diaphragm storage tank or a booster to increase PSI, in order to provide constant water pressure to a home. If size is a restriction due to the well house, choose a pump with a booster as this will take up less space.

**Deep well** pumps can be used in wells as deep as 1000' below ground. Unlike shallow well pumps, deep well pumps are submerged inside the well to allow the impellers to push the water up.

Since these pumps can be several hundred feet below ground, a 3-wire model makes maintenance easier. In a 3-wire model the starter controls are above ground, wired to the pump. A 2-wire model is easier to install, but, should the pump fail, you'll need to bring it up to ground level to fix or replace the electrical controls.

## Water Harvesting Application

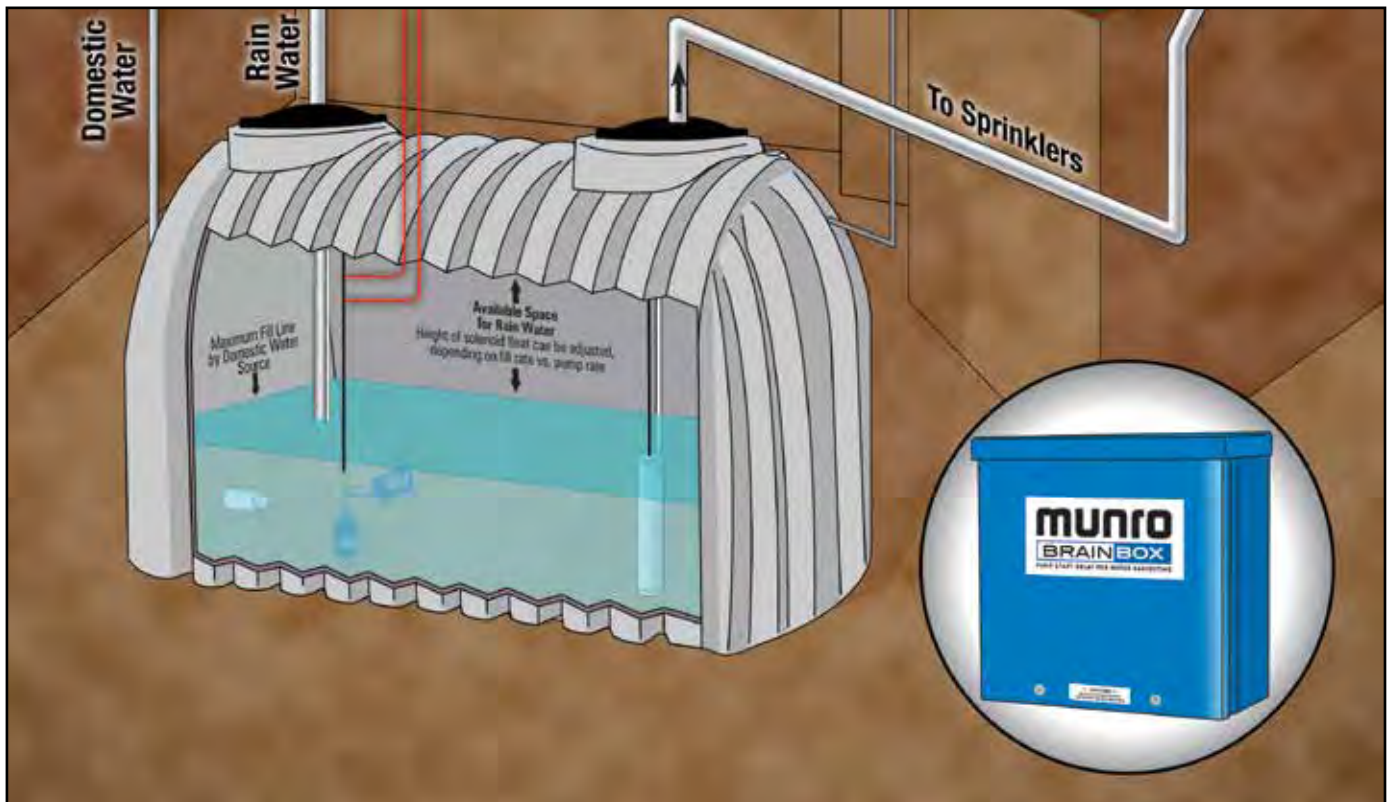

## Munro 5" Multistage Bottom Suction Submersible Pumps



### Water Harvesting Sprinkler Pump

Our easy-to-install, high-head multistage submersible pump is designed for turf irrigation service, high head dewatering applications, and high pressure, low gallonage water feature projects that require high head and low flow (i.e., fountains).

- **Stainless steel components outside and inside** – non-corrosive, built to industrial specifications
- **Self-cooling, quiet operation** – the pumped liquid cools the motor for long life
- **Easy installation** – no control box required to start the pump

### COMMON APPLICATIONS

- Recommended for: irrigation, shallow wells, rain collection tanks, grey water
- Other uses: dewatering, fountains, pressure boosting domestic water

### ADVANTAGES

**Non-corrosive** – All hydraulic parts, including impellers and hydraulic bowl chambers, are made from high-grade stainless steel.

**Superior “Draw-Down” Capability** – With the lowest draw down in its class, our 4 1/2” capability dwarfs the competition.

**Reduced Amp Draw** – Offering over 25% less energy consumption reduces operating costs and extends the service life.

**Cooler and Quieter Operation** – Using the pumped liquid to cool the motor, the water passing over the motor dampens the noise. No need for expensive “flow-inducer sleeves” required on other pumps.

SUBMERSIBLE

STAINLESS STEEL SHELL – Heavy-walled and corrosion resistant.

STAINLESS STEEL SHAFT – Offers generous impeller drive surfaces.

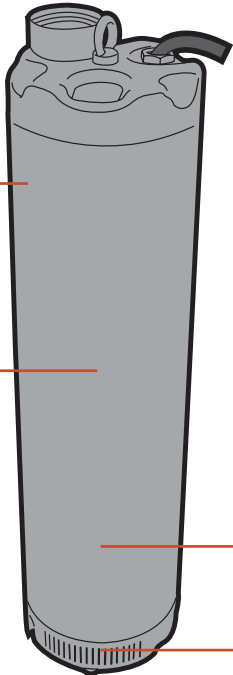

STAINLESS STEEL IMPELLERS – Perfectly balanced and ultra smooth for the highest performance and efficiency.

INTEGRATED INLET – Allows .08” (5/64th) solids.



### Get Everything You Need!

- Add check valve (p.176)
- Add Float Control (p.100)

## Munro 5" Multistage Bottom Suction Submersible Pumps

### Curves

HORSEPOWER RANGE: 3/4 – 2

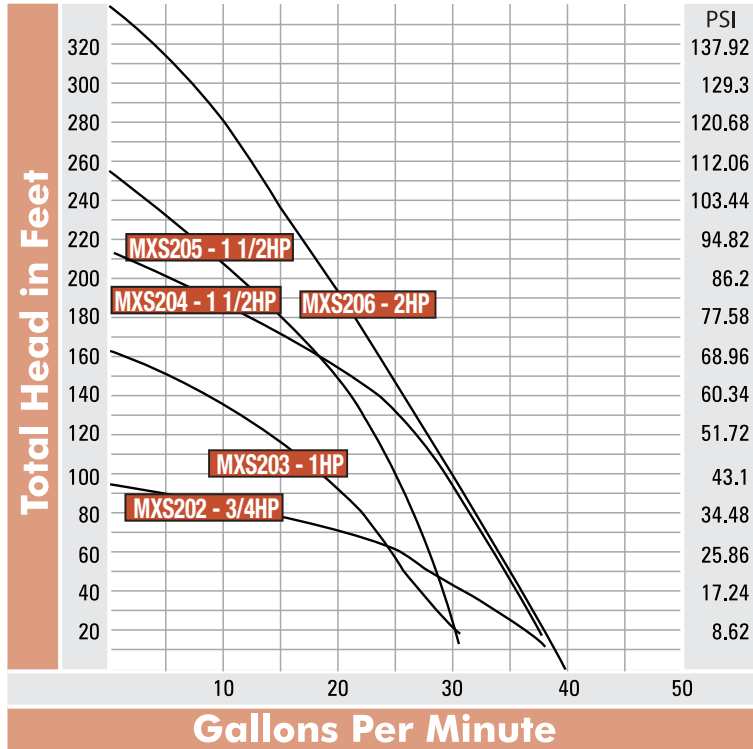

### Specifications – Pump

HP	Discharge in	Liquid Max Temp.	Diameter in	Approx. Length in	Weight lbs	Model Number
3/4	1.25	104° F	5	15.75	29	MXS202S11
1				17.5	29	MXS203S11
1				17.5	29	MXS203S22
1 1/2				20	38.5	MXS204S11
1 1/2				20	38.5	MXS204S22
1 1/2				21	40	MXS205S11
1 1/2				21	40	MXS205S22
2				23	46	MXS206S22
1				17.25	30.64	MXS203T22
1 1/2				20.25	36.38	MXS205T22

### Specifications – Motor

HP	Volts	Phase	Amps	Thermal Protection	Cord Length ft	Model Number
3/4	110	1	8.5	Y	15 (16/3 Gauge)	MXS202S11
1	110		10.5			MXS203S11
1	220		5			MXS203S22
1 1/2	110		13.5			MXS204S11
1 1/2	220		7			MXS204S22
1 1/2	110		16			MXS205S11
1 1/2	220		8			MXS205S22
2	220		9.5			MXS206S22
1	220	3	3.6	N		MXS203T22
1 1/2	220		5.5			MXS205T22

## 4" Submersible Well Pumps – 1/2 - 20 hp



Constructed of high-quality components, these well pumps are designed to be used vertically. A check valve comes standard on all models. If the well pump is positioned in an open body of water, a flow sleeve must be used (p.70)

- **Durable stainless impellers** – low maintenance and long lasting
- **Self-lubricating bearing** – resists sand and abrasives
- **Universal setup** – good replacement for any other existing well pump

### COMMON APPLICATIONS

- Recommended for: irrigation, pressure boosting domestic water
- Other uses: potable water supply

### ADVANTAGES

**High-quality construction** – Stainless steel impellers give this pump a longer, multi-functional and trouble-free life.

**Flexible and forgiving** – Constructed to meet the demands of challenging environments, such as acidic or high-mineral content fluid.

**Wide range of sizes and configurations** – You'll find just the size and construction you're looking for to meet the requirements for your application. We offer variable speed options and a wide range of sizes and constructions.

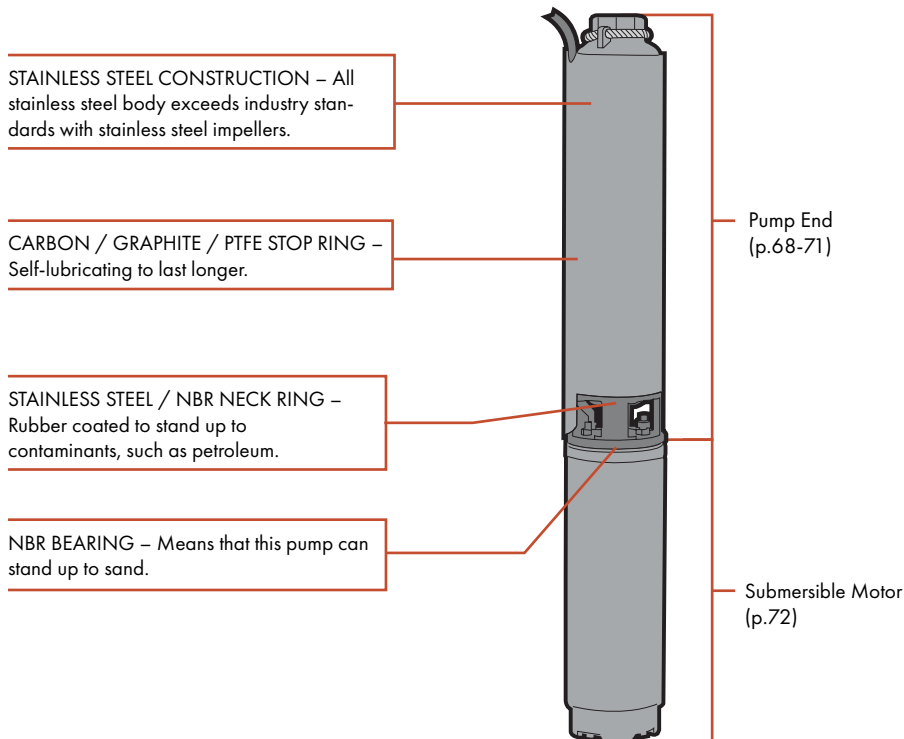

### Did You Know?

Two-wire and three-phase motors available and on the shelf! (p.72)

Constant pressure systems available to eliminate that huge pressure tank! (p.73)

NOTE: Pump Ends and Submersible Motors are sold separately.

## 4" Submersible Well Pumps 5 & 7 GPM Series

### Curves

HORSEPOWER RANGE: 1/2 – 2

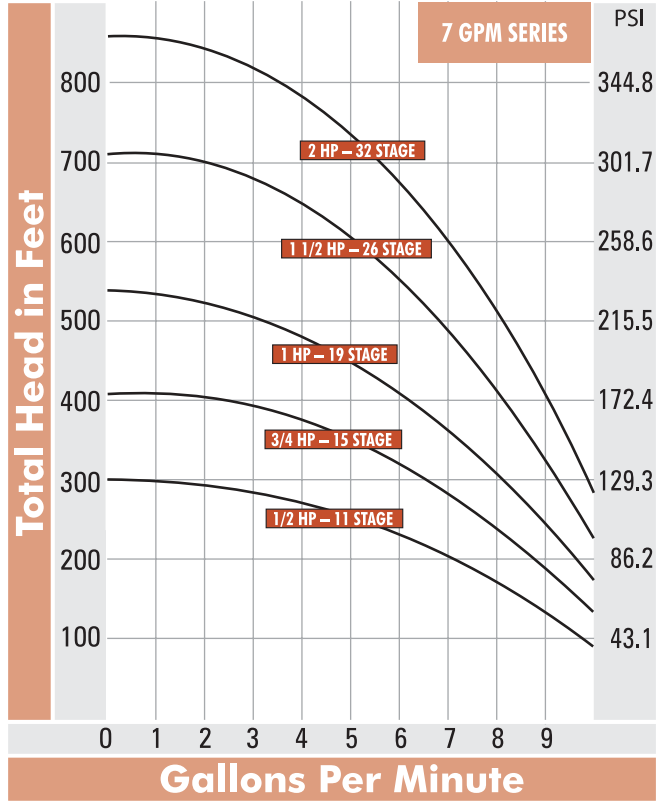
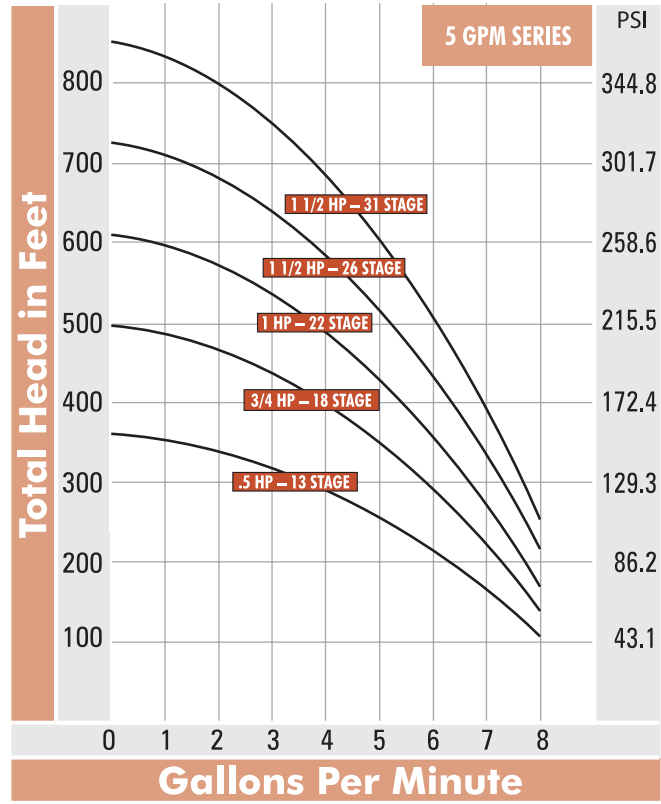

### Get Everything You Need!

- Pump saver (p.105)
- Cable + splice kit (p.106)
- Flow control valve (p.179)
- Check valves (p.176)
- Flow sleeve (p.74)

**Specifications** Pump End only. Submersible motors (p.68) must be selected and purchased separately.

HP	Diameter in	Discharge in	GPM	Approx. Length in	Weight lbs	Liquid Max Temp.	Model Number
1/2	3.9	1 1/4	5	17.3	8	104° F	WI6034863
3/4				21.5	10		WI6034864
1				24.8	12		WI6034865
1 1/2				28.1	13		WI6034866
1 1/2				33.1	20		WI6034867
1/2	3.9	1 1/4	7	15.2	10	104° F	WI2707563
3/4				18.5	11		WI2707564
1				21.8	12		WI2707565
1 1/2				27.6	16		WI2707566
2				34.5	28		WI2707567

## 4" Submersible Well Pumps 10 & 18 GPM Series

### Curves

HORSEPOWER RANGE: 1/2 – 10

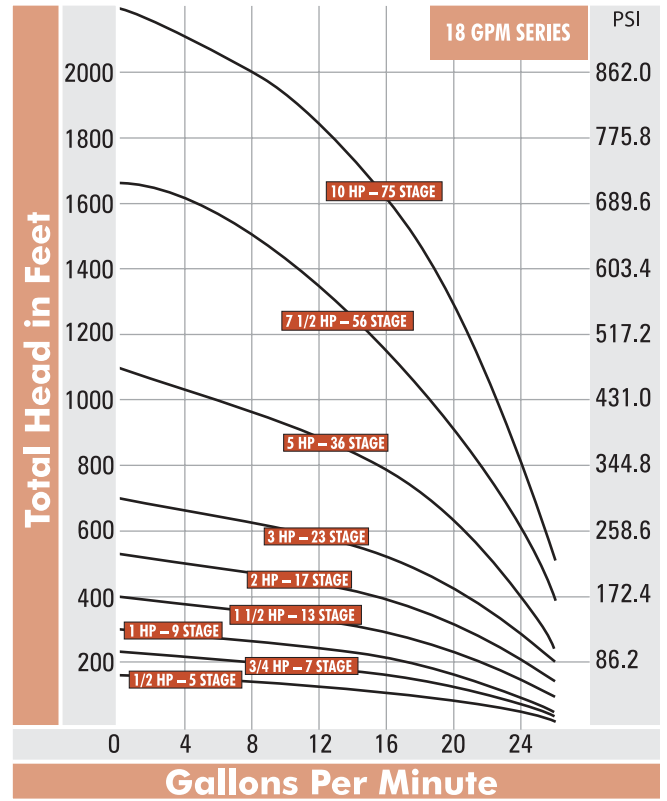
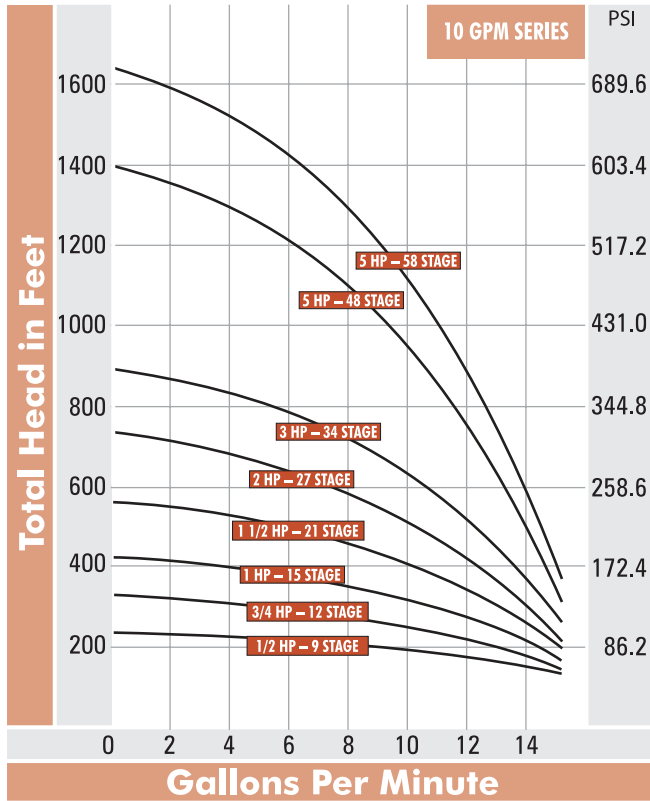

SUBMERSIBLE

**Specifications** Pump End only. Submersible motors (p.72) must be selected and purchased separately.

HP	Diameter in	Discharge in	GPM	Approx. Length in	Weight lbs	Liquid Max Temp.	Model Number			
1/2	3.9	1 1/4	10	14	7	104° F	WI6034869			
3/4				16.5	8		WI6034870			
1				19	9		WI6034871			
1 1/2				23.9	12		WI6034872			
2				28.9	14		WI6034873			
3				35.6	22		WI6034874			
5				47.7	38		WI6064249			
5				64.5	42		WI6064250			
1/2				3.9	1 1/4		18	10.7	5	WI6034875
3/4								12.4	6	WI6034876
1	14	7	WI6034877							
1 1/2	17.3	9	WI6034878							
2	20.6	10	WI6034879							
3	25.6	13	WI6034880							
5	37.2	23	WI6034882							
7 1/2	68.8	45	WI6065308							
10	84.5	60	WI6064251							

## 4" Submersible Well Pumps 25 & 40 GPM Series

### Curves

HORSEPOWER RANGE: 1/2 – 20

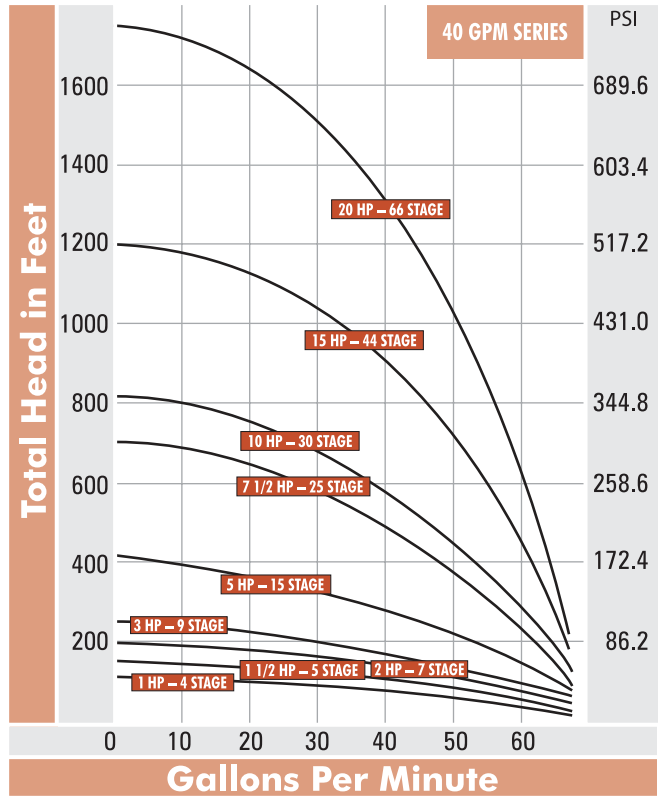
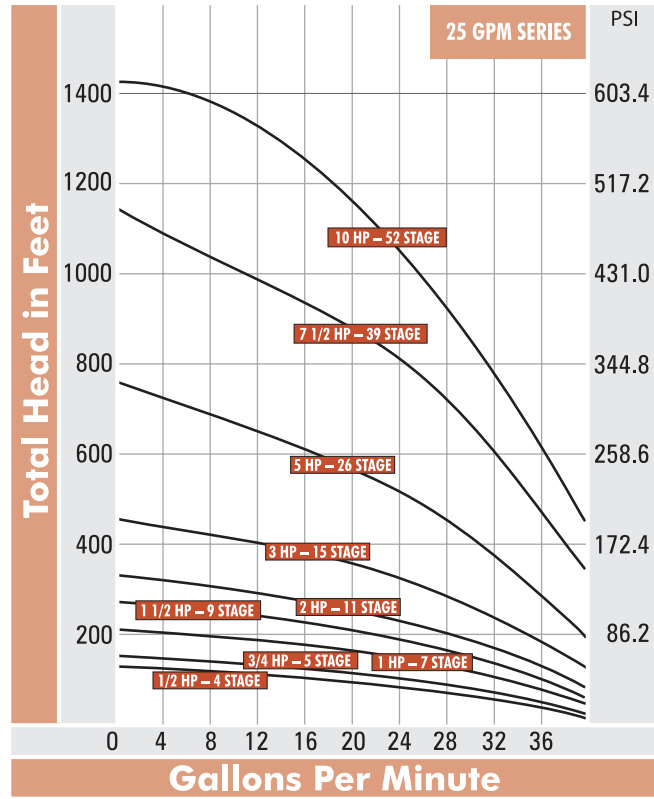

**Specifications** Pump End only. Submersible motors (p.72) must be selected and purchased separately.

HP	Diameter in	Discharge in	GPM	Approx. Length in	Weight lbs	Liquid Max Temp.	Model Number
1/2	3.9	1 1/2	25	9.9	5	104° F	WI6034883
3/4				10.7	5		WI6034884
1				12.4	6		WI6034885
1 1/2				14	7		WI6034886
2				15.6	8		WI6034887
3				19	9		WI6034888
5				28.3	14		WI6034890
7 1/2				39.1	25		WI6034891
10				65.5	47		WI6064252
1				14.6	8		WI6043290
1 1/2	16.2	9	WI6034893				
2	19.5	12	WI6034894				
3	22.8	14	WI6034895				
5	32.8	21	WI6034897				
7 1/2	49.3	32	WI6034899				
10	57.5	37	WI6034900				
15	83	57	WI2707578				
20	131.8	73	WI2707579				

## 4" Submersible Well Pumps 70 GPM Series

### Curves

HORSEPOWER RANGE: 2 – 10

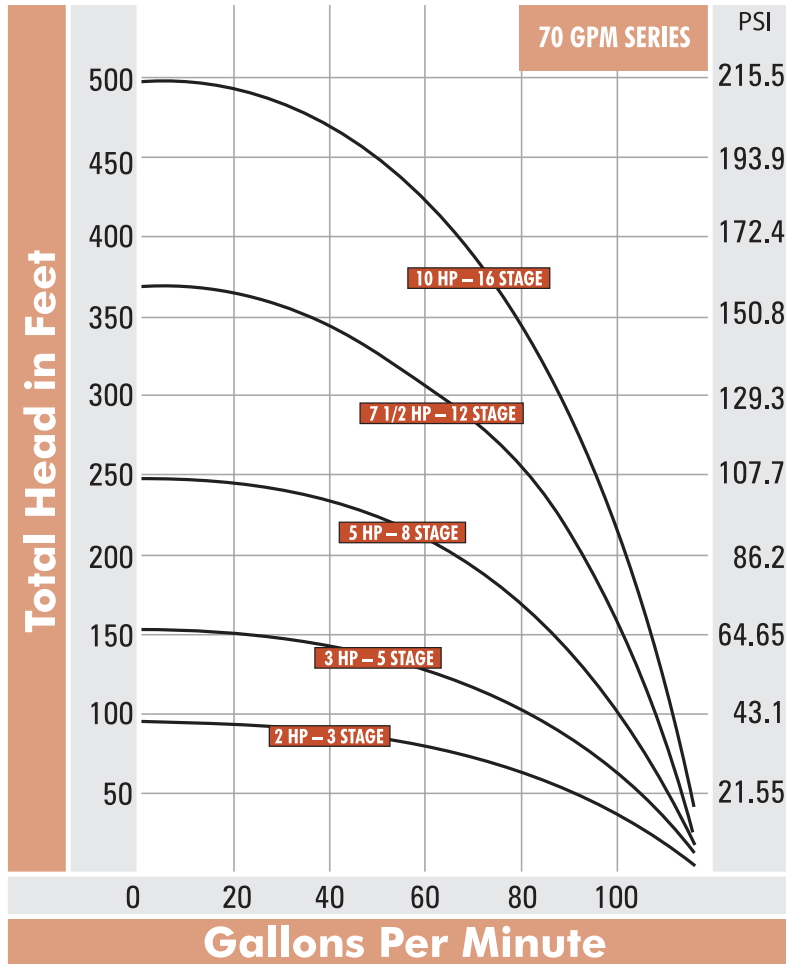

#### Did You Know?

Submersible motors must be positioned at least a 45° angle to avoid premature failure of thrust bearing.

SUBMERSIBLE

**Specifications** Pump End only. Submersible motors (p.72) must be selected and purchased separately.

HP	Diameter in	Discharge in	GPM	Approx. Length in	Weight lbs	Liquid Max Temp.	Model Number
2	3.9	2	70	14.8	8	104° F	WI6035168
3				19.9	12		WI6035169
5				27.6	16		WI6035170
7 1/2				37.8	21		WI6035171
10				48	27		WI6035172

## Submersible Motors



SUBMERSIBLE

HP	Volts	Amps	Thermal Protection	Service Factor	Length in	Weight lbs	Model Number
<b>2-Wire 4" Water Well Motors – 2 hots + ground (3 total wires)</b>							
1/2	115	12		1.60	9.53	18	FR2445049004S
1/2	230	6		1.60	9.53	18	FR2445059004S
3/4	230	8	Y	1.50	10.66	21	FR2445079004S
1	230	10.4		1.40	11.75	24	FR2445089003S
1 1/2	230	13.1		1.30	15.12	32	FR2443099004S
<b>3-Wire Single Phase With Ground Motors – 3 hots + ground (4 total wires)</b>							
1/2	115	12		1.60	9.53	18	FR2145049004S
1/2	230	6		1.60	9.53	18	FR2145059004S
3/4	230	8		1.50	10.66	21	FR2145079004S
1	230	10.4		1.40	11.75	24	FR2145089003S
1 1/2	230	11.5	Y	1.30	13.62	29	FR2243009203S
2	230	13.2		1.25	15.12	32	FR2243019204S
3	230	17		1.15	19.06	52	FR2243022604
5	230	27.5		1.15	30.5	69	FR2243038602
<b>3-Wire 4" 3 Phase Motors – 3 hots + ground (4 total wires)</b>							
1/2	230	2.9		1.30	9.53	29	FR2345119204S
1/2	460	1.5		1.30	9.53	29	FR2345213116S
2	230	8.1		1.25	13.62	32	FR2343159204S
2	460	4.1		1.25	13.62	32	FR2343259404S
3	230	10.9	Y	1.15	16.06	43	FR2343159204S
3	460	5.5		1.15	16.06	43	FR2343262604
5	230	17.8		1.15	23.2	53	FR2343278602
5	460	8.9		1.15	23.2	53	FR2343278602G



### Did You Know?

3-wire submersible pump motors require a control box, while 2-wire submersible pump motors do not.



### Did You Know?

How to count the wires:  
 2 wires = 2 wires + a ground  
 3 wires = 3 wires + a ground

## Single Phase Control Boxes



Approx. Weight lbs	Volts	HP	Model Number
3	115	1/2	FW127185
3		1/2	FW127189
3		3/4	FW127197
3		1	FW126319
6		1 1/2	FW133589
6	230	2	FW126321
7		3	FW126322
12		5	FW135269
8		7.5	BES14638
12		7.5	FW135271
8		10	BES19910
12		10	FW135273

## Submersible Constant Pressure Systems

"City-like" water pressure for rural water systems in one complete package.

### System includes:

- Controller with advance electronics – Air-cooled NEMA 1 enclosure, adjusts 25 to 80 PSI constant pressure and includes pressure switch.
- Factory specified pump end for optimal performance and efficiency.
- Stainless water-lubricated motor – Performance matched for long life, specified to avoid overload.
- Small 4.8 or 14.0 gallon tank – Saves space and money. Properly sized and pre-charged to 35 PSI for use with this system.

### Built-in protection & diagnostics for:

- Surge Protection
- Underload – low water conditions
- Undervoltage
- Short Circuit
- Overheated Controller – with auto compensation feature
- Locked Pump – with auto reverse function

SUBMERSIBLE

## Submersible Constant Pressure Systems

### Features:

- Easy Installation
- Increases flow as demand increases
- Adjustable constant pressure
- Automatic pump and motor protection
- Smart Reset technology

### Residential Water Systems

- "City-like" water pressure
- Smaller tank saves space

### Geothermal Systems

- No need for large buried tanks
- Eliminates pressure cycling

### Lawn Irrigation Systems

- Handles varying water demand by zone
- Eliminates need for separate system

### Water Treatment Systems

- More efficient back flushing
- No need for multiple pumps

### Applications:

### Curves

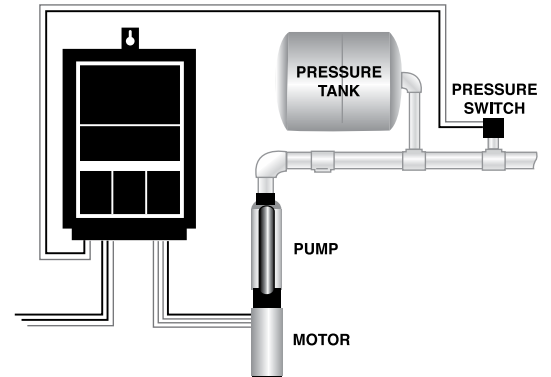
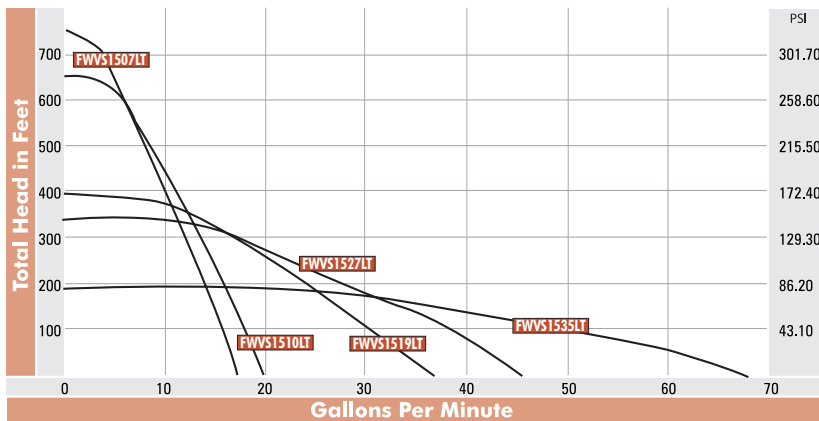

### Specifications

Pump Diameter in*	Total Length in	Discharge Size in**	Tank Pressure	Pressure Preset at 50 psi	Controller Enclosure	Amps (RMS)		Voltage Single Phase	Model Number
						Output	Input		
3.88	31.2	1 1/4	14	25-80 Adjustable	Nema 3R	5.9	11	200-250	FWWS1507LT
	30.7	1 1/4	14			5.9	11		FWWS1510LT
	28.8	1 1/4	14			5.9	11		FWWS1519LT
	27.1	1 1/4	14			5.9	11		FWWS1527LT
	23.6	2	14			5.9	11		FWWS1535LT

\*Diameter includes Cable Guard

\*\*2" discharge pumps do not include interval check valve

Other sizes available upon request.

## Submersible Well Pump Sleeves

### Flow sleeves are recommended for wells, large diameter, uncased, top feeding & screened sections

Submersible motors are designed to operate primarily in the vertical, shaft-up position and with a cooling flow of water over the motor. If the pump installation does not provide the minimum flow, a flow inducer sleeve (flow sleeve) must be used.

#### Conditions requiring a flow sleeve:

- Well diameter is too large to meet flow requirements.
- Pump is in an open body of water.
- Pump is in a rock well or below the well casing.
- The well is top-feeding.
- Pump is set in or below screens or perforations.

#### Flow Sleeve Features:

- Range from 7 to 70 GPM of water flow between flow sleeve and submersible motor
- Rubber motor-centering bumpers for even water flow along motor
- Made from corrosion resistant plastic for clean water applications
- Stainless steel fasteners
- Easy installation of industry-proven, long-lasting 4" submersible pump and motor



#### Did You Know?

If the flow of water is coming from above the pump, then a flow sleeve must be added for motor cooling. A flow sleeve is always required in an open body of water.

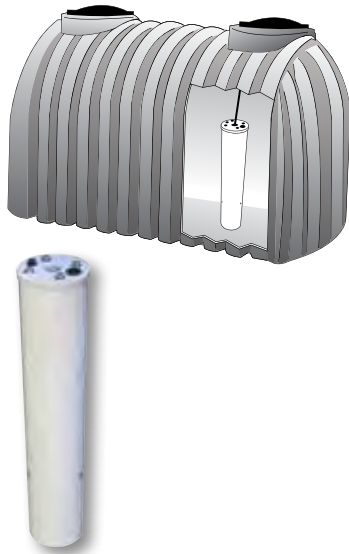

Approx. Weight lbs	Approx. Dimensions in	Discharge Size in	Pump & Motor Total Length in	Model Number
9	33	1	20 – 30	SA530100SO
		1 1/4		SA530125SO
		2		SA530200SO
11	43	1	28 – 40	SA540100SO
		1 1/4		SA540125SO
		2		SA540200SO
14	53	1	38 – 50	SA550100SO
		1 1/4		SA550125SO
		2		SA550200SO
17	63	1	48 – 60	SA560100SO
		1 1/4		SA560125SO
		2		SA560200SO

## Submersible Well Pump Flow Sleeve & Stand

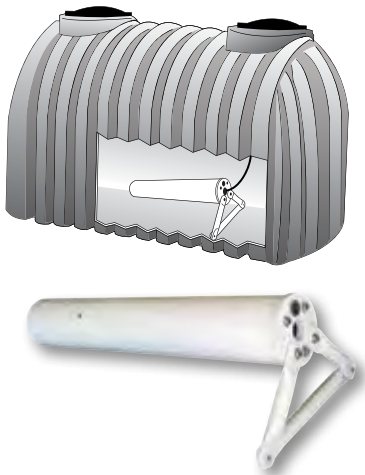

Approx. Weight lbs	Approx. Dimensions in	Discharge Size in	Pump & Motor Total Length in	Model Number
11	33 x 12	1	20 – 30	SA530100WS
		1 1/4		SA530125WS
		2		SA530200WS
13	45 x 17	1	28 – 40	SA540100WS
		1 1/4		SA540125WS
		2		SA540200WS
16	55 x 19	1	38 – 50	SA550100WS
		1 1/4		SA550125WS
		2		SA550200WS
19	65 x 27	1	48 – 60	SA560100WS
		1 1/4		SA560125WS
		2		SA560200WS

Munro carries a wide variety of industrial pumps. While not often used by the irrigation industry, if you come across a job that requires these specialty pumps, remember, Munro has it! For more information on these items and more, visit us online at [munropump.com](http://munropump.com).

## Munro FTP/FTPS/FTPA Series High Volume Slurry and Sand Pumps

These pumps are built using a 4-pole motor to handle high particulate fluid. Cast iron construction extends the life of the pump by preventing premature wear and failure due to abrasive materials found in mining, aggregate, and construction applications.

### Applications:

- FTP pumps open intake makes them ideal for use in mine and quarry dewatering, dredging, open pit coal and ore slurries, sewage treatment plants, and steel mills.
- FTPS/FTPA pumps come with a screen (S) and an optional agitator (A) for use in mine site dewatering, dredging, waste water recycling, slurry or waste treatment on constructions sites, and waste treatment on cement plants.

### Transfer pumps

These gasoline engine driven pumps are constructed with a rugged cast iron casing, cast iron impeller, Viton and stainless mechanical seal, and are powered by either a 5 or 8 hp engine.

**Applications:** agriculture and contractor transfer, booster, sprayer and sprinkler applications.

### Out-of-Pond Pumps

This end-suction centrifugal pump is designed for use on the outer perimeter of a pond (or other water source). The pumps provide energy-efficient, continuous operation for lower power consumption. For added protection and weather resistance, motors are enclosed and rated for indoor/outdoor use.

**Applications:** Irrigation, drawing water from lakes, ponds, cisterns, streams and shallow wells.

### Hot Water Circulating Pumps

This is a hydronic circulator used to circulate a fluid within a closed system.

**Applications:** Circulating water or ethylene glycol in closed hydronic, boiler or solar heating systems.

### Jet Pumps

The Munro MUSW Series Shallow Well Jet Pumps deliver up to 13 gpm at city water pressure. These sturdy, economical pumps feature a square flanged permanent split capacitor and switchless, double ball bearing motor. The impeller and diffuser are constructed of high impact thermo-plastic for greater efficiency. The MUSW also includes a long-life pressure switch to help automate a well system.

**Applications:** Booster, residential water systems, clean water systems.

### Chemical Feed Pumps

These pumps are used to move a precise amount of a liquid into a system over a period of time.

**Applications:** Fertilizer or pesticide delivery

### Also Available:

- Hydrostatic Test Pumps – Hand or Powered
- Fuel Transfer Pumps
- Standard Duty Metallic Diaphragm Pumps
- Heavy Duty Flapper Diaphragm Pumps
- Diaphragm Pumps
- Cistern Pumps – Classic style, Hand Operated
- Hand Pump Primers
- Vertical Turbine Pumps



### Did You Know?

We have Eccentric Suction fittings on p. 150

SLURRY  
Pumps



TRANSFER  
Pumps



CHEMICAL FEED  
Pumps



JET  
Pumps



OUT-OF-POND  
Pumps



HOT WATER  
CIRCULATING  
Pumps



## TYPICAL IRRIGATION PUMP CONTROLS

Normally a lawn controller is used to signal a start/stop cycle for an irrigation system. This controller signals valves to open or close to direct water flow into a particular pipeline, or zone, in an irrigation system. When a pump is present in the system, a lawn controller's start/stop signal is also received by a Pump Start Relay (PSR). This PSR interacts with the incoming signal and the power going to a pump, allowing it to follow the same start/stop pattern.

A lawn controller is the most common way to signal a pump start relay. Other signal devices may also be used, including float switches, pressure switches, and toggle switches.

Each start/stop signal will send a specific signal voltage. Most lawn controllers emit 24v signals, while other signal devices often send higher voltage signals. The signal receiver, or coil, of the electrical contactor inside the PSR must match the signal voltage so it will engage the contactor. Once engaged, power is allowed to flow from the breaker box to the pump motor. When the lawn controller no longer sends the signal, the contactor is no longer engaged and the power flow to the pump motor is stopped.

Pump start controls range from a very simple pump start relay to devices that also offer pump protection to shut the pump down before it is damaged. More complex controls may start and stop multiple pumps, accept signals from multiple devices, or maintain constant pressure.

At Munro, pump start controls and protection is one of our passions and expertise. We have developed innovative products and, when your requirements are unique, we will work with you to create custom solutions.

## MUNRO PUMP CONTROLS ARE EXCEPTIONAL

**Safe Reduced External Amperage** – By the end of 2021, all control power leaving a Munro box will be low amperage rated so that risk to people or pets is minimized. Look for the 'Safe 24v Signal' designation.

**UL Listed** – Every single component used is tested, approved and certified by Underwriter's Laboratory to assure safe operation.

### Built tough – UL-50 Type 3R

UL-50 Type 3R control enclosures are designed to provide protection – available in both Stainless Steel and Powder Coated Steel – to last in all environments.

### Easy to install and maintain

Color coded wire leads make wiring Munro boxes a simple process.



### Did You Know?

Not sure which control box you need? Check out our new pump control selection tool on p.199.

Typical Wiring for Basic Irrigation System Controls

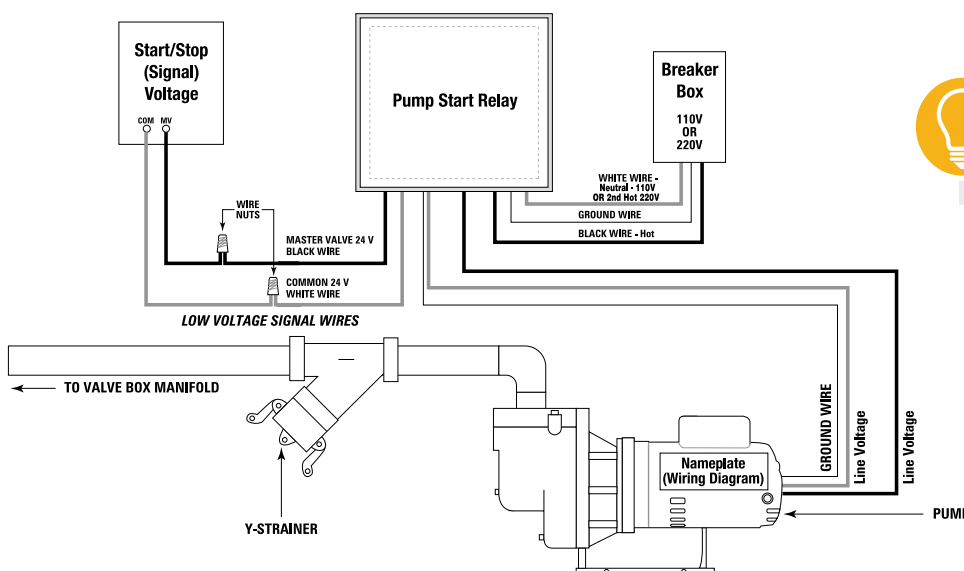

### Did You Know?

The SmartBox by Munro was designed in 1986! That's over 30 years of pump protection!

NOTE: Pump controls must be compatible with the hp of the pump.

# Munro StartBox



### StartBox™ – Standard (The Old Stand-by)

This flexible, easy-to-install pump start relay provides “pilot-duty” operation for all electrically driven pump equipment. No need to wonder which relay to use, the Munro StartBox has a 40 amp relay to work equally well with single phase 3/4 hp to 5 hp.\* For use with controllers with a .36 amp signal or stronger.

- Works with any residential turf irrigation pump – available in 24v, 110v and 220v coils
- Color-coded wiring – makes hook up a breeze
- UL and CUL listed relay and enclosure – safe and reliable

\*For three phase and larger hp units – see Custom Box section, pages 95-99.

### CONSTRUCTION

- UL and CUL listed relay
- UL-50 Type 3R listed enclosure – approved for outdoor use, available in stainless steel or powder coated blue

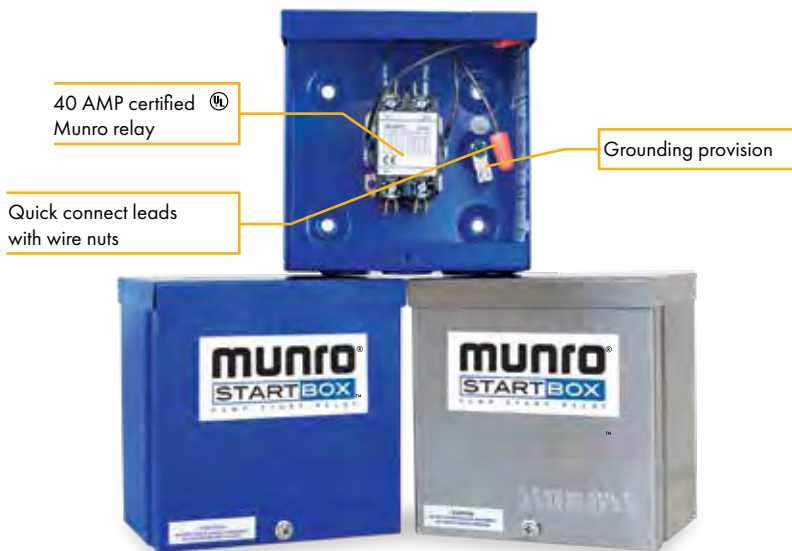

### Did You Know?

External components, like float switches and sensors wired at full 110v or 220v line voltage can pose a danger to people and pets.

Look for Munro's safe 24v output options to reduce voltage threat to 24v.

Electrical Rating	Largest Motor	Short Circuit Rating
120V – 24FLA	2HP – 120V	120V – 5KA
240V – 28FLA	5HP – 240V	240V – 5KA

### Specifications

Control Voltage	Enclosure Color	LP Dimensions In.	Hertz	Inrush/Run	Phase	Safe 24v Output	Model Number
24	BLUE	6x6x4				✓	MPSR24
	STAINLESS					✓	MPSR24S
110	BLUE	8x8x4	60	360MA/270MA	1	✓	MPSR110*
	STAINLESS						MPSR110S*
	BLUE	✓				MPSR110A	
	STAINLESS	✓				MPSR110AS	
220	BLUE	6x6x4					MPSR220*
	STAINLESS	8x8x4					MPSR220S*
	BLUE						✓
	STAINLESS					✓	MPSR220AS

\*NOTE: Munro does not recommend using this item with a line voltage external device. Use items marked “Safe 24v” for low voltage option.

# Munro StartBox – Low Amp/2-Wire Decoder Compatible



### StartBox™ – Reduced Incoming Amperage

This flexible, easy-to-install pump start relay provides “pilot-duty” operation for all electrically driven pump equipment and works with any reliable brand of 24v lawn controller – including those that provide less than .35 amps for pump start. Voltage specific – 110v or 220v – to match line voltage of the pump.

- Single unit StartBox eliminates the need to install secondary booster boxes when used with a decoder
- Accepts a low amperage start signal from controller to provide all of the benefits of the standard StartBox, even though signal amperage is reduced

### CONSTRUCTION

- Dimensions – 6”x6”x4”
- UL and CUL listed relay
- UL-50 Type 3R listed enclosure – approved for outdoor use, available in stainless steel or powder coated blue



CONTROLS



### Specifications

Pump Voltage	Control Voltage	Enclosure Color	Electrical Rating	Largest Motor	Hertz	Phase	Model Number
110	24v	BLUE	120V – 24FLA 240V – 28FLA	2HP – 120V 5HP – 240V	60	1	MPSR242W11
110		STAINLESS					MPSR242W11S
220		BLUE					MPSR242W22
220		STAINLESS					MPSR242W22S

\*Lawn controller signal only – no external components apply.



### Did You Know?

All Munro control boxes are also available in 3 phase! See pages 86-97 for custom options.

# Munro StartBox – Thermal Protection



## StartBox™ – Thermal Protection

This StartBox variation protects the pump motor from damage due to over amping while still performing all the basic functions of the standard pump start relay.

- Provides the pump motor with thermal overload protection, even when the motor itself does not
- Overload can be reset manually or automatically (default), upon cool down
- For use with single phase motors, but three phase option also available
- Reduced incoming amperage option available

## CONSTRUCTION

- Quick-connect terminals
- UL listed relay
- UL-50 Type 3R listed enclosure – approved for outdoor use, available in stainless steel or powder coated blue\*

## Thermal Protection

- Provides the pump motor with thermal overload protection, even when the motor does not.
- Thermal protection and pump start function are both provided within one enclosure.
- Thermal protection auto-resets upon cool-down.
- Available for pumps 3 hp and above.

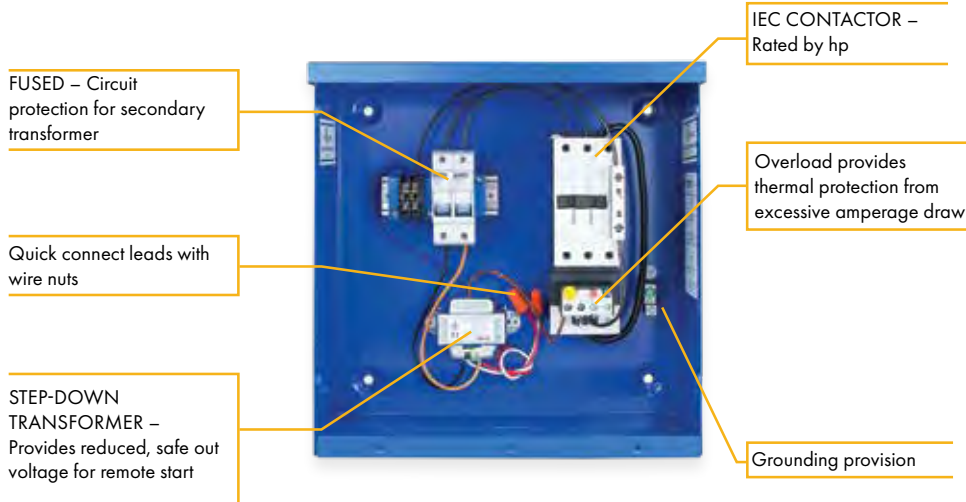

## Specifications

Line Voltage	Control Voltage	HP	Amp Range	Dimensions in	Hertz	Safe 24v Output	Model Number*
220	24	3	17	12X12X6	60	✓	MPSR24V3
220	220	3				✓	MPSR220V3
220	24	5	28			✓	MPSR24V5
220	220	5				✓	MPSR220V5
220	24	7 1/2	40			✓	MPSR24V75
220	220	7 1/2				✓	MPSR220V75
220	24	10	50			✓	MPSR24V10
220	220	10				✓	MPSR220V10

\* Add "S" (Stainless) to end of part number.

National electrical code (NEC) states all motors will be thermally protected from excessive "amperage draw."

Motors 2 hp and under are supplied with thermal protection from the motor manufacturer. For motors over 2 hp, StartBox with thermal protection is recommended.

CONTROLS

## Munro SmartBox



### SmartBox™ – Standard (The Old Stand-by)

A great option for pump start and pump protection in one, the Munro SmartBox includes pressure and temperature sensors that monitor the pump's performance, proactively shutting the pump down in deadhead and run-dry conditions.

- **“Run-dry”** = pump runs without water coming into the suction side. Symptoms include: the pump runs but does not deliver water, hot motor, inconsistent water flow/surges, water puddles under the pump.
- **“Deadhead”** = pump is operating, but the water doesn't flow to the sprinklers. The common causes of deadhead is valve(s) not being open. Symptoms include: unusually hot pump case super-heats water and leaves the pump and pipework subject to expansion or failure.

### CONSTRUCTION

- 40-amp relay to work equally well with any thermally protected, single phase 3/4 to 5 hp pump (Note: If your motor is not thermally protected, see option on page 89)
- Dimensions – 8" x 8" x 4"
- Available in 24v, 110v, 220v coils
- Quick connect terminals
- UL listed relay
- UL-50 Type 3R listed enclosure - approved for outdoor use, available in stainless steel or powder coated blue



**Did You Know?**  
Standard Smart Boxes offer an optional 24v circuit to energize an external master valve.



Temperature Switch  
Included as noted

Pressure Sensor and  
Boot Included



Electrical Rating	Largest Motor	Short Circuit Rating
120V – 24FLA	2HP – 120V	120V – 5KA
240V – 28FLA	5HP – 240V	240V – 5KA

### Specifications

Signal Voltage	Enclosure Color	Hertz	Line Voltage	Phase	Safe 24v Signal	20 PSI Pressure Sensor	130 °F Temp Sensor	Model Number
24	BLUE	60	110-240	1	✓	✓	--	MPLC24
	STAINLESS				✓	✓	--	MPLC24S
	BLUE				✓	✓	✓	MPLC24T
	STAINLESS				✓	✓	✓	MPLC24TS
110	BLUE				✓	✓	✓	MPLC110T
	STAINLESS				✓	✓	✓	MPLC110TS
220	BLUE				✓	✓	✓	MPLC220T
	STAINLESS				✓	✓	✓	MPLC220TS

For three phase and larger hp units – see Custom Box section, p.95-99.

# Munro SmartBox – Low Amp/2-Wire Decoder Compatible



### SmartBox – Reduced Incoming Amperage

A great option for pump start and protection in one, the Munro SmartBox includes a preset pressure sensor that alerts the control system of potential pump damage due to loss of prime or run-dry, and will work with all reliable lawn controllers. Voltage specific – 110v or 220v – to match line voltage to your pump.

- Accepts a low amperage start/stop signal – to provide all of the benefits of the standard SmartBox, including loss of prime and run-dry protection, even when signal amperage is reduced.
- Works with any brand, any style of 24v lawn controller.
- For use with lawn controllers that provide less than .35 amps for pump start signaling.
- Run-dry and dead-head protection



### CONSTRUCTION

- Dimensions – 8”x8”x4”
- Color coded wiring
- UL listed relay
- UL-50 Type 3R listed enclosure – approved for outdoor use, available in stainless steel or powder coated blue



**Did You Know?**  
Works with any brand, any style of 24v irrigation controller

CONTROLS

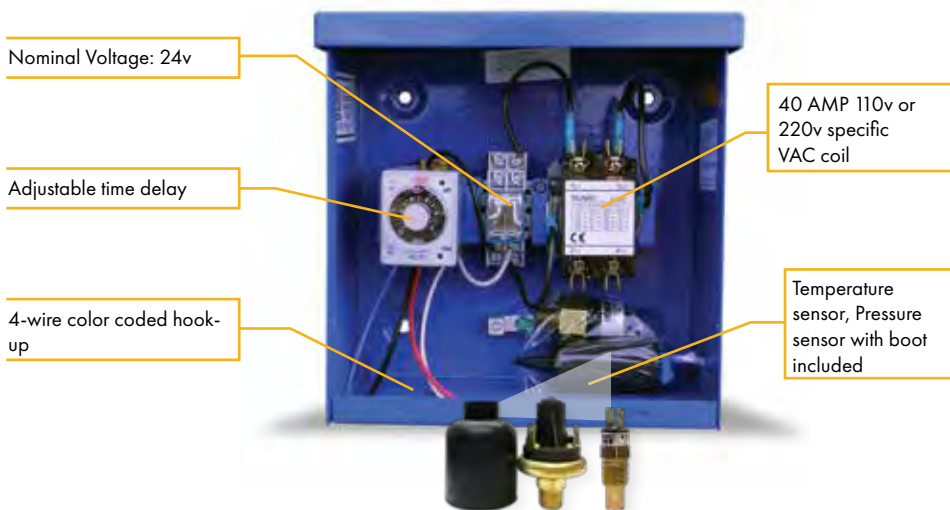

Electrical Rating	Largest Motor
120V – 24FLA	120V – 2HP
240V – 28FLA	240V – 5HP

### Specifications

Signal Voltage	Enclosure Color	Hertz	Line Voltage	Phase	Safe 24v Signal	20 PSI Pressure Sensor	130° Temp Sensor	Model Number
24	BLUE	60	110 only	1	NA*	✓	✓	MPLC242W11T
	STAINLESS					✓	✓	MPLC242W11TS
	BLUE		220 only			✓	✓	MPLC242W22T
	STAINLESS					✓	✓	MPLC242W22TS

\* Lawn controller signal only – no external components apply.

# Munro SmartBox – Thermal Protection



## SmartBox – Thermal Protection

This SmartBox variation not only protects the pump from damage due to run-dry or loss of prime, it also protects the pump from damage due to over amping the motor.

- Provides the pump motor with thermal overload protection, even when the motor itself does not.
- Overload can be reset manually or automatically (default) upon cool down
- For use with single phase motors, but three phase option also available
- Reduced incoming amperage option available

## CONSTRUCTION

- Quick connect terminals
- UL listed contactors and overloads
- UL-50 Type 3R listed enclosure – approved for outdoor use, available in stainless steel or powder coated blue\*



**Did You Know?**  
All Munro pump controls have safe 24v external power.

CONTROLS

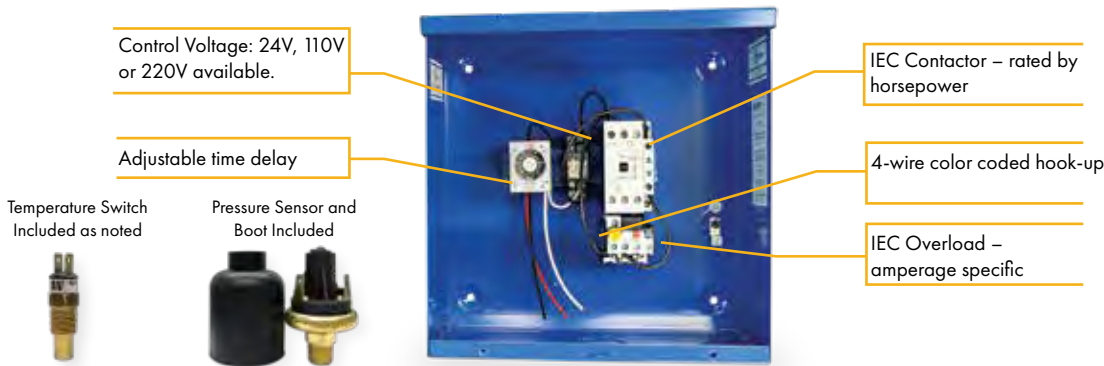

## Thermal Protection

- Provides the pump motor with thermal overload protection, even when the motor doesn't.
- Thermal protection and pump protection are both provided within one enclosure.
- Thermal protection auto-resets upon cool-down.
- Available for pumps 3 hp and above.

## Specifications

Signal Voltage	Amp Range	Dimensions in.	Approx. HP	Hertz	Line Voltage	Phase	Safe 24v Signal	20 PSI Pressure Sensor	130 °F Temp Sensor	Model Number*	
24 220	16-24	12x12x6	3	60	240	1	✓	✓	✓	MPLC243T	
								✓	✓	✓	MPLC2203AT
24 220	24-32		5				✓	✓	✓	MPLC245T	
							✓	✓	✓	MPLC2205AT	
24 220	34-50		7.5				✓	✓	✓	MPLC2475T	
							✓	✓	✓	MPLC22075AT	
24 220	50-65	10				✓	✓	✓	MPLC2410T		
							✓	✓	✓	MPLC22010AT	

\* Add "S" (Stainless), to end of part number.



## Munro BrainBox – Standard



### BrainBox Rainwater Harvest Control Box – Standard

Using a series of float control switches, the BrainBox monitors the water level in a holding tank. If there is sufficient held water to feed the pump when the start signal is received, the pump will pull the water from the tank. If there is not enough water available, the BrainBox opens an alternate water source – domestic or secondary water supply. This secondary source can be plumbed into the system directly or can be used to maintain a minimum level in the holding tank. Available for use with 110v and 220v line voltage, single phase\*.



#### Sensor and control features

- A preset pressure sensor alerts the control system of potential pump damage due to loss of prime or run-dry caused by a clogged filter.
- A temperature sensor offers additional protection for pump and pipework in the case of dead head or a solenoid valve not opening.

#### CONSTRUCTION

- Dimensions – 12”x12”x6”
- Color-coded wiring
- UL-50 Type 3R listed enclosure – approved for outdoor use, available in stainless steel or powder coated blue\*\*

#### INTERNAL COMPONENTS

- UL listed
- Electrical Rating: 120v/240v – 24/28FLA
- Largest motor: 110v – 2 hp  
220v – 5 hp

#### EXTERNAL DEVICES

- Low pressure sensor – fixed at 20 psi
- High temperature sensor – fixed at 130°
- Float control – 13 amp @ 120/240 VAC with 16 AWG cord

#### Specifications

Signal Voltage	Enclosure Color	No. of Floats	Thermal Protection	Max Horsepower	Max Amps	Hertz	Line Voltage	Phase	Safe 24v Output	Model Number
24	BLUE STAINLESS	1	NO	2	240v - 28 FLA	60	110-220	1	√ √	MBRB241 MBRB241S
	BLUE STAINLESS	2	NO	2		60		1	√ √	MBRB24S MBRB242S

Use custom control worksheet on p. 99 to specify units larger than 5 hp.



### BrainBox Rainwater Harvest Control Box – Thermal Protection

This BrainBox variation not only runs your Rainwater Harvest system with all the features of the standard BrainBox, it protects the pump from damage due to over-amping the pump motor.

- Provides the pump motor with thermal overload protection, even when the motor itself does not
- For use with single phase motors, but three phase option also available

#### Thermal Protection

- Provides the pump motor with thermal overload protection, even when the motor doesn't.
- Thermal protection and pump protection are both provided within one enclosure.
- Thermal protection auto-resets upon cool-down.
- Available for pumps 3 hp and above.

#### Specifications

Signal Voltage	Enclosure Color	No. of Floats	Thermal Protection	Max Horsepower	Max Amps	Hertz	Line Voltage	Phase	Safe 24v Output	Model Number
24	BLUE STAINLESS	1	NO	2	240v - 28 FLA	60	110-220	1	√ √	MBRB241 MBRB241S
	BLUE STAINLESS	2	NO	2		60		1	√ √	MBRB24S MBRB242S

Use custom control worksheet on p. 99 to specify units larger than 5 hp.

# Munro BrainBox Low Amp/2 Wire Compatible



## BrainBox Rainwater Harvest Control Box – 2-Wire

This BrainBox variation, while monitoring your Rainwater Harvest System, is compatible with the signal of a 2-wire system or low amperage controller.

- Single unit BrainBox eliminates the need to install secondary booster boxes when used with a decoder system
- Accepts a low amperage start signal from controller to provide all of the benefits of the standard BrainBox

### SPECIFICATIONS

- Accepts a low amperage start/stop signal – to provide all of the benefits of the standard BrainBox, including loss of prime or run-dry protection, and safe reduced voltage float control, even when signal amperage is reduced.
- Compatible 2-wire system – Works with any brand, any style of 24v lawn controller.
- For use with lawn controllers that provide less than .35 amps for pump start signaling.



CONTROLS

### Sensor and control features

- A preset pressure sensor alerts the control system of potential pump damage due to loss of prime or run-dry caused by a clogged filter.
- A temperature sensor offers additional protection for pump and pipework in the case of dead head or a solenoid valve not opening.
- Float controls are wired for 24v reduced external voltage, which is safer if people or pets come in contact with external sensors or switches.
- Available 3 hp and above

### CONSTRUCTION

- Dimensions – 12"x12"x6"
- Color-coded wiring
- UL-50 Type 3R listed enclosure – approved for outdoor use, available in stainless steel or powder coated blue\*\*

### INTERNAL COMPONENTS

- UL listed
- Electrical Rating: 120v/240v – 24/28FLA
- Largest motor: 110v – 2 hp  
220v – 5 hp

### EXTERNAL DEVICES

- Low pressure sensor – fixed at 20 psi
- High temperature sensor – fixed at 130°
- Float control – 13 amp @ 120/240 VAC with 16 AWG cord

### Specifications

Signal Voltage	Enclosure Color	No. of Floats	Low In-coming Amp Compatible	Largest Motor	Hertz	Line Voltage	Phase	Safe 24v Signal	Model Number
PARTIAL TANK UTILIZATION									
24	BLUE	1	YES	2HP	60	110	1	N/A*	MBRB242W11
	STAINLESS					220			MBRB242W11S
24	BLUE	2	YES	2HP	60	110	1	N/A*	MBRB242W22
	STAINLESS					220			MBRB242W22S
FULL TANK UTILIZATION									
24	BLUE	2	YES	2HP	60	110	1	✓	MBRBMAX242WA11
	STAINLESS							✓	MBRBMAX242WA11S
	BLUE							✓	MBRBMAX242WA22
	STAINLESS							✓	MBRBMAX242WA22S

Three phase options available through custom section, p. 95-99.  
\* Lawn controller signal only – no external components apply

# Munro Multi-Signal/One Pump Control Box



Whether sharing a pump between neighbors or sectioning a large property, the Munro Multi-Signal Control Box receives start signals from several different lawn controllers and allows one pump to run. The box isolates each run signal to protect unwanted power surges from damaging the other controllers.

- Available in two levels – 2-3 controllers or 4-6 controllers
- Save time and money buying standard configured control panels – if you have 5 controllers purchase the 4-6 level and use 5 of the connections
- Low Incoming Amperage Compatible – will work with any lawn controller
- SAFE – all voltages leaving the box are low, 24v
- Available with and without run-dry and high temperature pump protection
- Voltage specific – based on the pump requirement, 110v or 220v

### CONSTRUCTION

- UL-50 Type 3R listed enclosure
- Quick connect terminals



CONTROLS

Temperature Switch  
Included as noted



Pressure Sensor and  
Boot Included



Fused circuit protection

Controller isolation  
1 2 3

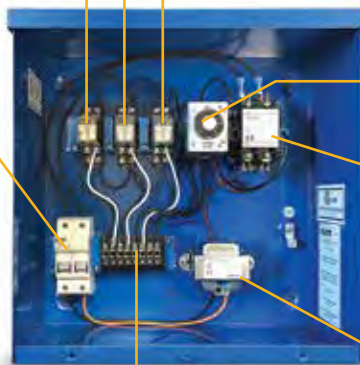

Adjustable time delay  
(MPLC only)

40 AMP certified  
Munro relay

24V transformer

(MPLC242W2-3XC22T shown)

Easy connect terminal strip

### Specifications

Box Type	Pump Voltage	Enclosure Color	Electrical Rating	Largest Motor hp	Phase	No. of Controllers	Safe 24v Signal	20 psi Pressure Sensor	130 °F Temp Sensor	Model Number
StartBox	220	BLUE	39/56	3HP	1	2-3	✓	✓	✓	MPSR242W2-3XC22
		STAINLESS					✓	✓	✓	MPSR242W2-3XC22S
		BLUE	73/90/108			4-6	✓	✓	✓	MPSR242W4-6XC22
		STAINLESS					✓	✓	✓	MPSR242W4-6XC22S
SmartBox		BLUE	39/56			2-3	✓	✓	✓	MPLC242W2-3XC22T
		STAINLESS					✓	✓	✓	MPLC242W2-3XC22TS
		BLUE	73/90/108			4-6	✓	✓	✓	MPLC242W4-6XC22T
		STAINLESS					✓	✓	✓	MPLC242W4-6XC22TS

For 110v or more than 6 controllers, please contact Munro Technical Support.

# Munro Multi-Pump/One Signal Control Box

Need more than one pump to cover your property? Using the Munro Multi-Pump/One Signal Control Box lets you program your whole irrigation system in one central location while signaling multiple pumps to start and stop.



- Available for use with 2 pumps
- Low Incoming Amperage Compatible – will work with any lawn controller
- SAFE – all voltages leaving the box are low, 24v
- Available with and without run-dry and high temperature pump protection
- Voltage specific – based on the pump requirement, 110v or 220v
- Shuts down both pumps at once

### CONSTRUCTION

- Color-coded wiring
- UL-50 Type 3R listed enclosures
- Quick connect terminals



Temperature Switch  
Included as noted



Pressure Sensor and  
Boot Included

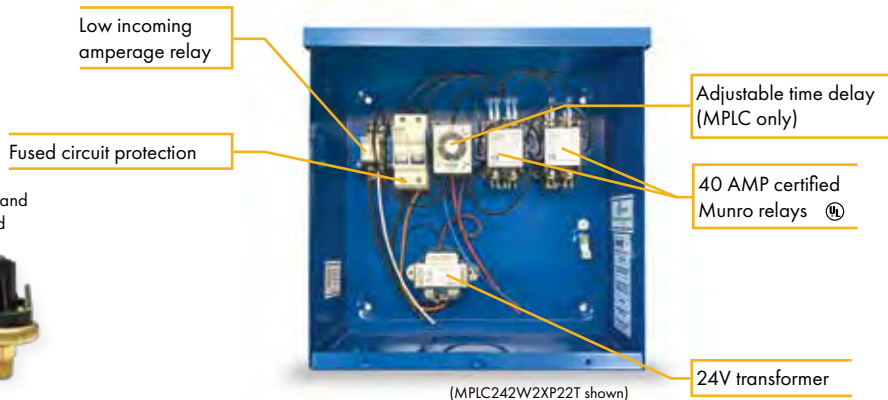

### Specifications

Box Type	Pump Voltage	Enclosure Color	Electrical Rating	Largest Motor hp	Phase	No. of Pumps	Safe 24v Signal	20 psi Pressure Sensor	130 °F Temp Sensor	Model Number
StartBox	220	BLUE	39/56	3HP	1	2	✓	✓	✓	MPSR242WX2P22
		STAINLESS					✓	✓	✓	MPSR242W2X2P2S
BLUE		✓					✓	✓	MPLC242W2X2P2T	
STAINLESS		✓					✓	✓	MPLC242W2X2P2TS	

For 110v, more than 2 pumps or other options, please contact Munro Technical Support.



### Did You Know?

Pump sequencing controls, predominately used in sewage applications, utilize an alternating relay. Contact Munro Tech Support if you need to sequence your pumps.

CONTROLS

# Munro TimeBox "Coaches Box"



### Push-Button-Start Controls

This unique control box is perfect for allowing coaches or visitors to access water to cool the field, keep dust down or sand cool in public spaces – such as athletic courts or fields. Users press a button to turn the water on for a pre-set amount of time (pumping water to sprinklers, misters, etc.). A pre-set lock-out time guards against flooding or overuse. The simple design powers a zone valve, eliminating the need for a separate irrigation controller.

### FEATURES AND BENEFITS

- Start and stop up to a 2HP pump and a 24 VAC Solenoid
- 24 volts .5 amps to power external valves – eliminating the need for a separate irrigation controller
- Time settings adjust from 1 second to 10 hours (factory set for 15 min. use and 1 hr. lock-out before re-start is allowed)
- Terminal block – makes hook up a breeze
- UL and CUL listed relay and enclosure – safe and reliable



CONTROLS

### CONSTRUCTION

- UL-50 Type 3R listed industrial stainless steel control panel – approved for outdoor use
- UL listed components
- Quick-connect terminals



### Did You Know?

TimeBox has many uses!

- Arena lighting
- Coaches switch
- Volleyball courts
- Horse arena

Industrial quality, easy-to-use push button operation

Quick-connect terminal block

Adjustable run time

Adjustable lock-out delay time



40 AMP certified Munro relay

Grounding provision

Lockable

### Specifications

Ship Weight lbs	Dimensions in	Hertz	Phase	Line Voltage	Relay Rating	Largest Motor	Solenoid Valve Start	Safe 24v Signal	Model Number
12	12x12x6	60	1	110	1 each/40 amp	2HP	1-24VAC	✓	MPSR110MYS AV
20	12x18x8				2 each/40 amp		2-24VAC	✓	MPSR1102MYS AV

Custom options available for 220 volt single phase or three phase and larger hp units. Contact Munro for more information.



### Did You Know?

Custom Push-Button-Start control boxes can be used with multiple pumps or to provide on-demand lighting in timed increments too!

# Munro Pressure Start Control Box



### CONSTRUCTION

- UL-50 Type 3R listed enclosure – available in stainless steel or powder coated blue\*
- UL listed components
- Quick-connect terminals



**Did You Know?**  
This box can be used on a Complete PRO II (p.17)

### StartBox – On Demand Controls

Grab your hose and water your plants or wash down the driveway, the pump will automatically run on your demand for water. No need for a pressure tank! On demand controls utilizes flow and pressure to detect water demand.

### FEATURES AND BENEFITS

- Start and stop up to a 2 hp pump
- Connect the pressure and flow switch to any pump discharge and the Pressure Start Control Box will turn the pump on and off
- Low pressure and dead-head protection
- Does not require a pressure tank
- Choose from 110 volt model or 220 volt model
- Low 24 volts to external switches

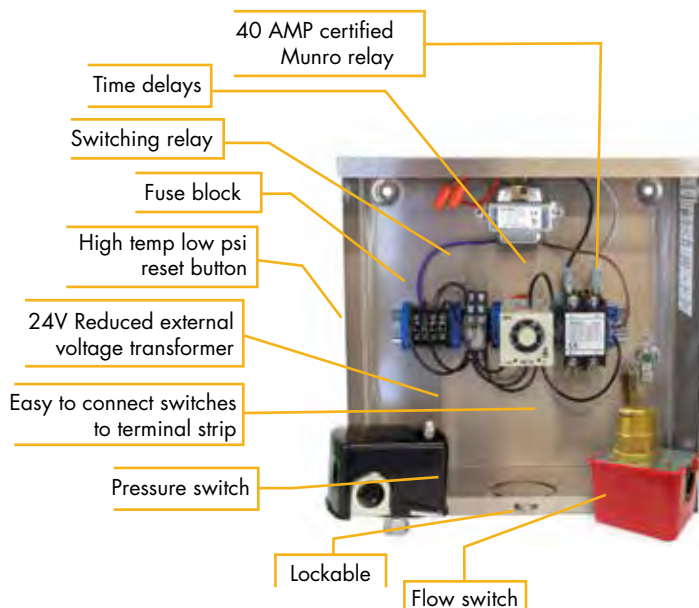

CONTROLS

### OPTIONS

- Pressure Start Control Box for larger hp motors available
- Higher pressure switches available
- Pump and fittings not included
- Constant pressure available with various system flow rates

NOTE: A water tight system is required. Air leaks in the system will cause pump to short cycle.



**Did You Know?**  
All pressure activated pump systems require a check valve on the discharge to avoid cycling.

### Specifications

Ship Weight lbs	Enclosure Size	Pressure Range	Flow Switch	Line Voltage	Pump HP Range	Pump Protection	Safe 24v Output	Model Number
20	12x12x6	20-90lb	1" - 2" pipe	110	3/4-2	N	✓	MPSR110AYF
120				N		✓	MPSR220AYF	
110				Y		✓	MPLC110AYFT	
120				Y		✓	MPLC220AYFT	

\* Add "S" (Stainless), to end of part number.

## Liquid Level Control Box



### Pump Up, Pump Down Control

The water level control box is a simple, cost effective control for applications when the water level is variable. The Munro water level control provides pump start operation when thermal overload protection is present. Used any place power can be interrupted, this control transforms all outbound voltage to a low, safe, 24v. Low external voltage is especially important when external sensors or switches are used, such as the float switch included with this control box.

### CONSTRUCTION

- Dimensions – 12"x12"x6"
- UL and CUL listed relay
- UL-50 Type 3R listed enclosure – approved for outdoor use, available in stainless steel or powder coated blue



CONTROLS

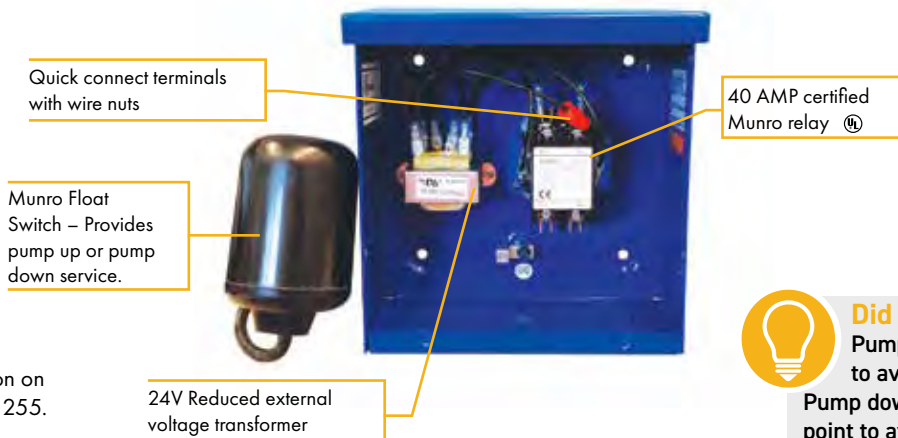

NOTE: See Resource Section on float switch usage on page 255.



### Did You Know?

Pump up = stops at the top to avoid overflowing.

Pump down = stops at a low point to avoid running dry.

### Specifications

Motor Voltage	Enclosure Color	Product Description	Largest Motor hp	Phase	Safe 24v Output	Dimensions in	Approx. Weight lbs	Model Number		
110	BLUE**	Pump Down Float	Up to 2HP	1	✓	12X12X6	12	MPSR110AD		
		Pump Up Float			✓		12	MPSR110AU		
Pump Down Float		Up to 5HP	✓		12		MPSR220AD			
Pump Up Float			✓		12		MPSR220AU			
220		Pump Down Float	3HP*		✓		9	MPSR220A3D		
		Pump Up Float			✓					
		Pump Down Float	5HP*		✓				9	MPSR220A5D
		Pump Up Float			✓					
		Pump Down Float	7.5HP*		✓				15	MPSR220A75D
		Pump Up Float			✓					
Pump Down Float		10HP*	✓		15		MPSR220A10D			
Pump Up Float			✓							

\* Includes motor thermal overload protection.  
 \*\* Add "S" (Stainless), to end of part number.

# Munro DamBox



### Water Feature Protection

The Munro DamBox provides the ultimate water feature pump protection by monitoring and responding to the water level inside a skimmer box.

The Problem: As filters become clogged, the water flow to the pump chamber may not be able to sustain the full capacity of the pump.

Without the Munro DamBox – An unprotected float switch will turn the pump off, allowing the water level to rise. With the higher water level the float switch will turn the pump on again. The pump pumps the chamber dry and turns back off. The damage cycle continues until an operator notices the problem or the pump fails.

With the Munro DamBox – The DamBox will lock-out the pump when the switch drops to indicate a water supply problem versus an incoming flow problem. Once the filter is cleared, a push of a button reactivates the pump protection.

### CONSTRUCTION

- Ground lug
- Quick-connect terminals
- UL listed relay
- UL-50 Type 3R listed enclosure – approved for outdoor use, available in stainless steel or powder coated blue

### FEATURES AND BENEFITS

- Transforms all outbound voltage to a low 24v, especially important when external sensors or switches are used.
- Designed for use with water features utilizing float switches.
- This option is safer if people or pets come in contact with external sensors or switches.



### Specifications

Voltage	Phase	Enclosure Color	Safe 24v Signal	Model Number
110	1	BLUE	✓	MPDB110B
110		STAINLESS STEEL	✓	MPDB110S
220		BLUE	✓	MPDB220B
220		STAINLESS STEEL	✓	MPDB220S

For three phase, see Munro Custom Controls on pages 95-99.

CONTROLS

## Munro DamBox

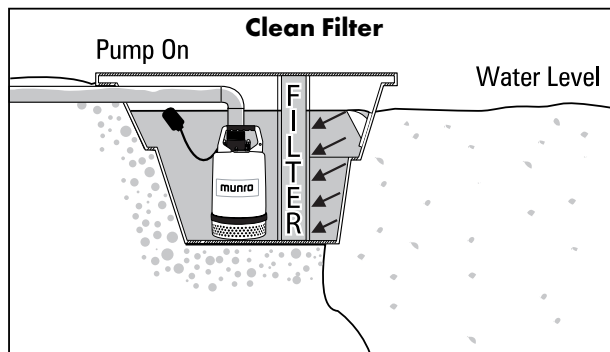
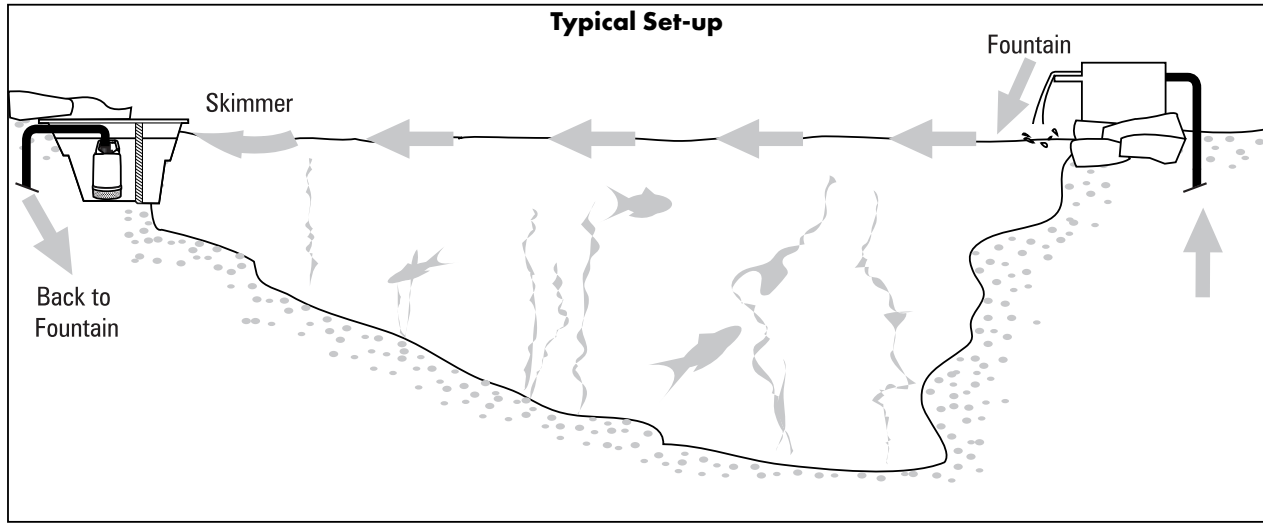

A clean filter will allow an equal amount of water to flow freely into the pump chamber as is pumped out of the chamber. The water level is consistent, which allows the pump to run at full capacity without interruption.

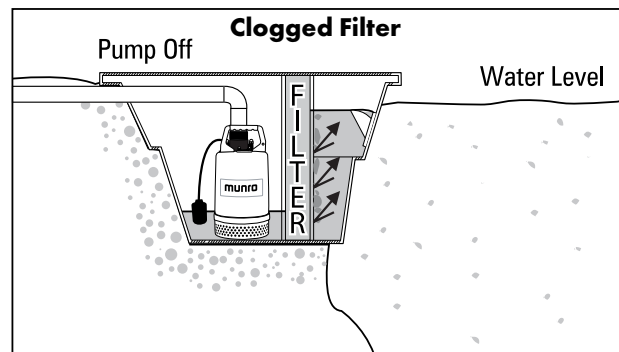

Clogged filters do not allow water to flow freely through the filter to the pump chamber. This “dam-ing” of the filter will create a run-dry condition for the pump where more water is pumped out than can enter the pump chamber. When water seeps through the filter the pump will short-cycle as water reaches positive pump conditions, and immediately shut off again when the water level drops.

### Thermal Protection

- Provides the pump motor with thermal overload protection, even when the motor doesn't.
- Thermal protection and pump protection are both provided within one enclosure.
- Thermal protection auto-resets upon cool-down.
- Available for pumps 3 hp and above.

# Munro Pump Control Panels

Housed in NEMA 3R rainproof and sleet-resistant enclosures, Munro Pump Control Panels feature combination starters with accessories and custom modifications to meet the needs of the irrigation market.

- Convenient straight-through wiring – top-line and bottom-load connections offer easily accessible pressure connections for line, load and control
- Overload relays with trip indication – Featuring bimetallic operation with ambient compensation and either manual or automatic reset
- Factory-wired starter and disconnect

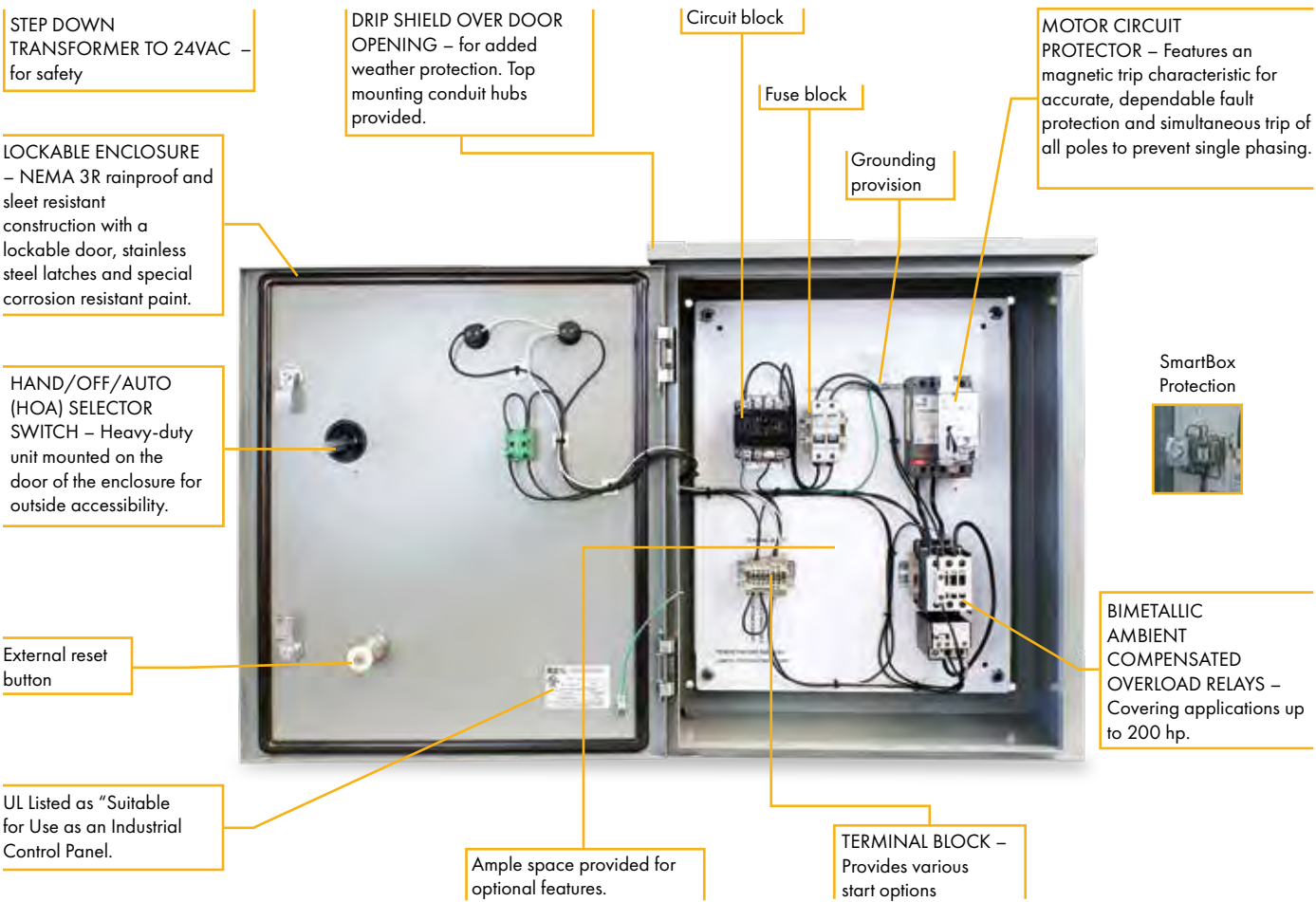

CONTROLS



## Munro Pump Control Panels

### Standard Features Include:

- Nema 3R enclosure
- Main circuit breaker
- IEC contactor
- Adjustable thermal overload protection
- External reset pushbutton
- Fused control circuit
- Hand-Off-Auto (HOA) selector switch
- Terminal block for connection of remote control device (low pressure switch)
- NOTE – “MPLC” model numbers designate the use of an optional SmartBox™ pump protection system.

### Overload Relay Features

Designed for 2,000,000 electrical operations and 20,000,000 mechanical operations through 20 hp at 460v. Solid state adjustable relays are available for single-class motors up to 10 hp at 230v, and for 3-phase motor applications from fractional horsepower.

- Single-phase and phase unbalance sensitivity for 3-phase units
- Ambient temperature compensated
- Adjustable trip current
- Overload trip indication
- Manual/Auto reset
- Electrically isolated NO-NC contacts

CONTROLS

### SmartBox™ Features

The Munro SmartBox option offers a preset pressure sensor (preset at 20psi) that alerts the control system of potential pump damage due to loss of prime or run-dry; and a preset temperature sensor (130°) that protects the system from over heating due to dead head.

### Specifications

Approximate Weight lbs	Voltage	Phase	HP	Max Amps	Size in	SmartBox Option	Model Number
43	230		3	17		√	MPLCCPG2103
			5	28		√	MPLCCPG2105
			7.5	40		√	MPLCCPG2107
			10	50		√	MPLCCPG2110
		3	3	9.6		√	MPLCCPG2303
			5	18.2		√	MPLCCPG2305
			7.5	22		√	MPLCCPG2307
			10	28		√	MPLCCPG2310
	480	3	15	42	√	MPLCCPG2315	
			20	54	√	MPLCCPG2320	
			3	4.8	√	MPLCCPG4303	
			5	7.6	√	MPLCCPG4305	
			7.5	11	√	MPLCCPG4307	
			10	14	√	MPLCCPG4310	
			15	21	√	MPLCCPG4315	
			20	27	√	MPLCCPG4320	

\* These boxes contain SmartBox low pressure protection  
Contact Munro for other panel sizes



#### Did You Know?

Panels with “Soft-Starts” are also available.











## Munro FloatControl



The Munro FloatControl is a direct acting, in-line control system for automatically controlling 1/2 hp and smaller pump motors, or used in conjunction with a pump start relay to accommodate larger hp motors.

The FloatControl can easily be adjusted to various pump up/down cycles by shortening or lengthening the cord length at the pivot point. The FloatControl is also omni-directional: the pumping differential is maintained in any horizontal position.

CONTROLS

### Technical Data:

- 13Amp at 120/240VAC with 16AWG cord
- Max Operating Temperature: 140 °F
- Protection Grade: IP68
- Float approved for drinking water application



**Did You Know?**  
We have a new Resource Section on float switch usage. Page 255

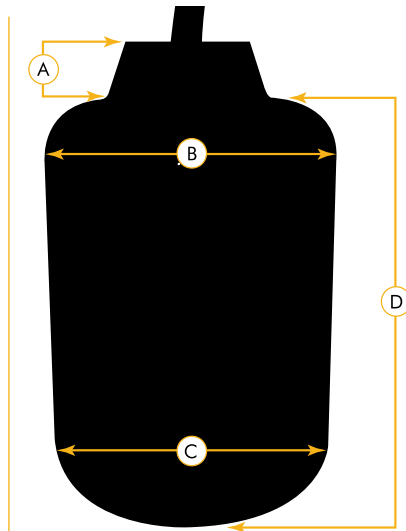

FloatControl Dimensions

A	B	C	D
.5"	2.75"	2.625"	3.95"

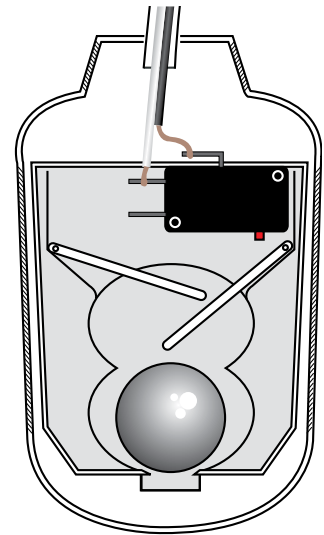

FloatControl Cutaway

Normally Open	Normally Closed	Weight Included	110V Piggy Back Ends	Quick Ends	16 Feet	33 Feet	55 Feet	Model Number
•		•		•	•			FC0246
•		•		•		•		FC0247
•		•		•			•	FC0248
	•	•		•	•			FC1246
	•	•		•		•		FC1247
	•	•		•			•	FC1248
•		•	•		•			FC0256
•		•	•			•		FC0257
•		•	•		•			FC0356

## Alarm with Float Control



### Indoor Alarm Features:

- Can be used with any UL listed switching mechanism rated 1 amps, 24 VAC minimum.
- Operates on low voltage and is isolated from the 120V power line to reduce the possibility of shock.
- UL Listed and CSA Certified.
- NEMA 1 panel features a red warning light, a green "power on" light, push-to-test alarm button, and a horn silence switch.

### Outdoor Alarm Features:

- NEMA 4X thermoplastic alarm panel. Horn and light warn of high or low liquid levels.
- Panel exterior features a large, red light specially designed noncorrosive horn, silence switch and alarm test switch.

Approx. Weight lbs	Voltage Alarm		Enclosure	Model Number
	Primary	Secondary		
5	120VAC	120VAC	NEMA 1 - Indoor	SRPW217115
4	120VAC	120VAC	NEMA 4X - Outdoor	SRPW217116

## DG Sumptrol Float Switch



### Features and Benefits:

- For open tank or sump applications
- 2 Pole, single level operated
- NEMA Type 1
- Manufactured for AGI in an ISO 9001 facility
- Maximum 5 hp

Approx. Weight lbs	Description	Model Number
3	Contacts Close on Liquid Rise	FU69L1986
3	Contacts Open on Liquid Rise	FU69L2073

### Float Switch Accessories

Approx. Weight lbs	Description	Model Number
.5	Plastic 6" Diameter Float	FBP6
.5	Copper Tapped 1/4"-20 Thread	FBC63

## Series F59 Two-Pole Liquid Level Switch



These weight operated switches control the liquid level in sumps. Switches are factory adjusted to operate with weights to close the contacts when the liquid rises.

Approx. Weight lbs	Voltage	Poles	HP Rating	Model Number
2	120/240	2	1	MAF59A2C

## Time Delay

Adjustable 1 second to 10 minute time delay.



Factory Setting	Description	Mounting	Model Number
30 Seconds	Timer on Delay	8-Pin Base	ELTIMER1



### Did You Know?

Munro is a UL approved industrial panel shop.

## Munro Pressure Sensor & Boot



Sensor monitors system pressure. Booted 24-volt incoming power makes it suitable for outdoor use.

**Features and Benefits:**

- Normally closed
- Fixed set point
- 1/4" NPT male
- Nema: 4, 13
- Diff. range: 8 – 16%
- Factory setting: 20 PSI

Note: Boot provides protection for electrical wire connections.

Factory Setting	Description	Mounting	Model Number
20#	Pressure Sensor	1/4" MNPT	ELSWITCH7

## Munro High Temperature Sensor



Monitors the water temperature created in a pump or auxiliary water system.

**Features and Benefits:**

- Diff range: 5-9 degrees
- Normally open

Factory Setting	Description	Mounting	Probe Length	Model Number
105°	High Temperature Sensor	1/4" MNPT	1/2"	ELTEMP2
130°			1"	ELTEMP5

## Munro Contactors



Munro's 40 AMP Relays are designed to specific parameters:

- Fully enclosed contacts
- High holding power on oversized contacts
- Low current requirements on the coil for lower required holding power
- UL and CUL Listed
- Available in 24V, 110V or 220V
- Option of a screw base or DIN rail mounting\*

Approx. Weight lbs	Description	Mounting	Coil Voltage	Model Number
.6	2-Pole Contactor 40 Amp	Fixed	24	ELRELAY1F*
			110	ELRELAY2F*
			220	ELRELAY3F*
	24		ELRELAY5P2	
	24		ELRELAY5P3	

\*Replace "F" in the part number with "D" for dinrail mount base.

## Lightning Arrestors



**Features and Benefits:**

- Clamping level – 130 VRMS
- Response times – <5 nanoseconds
- Filtering
- Energy – 500 joules, 10 x 1,000 usec
- Pulse life – 1,000 – 10,000 amp pulse
- UL 1449 Listed surge suppressor
- Complete protection between ground, neutral and phase

Approx. Weight lbs	Dimensions	Single Phase Volts	Surge Current Amps	Description	Model Number
.25	3.14 x 2.66 x 1.14	120/240	50,000	External	ELDTK120240CM
.2	3.01 x 1.69 x 1.6	110/125	39,000	Internal	ELDTK120HW

## Transducers



Measuring device used to monitor and transmit water pressure information. Stainless steel.



Approx. Weight lbs	Operating Temp	Port	Power Supply	PSI	Output	Model Number
2	35° -155°F	1/4" NPT	12-30 VDC	0-150 0-200	1-11V	SYCSP400DC SYCSP400DC200PSI

## Munro UL 50 – Type 3R Enclosures



Built to last, our UL-50 Type 3R electrical enclosures are economical and high quality. Use for controls or junction and pull.

Available Colors:

-  Powder-coated Blue
-  Stainless Steel



Approx. Weight lbs	Dimensions in	Finish	Color	Lockable	Model Number
1.8	6x6x4	Powder Coated	Blue	No	EN664B3
1.65	6x6x4	Stainless Steel	Stainless Steel	No	EN664S3
2.65	8x8x4	Powder Coated	Blue	No	EN884B3
2.60	8x8x4	Stainless Steel	Stainless Steel	No	EN884S3
7.9	12x12x6	Powder Coated	Blue	Yes	EN12126B3
7.6	12x12x6	Stainless Steel	Stainless Steel	Yes	EN12126S3
12.05	12x18x8	Powder Coated	Blue	Yes	EN12188B3
11.8	12x18x8	Stainless Steel	Stainless Steel	Yes	EN12188S3

CONTROLS

## Current Transformers



**Application** – Generally for Ammeter use only

**Frequency** – 50-400Hz.

**Insulation Class** – 50-400Hz.

- Flexible leads are UL 1015 150°C, CSA approved, #16 AWG, 24" long
- Non-standard length to be specified

**Options:**

- Terminals are brass studs No. 8-32 UNC with one flat washer, lock washer and regular nut
- SHT and SFL case styles also available as SHL and SFL with leads
- Mounting bracket kit 0221B00839 when required for MODEL 2SHT
- Approximate weight 0.5 lb.

Typical Three-Phase Horsepower		Motor Operating Amps	Model Number
460V	230V		
3-25	1-10	1 to 40	SY505CT
30-40	15-20	40 to 70	SY755CT
50	25-30	70 to 80	SY1005CT
60	40	80 to 90	SY1505CT
75-100	50-60	90 to 160	SY2005CT

## Munro Guard Pressure Switch



Low water pressure cut-off switch

Approx. Weight lbs	Min. Close Cut In	Max. Open Cut Out	1 Phase		3 Phase	Max Factory Setting	Max Static psi	NEMA 1 Model Number
			115V	230V	230V			
<b>Munro Guard - Similar to 69WC7</b>								
1/2	32	12	1 1/2	2	3	12	150	LF10WR

## Pressure Switches



Approx. Weight lbs	Min. Close Cut In	Max. Open Cut Out	Diff. Range	1 Phase		3 Phase		Factory Setting	NEMA 1 Model Number
				115V	230V	230V	460/575V		
<b>For Water Systems</b>									
1/2	3	35	4-8	1 1/2	2	3	---	5-10	FU69WA3
1/2	5	90	10-30	1 1/2	2	3	---	30-50	FU69WA43050
<b>For Air Systems</b>									
1/2	25	100	20-40	1 1/2	2	3	---	80-100	FU69MB6
1/2	40	150	30-40	1 1/2	2	3	---	95-125	FU69MB7
<b>Higher Ratings For Air Systems</b>									
1/2	40	250	35-60	2	3	5	5	115-150	FU69HA1
1/2	10	125	20-35	2	3	5	5	100-125	FU69HA2
<b>Reverse Action For Water or Air</b>									
1/2	80	10	17-22	1 1/2	2	3	---	50-30	FU69WR5
1/2	40	3	6-15	1 1/2	2	3	---	10-5	FU69WR3
Approx. Weight lbs	Min. Close Cut In	Max. Open Cut Out	Diff. Range	1 Phase		3 Phase	Fixed Low Pressure Cut Off	Factory Setting	NEMA 1 Model Number
				115V	230V	230V			
<b>Gard-All</b>									
1/2	10	70	13-30	1 1/2	2	3	6	20-40	FU69WEC
<b>Hi-Gard</b>									
1/2	20	100	--	1 1/2	3	5	--	80	FU69WH6

## Liquid Level Control



Type G Relay: Pump up and pump down control for supply pumps on elevated tanks and towers. High cutoff for pumps and valves.

Approx. Weight lbs	Contact Arrangements				HP	Model Number
	Line Volt	Norm. Closed	Norm. Open	Holding Circuit		
1	110/120	1	1	1	1	BW1500GL1S70CX
1	208/240	1	1	1	1	BW1500GL2S70CX

For use with enclosures.

## Pump Savers

### Three Phase Motor Protector

The Pump Saver reads amps and disconnects the signal to the pump if the amps get too high, to avoid burning up the motor



**Offers Protection from:**

- Over current
- Under current
- Current imbalance
- Single phasing
- Reverse phasing

Approx. Weight lbs	Power Consumption	Output Contact Rating	Control Voltage VAC	Model Number
2	5 Watts	480VA @240VAC	100-130VAC	SY520CS115
2	5 Watts	480VA @240VAC	200-250VAC	SY520CS230V
2	5 Watts	470VA @600VAC	400-500VAC	SY520CS460V

For use with enclosures.

## Power Supply Cords



Eliminates the need to hardwire a pump to power source.

Approx. Weight lbs	Volts	Length ft	Max Amps	HP Range & Type	Gauge/Cond.	Model Number
.8	115	8	15	3/4 - 1HP SJ	14/3	ELPIG14/3X8
.4	230	24 in 24 in	300	3/4 - 2HP SJ 3HP SJ	12/3 10/3	ELPIGT12/3 ELPIGT10/3

Pigtail as described above with romex and terminal connectors

Approx. Weight lbs	Volts	Length	Max Volts	Use	Gauge/Cond.	Model Number
.9	230	8 ft	300	3/4 - 2HP	12/3	12/3
	230	8 ft		3HP	10/3	10/3

## Munro Flow Sensor



This versatile flow switch offers a flow/no flow detection in pipe sizes from 1" to 6". Adjustable tension.

Size	Operation	Electrical Load	Max Amps	Flow Temp	Working Pressure	Model Number
1" NPT	NC or NO	AC24V - AC250V	15A	0-120° C 32°-248° F	150 PSI	ELFLOW1

## Wire Suspension Electrodes



Wire suspension electrodes are designed for use in applications requiring long lengths, or where limited head room prevents installation of solid rod electrodes. Type E-1P shielded electrode is assembled in a molded plastic insulating shield 7/16" in diameter. Type E-1S shielded electrode is assembled in a molded plastic shield 9/16" in diameter.

Approx. Weight oz	Length in	Electrode Material	Electrode Type	Model Number
4	4	Brass	With Shield	BW6013W1
4	4	303 Stainless		BW6013W2
2	2	Brass		BW6013W5
2	2	303 Stainless		BW6013W6
2	4	Brass	With Out Shield	BW6013W3

CONTROLS

## Munro Pump Electrical Kit



Our complete kit simplifies pump installation, with everything you need to connect to electrical controls for your pump. With convenient at-the-pump disconnect, there's no more running between the breaker box and the pump! Model Number: CP220ELECT2

**Includes:**

- **Outlet Assembly:** Waterproof outlet cover with pre-wired receptacle, 220V
- **Pressure Sensor:** NC 30 psi pressure switch, 1/4" NPT
- **Sensor Boot:** Buna rubber switch cover
- **Bushing:** 3/4" to 1/4" galvanized bushing, used to size pressure sensor to 3/4" pump port
- **Temperature Sensor:** 130° NO temperature switch
- **Wire way:** Threaded pvc nipples with 1/2" NPT Pulling El and SLB
- **Box Attachment:** 1/2" galvanized chase nipple
- **Wire:** Stranded sensor connection wire – includes disconnects

## Electrical Outlet



Cover protects outlet from water spray.

Approx. Weight lbs	Volts	Max Amps	Type	Gauge/Cond.	Model Number
1.5	110 230	20	Spec. Grade	12/3	ELCOVOUTLET1T ELCOVOUTLET2T

## Underground Wire



- UF-B Underground Sunlight Resistant
- Reel Length - 1,000 Feet

Approx. Weight lbs Per 100'	Size	Model Number
11.3	12/2 with ground	EL123GUF
15.6	10/2 with ground	EL103GUF
31.8	8/2 with ground	EL83UF
44.0	6/2 with ground	EL63UF

Available by the foot

## Submersible Cable



- Water Resistant
- Reel Length - 1,000 Feet

Weight Per Reel	Size	Model Number
16 Lbs.	12-3	SA123G
	10-3	SA103G
	8-3	SA83G

Available by the foot

## Splice Kits



Heat shrink wire splice kits – seal adhesive melt tubing and electroplated non-insulated seamless connectors included.

Wire Size	Pack Quantity	Color	Wall Type	Tube Length	Model Number
2	3	Clear	Heavy	5"	SASP2CHD
4	4	Black	Heavy	4"	SASP4HD
6	4	Clear	Heavy	4"	SASP6CHD
8	3	Black	Heavy	4"	SASP8CHD
14, 12, 10	4	Clear	Heavy	3"	SASP4CHD
14, 12, 10	12	Clear	Heavy	3"	SASP12CHD

## FROM BOOSTER AND PREPACKAGED STATIONS TO CUSTOM SOLUTIONS, MUNRO CAN BUILD IT ALL.

### WHY MUNRO?

Munro has been building pump stations since 1972, and was an early adopter of Variable Frequency Drive (VFD) technology. All Munro pump stations are designed to be low-maintenance, high-value solutions for commercial, agricultural, and residential irrigation systems.

- Maintain constant pressure in the face of varying system demands, without the hassle of large tanks, energy-robbing throttling valves, or jockey pumps.
- Prevent pumps from rapid cycling and pressure surges during start and stop
- Simplified set-up and operation, with all functions incorporated into one unit.
- Start up and support available through both the Munro team and our National Network of Service Providers.



### MUNRO WEBVIEW

With Munro Remote Monitoring, you stay in the know. Our system is web-based so you can use any device with an internet connection to get instant access to system data with just a secure log-in.

- Easy to navigate interface puts system data at your fingertips
- Visual reporting of critical information including system pressure, actual flow, motor speed and motor current
- Alerts for station faults or alarms
- All hardware and software is located on one unit

PACKAGED SYSTEMS

## MUNRO IS A PROVEN CHOICE

### A few past projects...

Fruita Elementary School, CO

Colorado Mesa University, CO

Yale University – Sachem Wood Park, CT

Nutrient Farms, CO

Oak Hill, MN

Boston College, MA

South Mountain Community College, AZ

Atlanta Botanical Gardens, GA

Venues at Longview, NJ

Albertsons, ID

Glendale High School, AZ

Q4 Ranch, CO

RTS Pedestrian Bridge, WA

The Blvd, AZ

Harvest Sports Complex, CA

Inspirada Ball Park, NV

Coonskin GC, WV

Frontier Family Park, AZ

## Munro Complete PRO II – 3/4 - 3 hp



The Munro Complete PRO II is a revolutionary complete pump package that includes a professional-grade pump, the highest quality pump control with built-in pump protection, and simplified plumbing connections – all housed in a unique enclosure designed specifically for a pump. With this complete solution, the days of purchasing and assembling numerous components and housing them in a makeshift enclosure are over!

Munro has incorporated best-in-class pump control with state-of-the-art pump protection features for the highest level of reliability and performance. With durable materials and advanced engineering, this long-lasting, quality product will be one that distributors and contractors will be confident in recommending to installers and end-users.

### ADVANTAGES

- **Easiest system to select & specify** – With only one product to buy or specify, you have everything you need for a complete pumping system.
- **Highest quality components** – Just like all of Munro’s products, the Complete PRO II is made with high-quality materials for a long, trouble-free service life.
- **Fast and easy installation** – This product ships complete, with everything you need to quickly adapt to any existing piping or electrical. All you have to do is hook it up and plug it in – it’s really that easy!



**Did You Know?**  
Munro Complete Pro IIs offer a two year warranty.

**ENCLOSURE** – Powder-coated stainless steel offers durable, non-corrosive housing to stand up to the elements.

**PUMP CONTROL** – SmartBox housed in UL-50 Type 3R enclosures features reduced amperage compatible and thermal protection. Or choose from the full range of Munro pump controls, including StartBox, SmartBox and BrainBox.

**UNIVERSAL DESIGN** – Interchangeable side panels allow for pump to face left or right.

**PUMP** – Our LP Series centrifugal pumps are durable and long lasting with industry-leading performance to horsepower. Offered in 3/4 - 3 hp, all sizes come with top-of-the-line components that are only available as costly upgrades on other pumps.

**HANDLE** – Stainless steel handle for easy accessibility.

**SECURITY** – Lockable.

**SELF COOLING** – Vented for air flow to keep the pump cool.

**FITTINGS AND ACCESSORIES** – From our one-of-a kind Munster fitting to the long-lasting hose and electrical components included, the Munro Complete PRO II is complete with everything you need.

**BALL VALVE DRAINAGE** – Never lose plugs again.

**DISCHARGE** – Discharge holes are knock-outs for easy installation. Side and base positions.

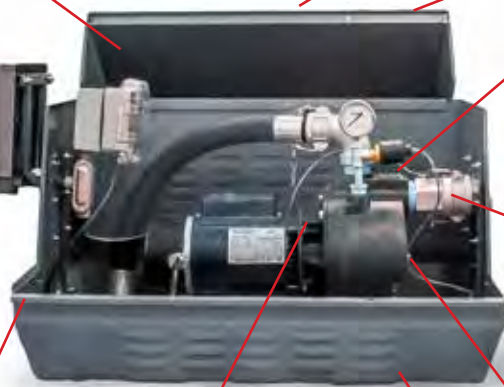

# Munro Complete PRO II – 3/4 - 3 hp

## Curves

HORSEPOWER RANGE: 3/4 - 3

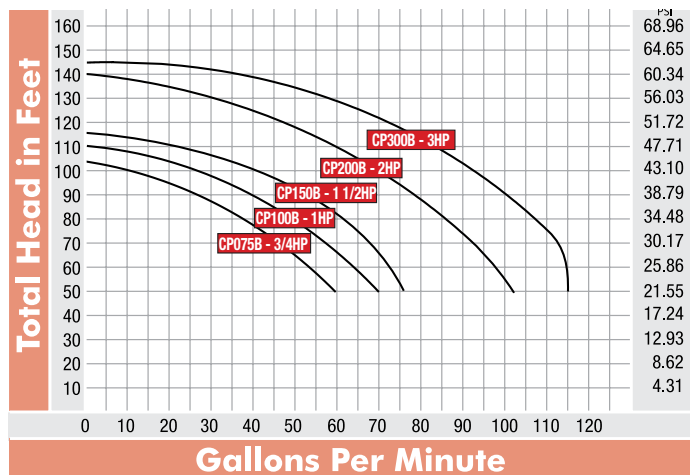

HORSEPOWER RANGE: 2

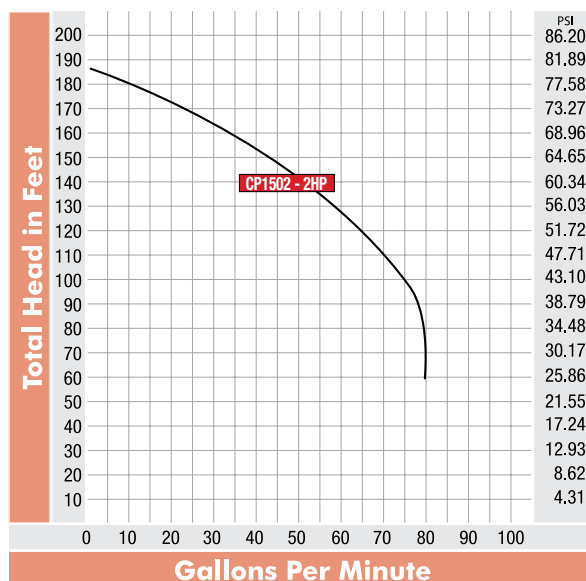

## Specifications

HP	Phase	Standard Voltage	Discharge	Suction	Dimensions			Control	Approx Ship Weight lbs	Model Number
					Height	Length	Depth			
Complete PRO II – SmartBox MPLC242W22TS										
3/4	1	208-230	1 1/2"	2"	23 1/4"	36"	19 1/2"	SmartBox	109	CP075B
1									110	CP100B
1 1/2									120	CP150B
2									128	CP200B
3									143	CP300B
3/4	3	208-230	1 1/2"	2"	23 1/4"	36"	19 1/2"	SmartBox	115	CP075B3*
1									121	CP100B3*
1 1/2									117	CP150B3*
2									128	CP200B3*
3									137	CP300B3*
2	1	208/230							168	CP1502B
2	3	208/230							163	CP1502B3*

Contact Munro for other control or voltage options.

Lead times vary for specialty or custom options.

Must specify line voltage for 3 phase.

All measurements are approximate and are subject to change.

See p.4 for complete specifications for LP series pumps.

\*SmartBox varies by hp on 3ph.

Visit [munropump.com/completevideo](http://munropump.com/completevideo) to see just how EASY irrigation pump installation can be!

PACKAGED SYSTEMS

## Munro Complete PRO II – On Demand



The easiest installation is now available with on demand controls!

The Munro Complete PRO II is already the total package, complete with a professional grade pump, the highest quality pump control, and simplified plumbing connections, all housed in a unique enclosure designed specifically for a pump.

Now, the Complete PRO II is available with our Pressure Start Control Box. Grab your hose and water your plants or wash down the driveway. The pump will automatically run on your demand for water. No need for a pressure tank! On demand controls utilizes flow and pressure to detect water demand.

### COMMON APPLICATIONS

- Recommended for: drawing water from ponds, lakes, streams, cisterns and shallow well
- Other uses: water transfer

### ADVANTAGES

- **Easiest system to select & specify** – One professional package includes pump, smart controls and enclosure
- **Trouble-free components** – High quality materials for a clean, durable installation you will be proud of
- **Hassle-free installation** – Comes complete. No parts to forget, no need for shortcuts. No fuss, no errors
- **2-year warranty** – Upgrade to CompletePRO II and get your warranty to go from 1-year to 2 years.

PACKAGED SYSTEM

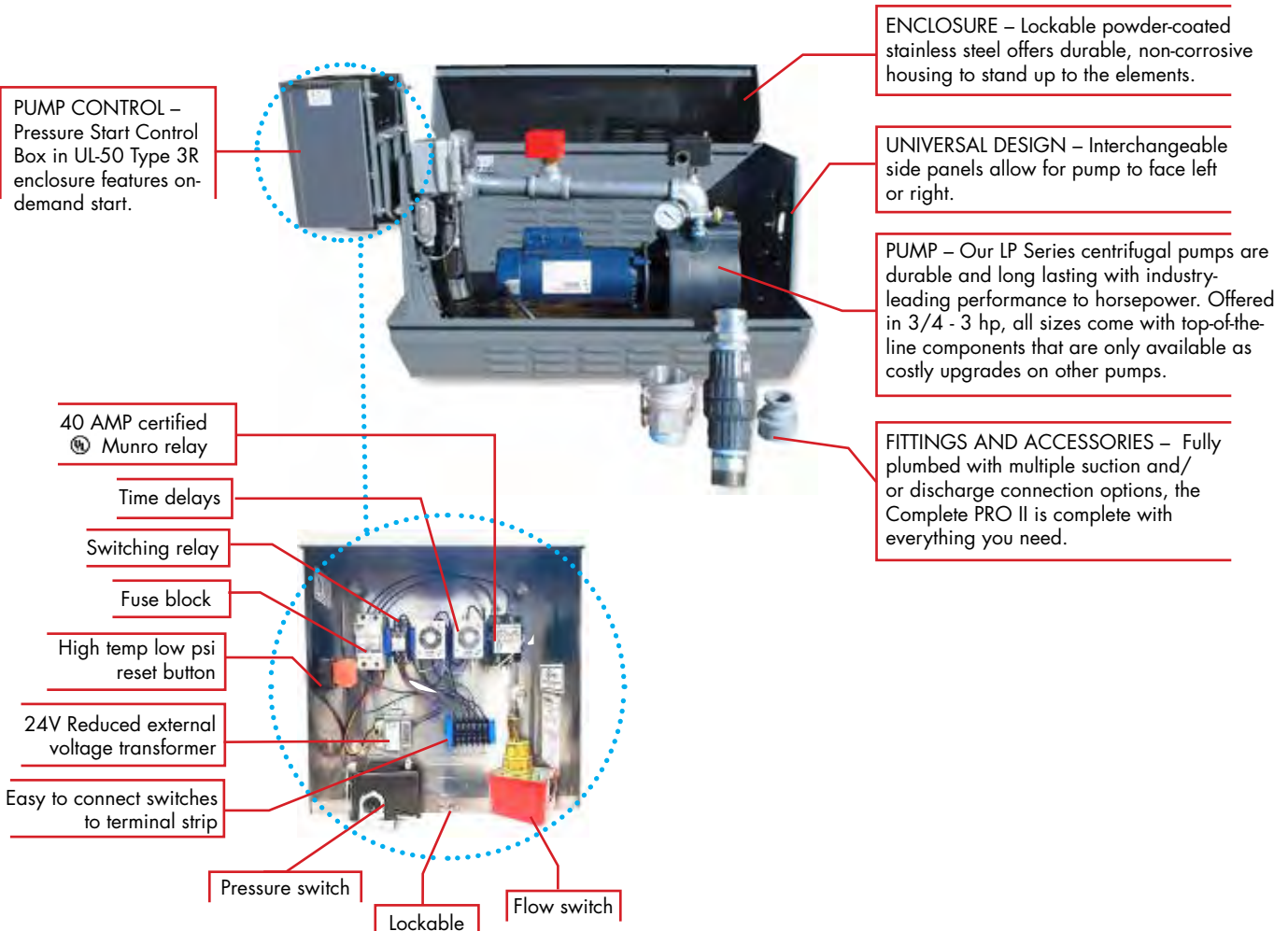

# Munro Complete PRO II – On Demand

## Curves

HORSEPOWER RANGE: 3/4 - 3

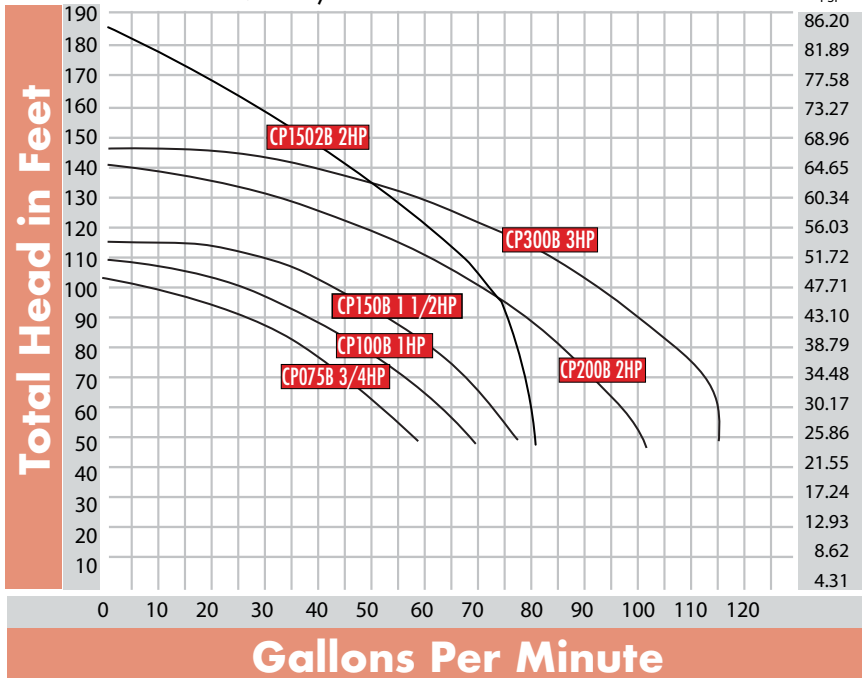

PACKAGED SYSTEMS

## Specifications

HP	Phase	Standard Voltage	Discharge	Suction	Dimensions			Control	Approx Ship Weight/Lbs	Model Number
					Height	Length	Depth			
3/4	1	208-230	1 1/2"	2"	24 1/2"	36"	19 1/2"	Pressure Start Control Box	109	CP075B220AYFT
1										CP100B220AYFT
1 1/2										CP150B220AYFT
2										CP200B220AYFT
2										CP1502B220AYFT
3										CP300B220AYFT

Available in 3 phase, must specify line voltage. Contact Munro for other control, phase or voltage options. Lead times vary for specialty or custom options. All measurements are approximate and are subject to change. See our website for complete dimensions and specifications.

## Munro Complete PRO II – 5 hp



### A Better, COMPLETE Solution

With or without enclosure

This rugged, complete pump system simplifies installation and can be customized for your application. The skid-only version is perfect for indoor installations, while the powder-coated marine grade aluminum enclosure will stand up to outdoor elements.

### ADVANTAGES

- **Easiest system to select & specify** – One professional package includes pump, smart controls and enclosure.
- **Highest quality components** – High quality materials for a clean, durable installation to be proud of.
- **Fast and easy installation** – Comes complete. No parts to forget, no need for shortcuts. No fuss, no errors.



### Did You Know?

Munro offers a variety of adapters to link a grooved coupling to your irrigation system. For steel pipe, groove x weld or groove x thread are great options. For PVC systems, grooved x spigot, groove x thread and other PVC adapters are available.

SECURITY – Lockable

PUMP CONTROL – Choose from the full range of Munro pump controls, including StartBoxes, SmartBoxes, and BrainBoxes, housed in their own UL-50 Type 3R enclosures and including features such as thermal protection, safe 24v out and run-dry protection.

ENCLOSURE OR SKID – Powder-coated marine-grade aluminum offers durable housing or base to stand up to the elements. Made to order.

SELF COOLING – Vented for air flow to keep the pump cool.

FITTINGS AND ACCESSORIES – From our rugged pipe and grooved couplings to the long-lasting electrical components included, the Munro Complete PRO II is complete with everything you need.

PUMP – Our LP Series 5 hp centrifugal pumps are durable and long lasting with industry-leading performance to horsepower.

FLANGED CONNECTION – Inlet and Outlet are flanged for easy system installation.

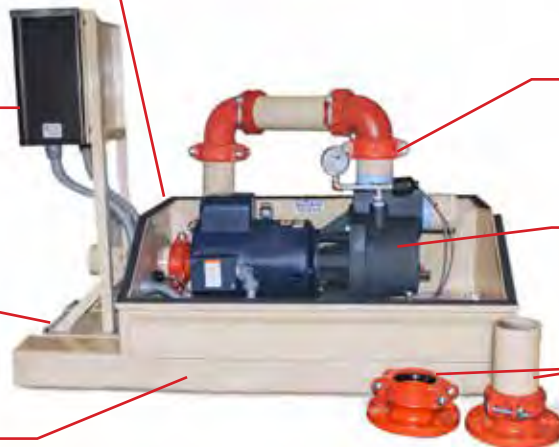

# Munro Complete PRO II – 5 hp

## Curves

HORSEPOWER RANGE: 5

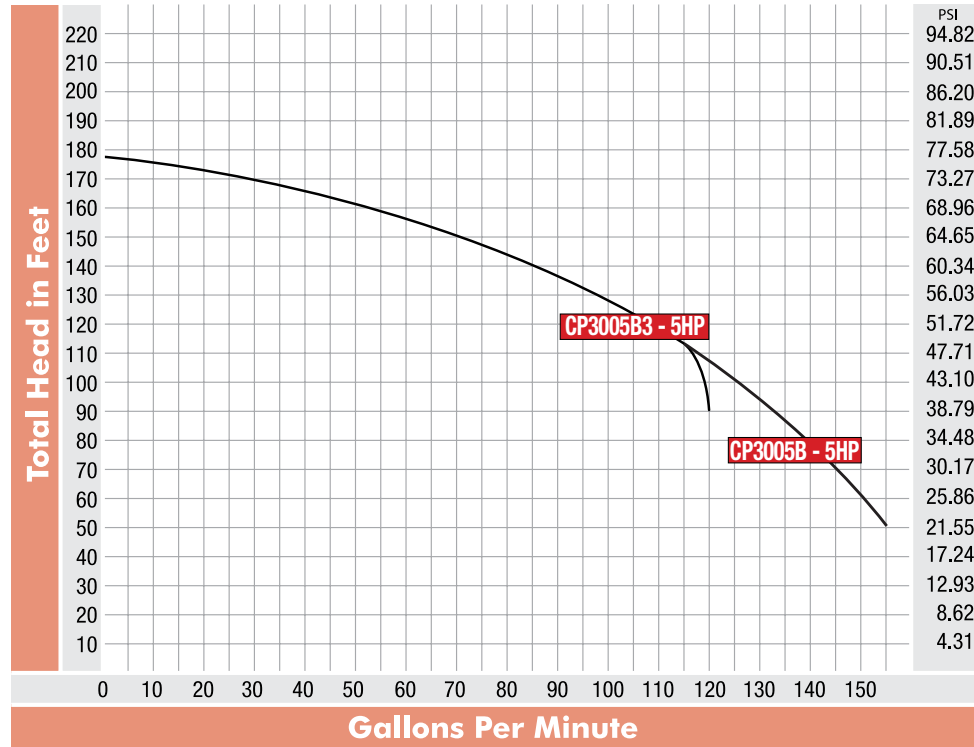

PACKAGEDSYSTEMS

## Specifications

HP	Phase	Voltage**	Discharge	Suction	Dimensions			Enclosure	Skid Mounted	Approx. Shipping Weight lbs	Model Number*	
					Height	Length	Depth					
5	1	208-230	3"	3"	35.5"	44"	22"	X		295	CP3005B	
	3	208-230									X	
	1	208-230							X		250	CP3005B-SKID
	3	208-230							X		220	CP3005B3-SKID

\* Model numbers shown are for Complete PRO II - 5hp with standard SmartBox MPLC2452WTS. Contact Munro for other control or voltage options.  
 \*\*All measurements are approximate and are subject to change, without notice.

## Munro Simplicity Pump Stations – 3 - 5 hp



This self-contained UL-QCZJ pumping station is a low-maintenance, high-value solution for commercial, agricultural, and residential irrigation systems.

- **Suction lift or pressure boost** – Specify your application to get the configuration you need.
- **True soft start and stop** – Can be started via pressure or clock
- **Constant pressure** – Avoid pressure changes on low-gallon zones
- **Quick ship** – Can ship in 2 weeks or less
- **Start-up and support** – Phone support from the Munro team as well as our national network of service providers.

### The Simplest Professional-Grade Pump Station

- **Simple specifying** – One part number, one product. It doesn't get any easier than that.
- **Simple controls** – No throttling valves or dampeners means fewer controls for simpler operation
- **Simple maintenance** – Lower operating speeds means longer life for bearings and motors, while a soft-start and controlled ramp-up reduces water hammering.

PACKAGED SYSTEMS

**VARIABLE FREQUENCY DRIVE WITH SMART SOFTWARE** – Cost saving and environmentally conscience constant pressure flow control, with pump protection features: pressure surges, loss of prime, rapid cycling, dead heading, over pressure, motor overload, low/high voltage, protections.

**FITTINGS AND ACCESSORIES** – From our rugged pipe and grooved couplings to the long-lasting gauges, valves and electrical components included, the Simplicity pump stations are complete with everything you need.

**ENCLOSURE** – Powder-coated marine-grade aluminum offers durable, non-corrosive housing to stand up to the elements.

**SELF COOLING** – Vented for air flow to keep the pump cool.

**SECURITY** – Lockable enclosure.

**PUMP** – Durable and long lasting centrifugal pumps for boost or suction lift applications, with superior performance to horsepower. Offered in 3 and 5 hp, with top-of-the-line components that are only available as costly upgrades on other pumps.



**Did You Know?**  
Ask about Z pipes!  
Munro can provide!



**Did You Know?**  
Quick Ship Pump Station! The  
Simplicity ships in 2 weeks or less.

# Munro Simplicity Pump Stations – 3 - 5 hp

## Curves

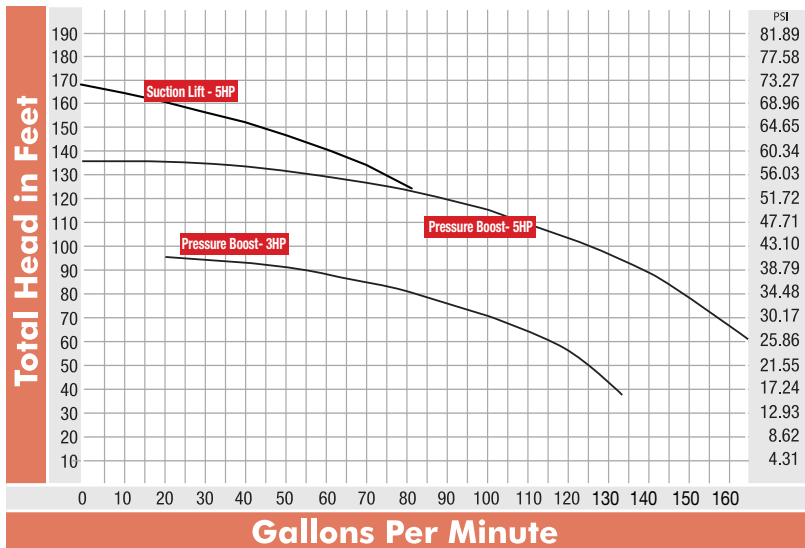

Complete our Simplicity Parameters worksheet to help us recommend the right product for your application. Page 197.

\*If you're using VFD, over 80GPM, Contact Munro.

## Dimensions

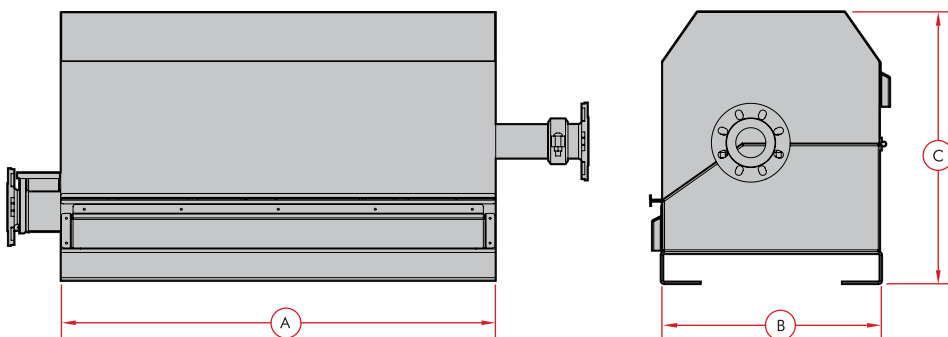

A	B	C
44"	22 1/8"	27 1/4"

## Specifications

HP	Incoming Power	Voltage	Starting Method	Discharge in	Suction in	Control	Suction Lift/ Pressure Boost	Approx Ship Weight lbs	Model Number
3	1PH	230	PRESSURE/ CLOCK	3	3	VFD	Pressure Boost	330	SIMP23031PHBP
	3PH	230						330	SIMP23033PHBP
	3PH	460						330	SIMP46033PHBP
5	1PH	230	PRESSURE/ CLOCK	3	3	VFD	Suction Lift	320	SIMP23051PHSL
	3PH	230					Suction Lift	320	SIMP23053PHSL
	3PH	460					Suction Lift	320	SIMP46053PHSL
	1PH	230					Pressure Boost	336	SIMP23051PHBP
	3PH	230					Pressure Boost	336	SIMP23053PHBP
	3PH	460					Pressure Boost	336	SIMP46053PHBP

PACKAGED SYSTEMS

## Munro StandAlone Pump Stations



Munro's StandAlone Systems are designed to provide superior performance and value, these custom-engineered, UL Listed (QCZJ), integrated control systems solve the problems associated with many packaged pump systems by minimizing cost and complexity.

The StandAlone software automates the pump station using only the VFD – no need for external logic, such as hardwired controls or PLCs. This simplification makes our pump stations easier to install and maintain, and much less costly than our competitors. Instead of costly visits from factory reps, station troubleshooting and adjustments can be handled by maintenance personnel or service provider partners and, in most cases, the system is simple enough for the end user to maintain.

Simple, efficient, and effective Munro StandAlone Pump Stations include the necessary pump, controls, suction and discharge fittings, check valves, isolation valves, skid, and enclosure to meet the demands of the application.

### Standard Features

- 3-25 HP high quality horizontal centrifugal pump
- Professional-grade VFD
- Pressure boost or suction lift configurations
- All grooved fitting assembly for ease of maintenance and quick assembly
- Powder-coated marine-grade aluminum enclosures
- Facilitated start up

### Available Options

- Touchscreen
- Remote monitoring
- Sound dampening insulation
- Baseline integration
- Intake strainers and foot valves
- Suction/discharge/z pipe
- Stainless steel enclosure
- Electromagnetic flowmeter
- Automatic filtration

### Protection Features

- Pressure surges
- Loss of prime
- Rapid cycling
- Dead heading
- Over pressure
- Motor overload
- Low/high voltage

PACKAGED SYSTEMS

## FEATURES

Lockable, powder-coated marine-grade aluminum enclosures

Pressure boost or suction lift configurations

3-25 HP high quality horizontal centrifugal pump

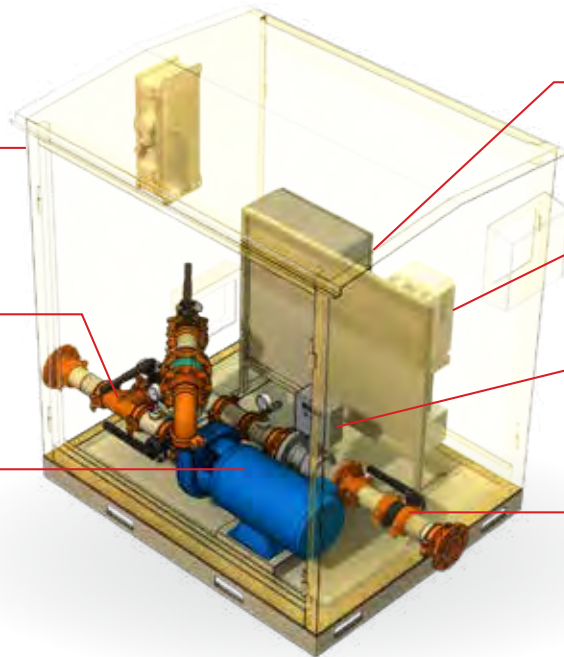

Optional remote monitoring enabled, user-friendly touchscreen

Professional-grade VFD

Optional professional-grade electromagnetic flowmeter

All grooved fittings for ease of maintenance



### Did You Know?

When you use a pump station with a VFD, you don't need a master valve. Ask to learn more.

PICK A STATION – Standard Pump Packages

PSI

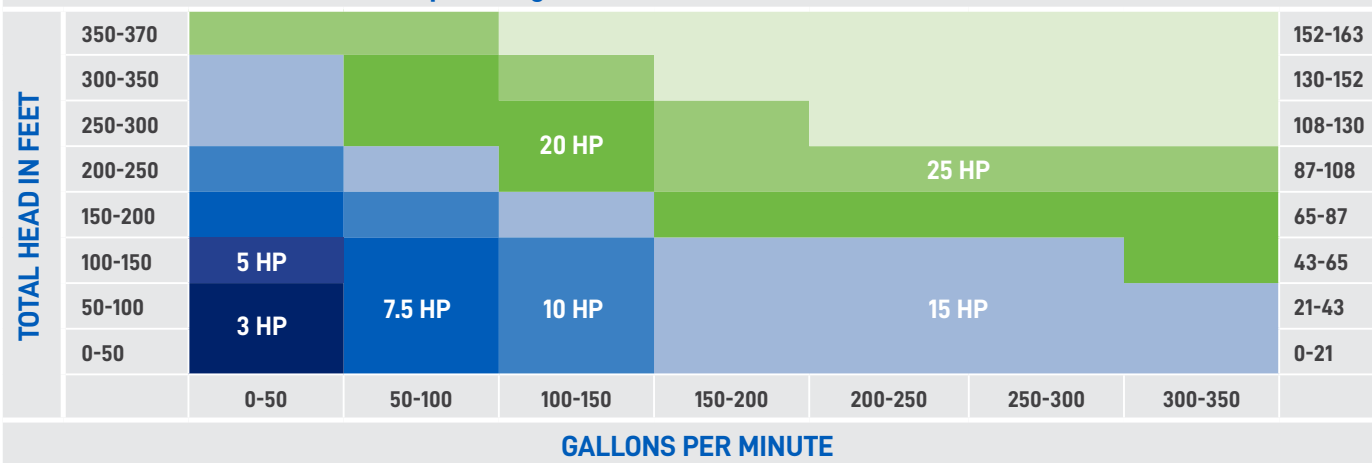

SPECS

HP	GPM	Incoming Power	Footprint	Height	Starting Method	Pipe Size
3	Up to 60	Single Phase 208-230v	5' x 4'	68.75"	Pressure or Clock	3" or 4"
5	Up to 100					
7.5	Up to 120					
10	Up to 200	Three Phase 208-230v				
15	Up to 300	Three Phase 440-480v				
20	Up to 350					
25	Up to 350					

Munro supports the professional design process at every step. We can customize the pump station you need for your project, then provide you with drawings, bid documents and more to assure your needs are fully met.

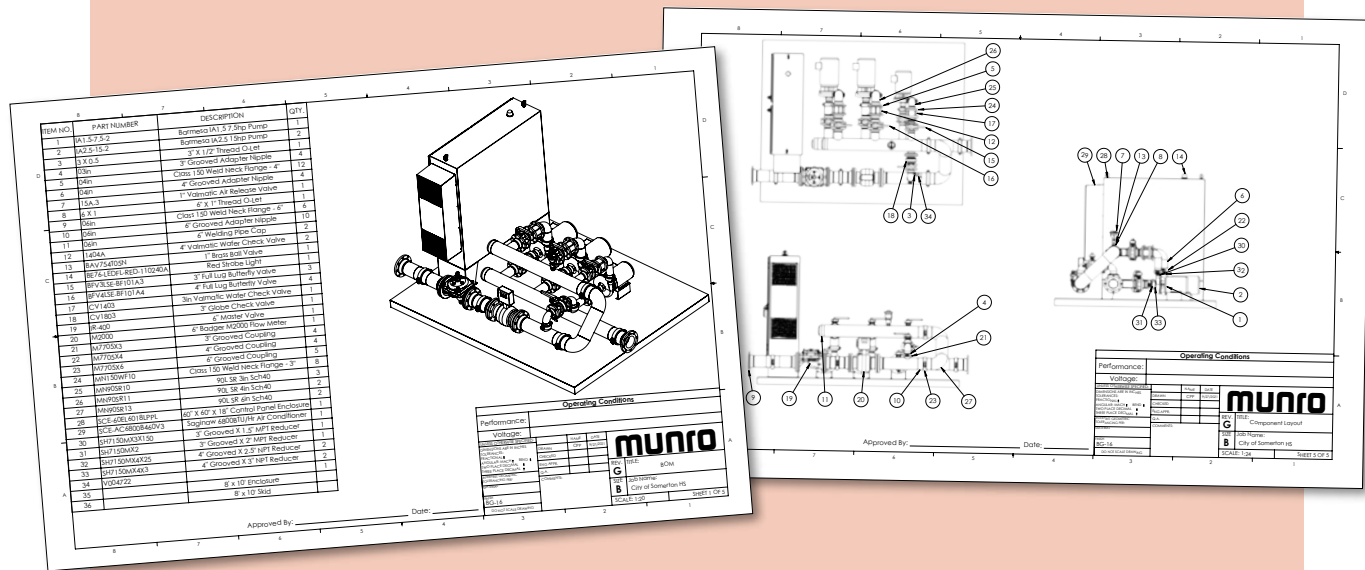

PACKAGED SYSTEMS

## Custom Prefabricated Stations

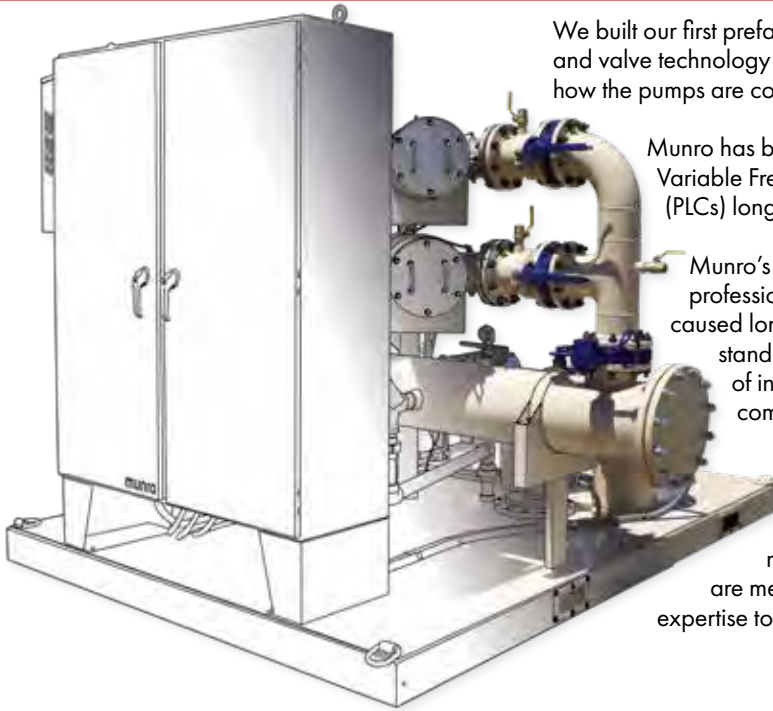

We built our first prefabricated pumping station in 1970. Although pump, pipe and valve technology has seen only minor changes, the technology that drives how the pumps are controlled has changed dramatically!

Munro has been on the cutting edge of those changes through the use of Variable Frequency Drives (VFDs) and Programmable Logic Controllers (PLCs) long before they became the industry standard.

Munro's design approach has impressed engineers and industrial professionals around the world. Some of our control concepts have caused long-time professionals to change their thinking about long-standing designs. We keep things as simple as possible, for ease of installation, use and service, but we're well equipped for complex projects.

Munro seeks out new technology and design methods to offer greater station reliability. Each system is designed and specified according to individual customer requirements, ensuring all needs and budget guidelines are met. We can help you identify the problem and apply our expertise to solve it.

### Safety is a top priority

All Munro electrical panels are listed with the Underwriters Laboratory (UL 508) to insure that our products meet rigorous safety requirements.



### Did You Know?

We test our pump stations to design parameters in our in-house test center to ensure a smooth start up.



**DESIGNED  
BUILT  
TESTED  
SERVICED**

With a personal commitment to performance, reliability and ease of use.



PACKAGED SYSTEMS



**Don't take chances! Ask if your hose distributor is a member of the NAHAD Hose Safety Institute.**

Safe hose assemblies protect your workforce, product, reputation and profitability.

- Workforce – fewer accidents, reduce lost employee time
- Product – avoid unplanned downtime, inconsistent machinery performance or poor product perception
- Reputation – safety issues could bring lawsuits, OSHA fines and environmental issues
- Profitability – any waste cuts into profitability and unsafe workplace, machinery, or equipment creates inefficiency and waste

Our hose capabilities and configurations are endless – with crimp capabilities to 10". If you need help selecting the right hose for the job, just call on the experts at Munro.

### What is the best type of hose for my application?

Important aspects for choosing the right type of hose can be summed up in an easy to remember acronym: **STAMPED**

**Size** — Inner diameter and length

**Temperature** — Minimum and maximum of the material conveyed and environmental expectations

**Application** — How will the hose be used? Suction or discharge? Will it be drug? What is the environment the hose will be in?

**Media** — What will be going through the hose? Is it water, chemicals, fuels or something else? Dirty water or clean water?

**Pressure** — To how much pressure will the assembly be exposed?

**Ends** — What type, orientation and attachment methods are needed?

**Delivery** — What are the testing, quality, packaging, and delivery requirements?

### Common hose types for irrigation applications

Suction (can be used for discharge if shape is required)

- PVC Clear – a basic, economical option (p.122)
- PVC OD critical schedule 40 sized (spa hose) – for applications where glued joints are necessary (p.123)
- PVC Industrial Strength – fabric reinforced hose with external drag helix (p.124)
- Rubber – smooth cover, good for water applications (p.125)

Discharge Layflat Hose – easy to bring to a job site and roll out for immediate use

- PVC Layflat Blue – for lower pressure applications – Max. 40–80 PSI (p.127)
- PVC Layflat Red – for medium pressures – Max. 100–150 PSI (p.127)
- Mill Hose – includes a cloth cover for added durability – Max. 150 PSI (p.128)
- Rubber Discharge Hose – industrial strength discharge hose (p.129)
- General Purpose Air & Water Hose – when garden hose will not cut it... this heavy duty hose is perfect for spray down applications or air compressor service (p.129)



#### Did You Know?

Need help selecting hose? We have a hose selection tool on p.195

### Hose End Fitting Options



King Nipples  
Page 139



C - Cam and Groove  
Coupling  
Page 134



E - Cam and Groove  
Coupling  
Page 135



Groove King Nipple  
Page 139



Crows Foot  
Page 141



Ball & Socket  
Page 140



Pin Lug  
Page 141

## PVC Water Suction Hose



PVC Water Suction Hose is general purpose water hose used for suction and discharge service in irrigation and construction. Flexible, abrasion resistant PVC with a rigid PVC helix. Temperature -4° – 150° F

Hose Size in	Approx. Hose Weight lbs/ft	Working Pressure psi	Model Number
3/4	.2	90	H0075PVC
1	.25	90	H0100PVC
1 1/4	.37	80	H01250PVC
1 1/2	.44	75	H0150PVC
2	.67	75	H0200PVC
2 1/2	.9	75	H0250PVC
3	1.14	65	H0300PVC
4	1.81	55	H0400PVC
5	3.09	35	H0500PVC
6	3.36	35	H0600PVC



C - Cam and Groove Coupling



KN - King Nipple



### Did You Know?

Hose is sold by the foot or by the assembly!

HOSE

Hose Size in	Approx. Hose Weight lbs/ft	Approx. Fittings Weight lbs	Assembled with C + King Nipple				
			5'	10'	15'	20'	25'
1 1/2	.54	2	H015PVCX5CKN	H015PVCX10CKN	H015PVCX15CKN	H015PVCX20CKN	H015PVCX25CKN
2	1.1	3	H02PVCX5CKN	H02PVCX10CKN	H02PVCX15CKN	H02PVCX20CKN	H02PVCX25CKN
3	2.1	6	H03PVCX5CKN	H03PVCX10CKN	H03PVCX15CKN	H03PVCX20CKN	H03PVCX25CKN
4	2.9	10	H04PVCX5CKN	H04PVCX10CKN	H04PVCX15CKN	H04PVCX20CKN	H04PVCX25CKN
6	5.75	25	H06PVCX5CKN	H06PVCX10CKN	H06PVCX15CKN	H06PVCX20CKN	H06PVCX25CKN



Tail Pipe Assembly



Assembly



### Get everything you need!

Add a basket strainer for a tailpipe assembly. See page 184 for Basket Strainer options!



# Schedule 40 Size Hose



Schedule 40-sized grey flexible hose is used primarily for suction line and low pressure applications where a glued end is necessary. Temperature -10° – 130° F

Hose Size in	Approx. Hose Weight in lbs/ft	Working Pressure psi	Model Number
1.0 ID X 1.32 OD	.2	90	HO100SPA
1.5 ID X 1.89 OD	.47	85	HO150SPA
2.0 ID X 2.36 OD	.66	85	HO200SPA
3.0 ID X 3.50 OD	1.20	60	HO300SPA



F - Cam and Groove Coupling



Foot Valves



Y - PVC Cam Coupler  
(Included with Assembly)

Hose Size in	Approx. Hose Weight lbs/ft	Approx. Fittings Weight lbs	Hose Kit includes aluminum fitting for pump end and PVC Foot Valve					
			5'	10'	15'	20'	25'	30'
1.5 ID X 1.89 OD	.5	2	MSHK15005FV	MSHK15010FV	MSHK15015FV	MSHK15020FV	MSHK15025FV	MSHK15030FV
2.0 ID X 2.36 OD	.67	3	MSHK20005FV	MSHK20010FV	MSHK20015FV	MSHK20020FV	MSHK20025FV	MSHK20030FV
3.0 ID X 3.50 OD	1.15	6	MSHK30005FV	MSHK30010FV	MSHK30015FV	MSHK30020FV	MSHK30025FV	MSHK30030FV

Manufactured to schedule 40 sizing specifications. Will fit into standard PVC fittings.  
 Hose expands under pressure.  
 Not intended for buried applications.



Assembly



**Did You Know?**  
 Grab-N-Go suction hose kits come with Part F camlock and Foot Valve.

HOSE

## PVC Industrial Hose



PVC Industrial strength hose is built for challenging environments. Constructed with an outside Helix and fabric reinforced shell, this hose is ideal for use in construction sites, quarries and mining or other hostile environments. Temperature -4° – 150° F

Hose Size in	Approx. Hose Weight lbs/ft	Working Pressure psi	Model Number
2	.54	100	H026200
3	1.15	100	H036200
4	1.9	75	H046200
6	4	70	H066200
8	5.25	50	H086200
10	7.8	35	H0106200
12	11	25	H0126200

20' Standard Length

Custom assemblies available with clamps or crimp sleeves.



Spiral Clamps



Crimp Sleeves



Punch-style Clamps

## Munro Centrifugal Pump Discharge Kit



Model #  
CPDKIT

Our specially designed aluminum elbow and hose assembly offers a flexible, easy connection for your discharge line. Quick disconnect camlock fittings allow easy pump removal for winterization or maintenance. Perfect for use in our Universal PRO Pump Enclosure, or anywhere you desire easy connect and disconnect access on the discharge side of your pump.

### INCLUDES:

- **Pump to fitting:** 1 1/2" NPT Nipple
- **Fitting to hose:** 1 1/2" camlock x FNPT for easy hose attachment
- **Hose:** 1 1/2" Black rubber hose, 150 working psi, 1 1/2" camlock fittings on both ends
- **Hose to irrigation inlet:** 1 1/2" PVC glue fitting marries the irrigation system piping and hose

NOTE: Keep camlock lock ears at the top and bottom to avoid leaks.

# Rubber Water Suction Hose



Rubber Water Suction Hose is a general-duty service hose. This hose offers a long life and increased bend radius when compared to general purpose PVC hose. Temperature -40° – 180° F



Hose Size in	Approx. Hose Weight lbs/ft	Working Pressure psi	Model Number
1	.54	150	H0100BRS
1 1/2	.88		H0150BRS
2	1.1		H0200BRS
2 1/2	1.55		H0250BRS
3	2.1		H0300BRS
4	2.9	100	H0400BRS
5	4.6		H0500BRS
6	5.75		H0600BRS
8	7.78		H0800BRS
10	10.29		H01000BRS
12	16.74		H01200BRS



E - Cam and Groove Coupling C - Cam and Groove Coupling



King Nipple

Hose Size in	Approx. Hose Weight lbs/ft	Approx. Fittings Weight lbs	Assembled with C + E Cam Fittings					
			5'	10'	15'	20'	25'	50'
1 1/2	.08	2	H015BRSX5CE	H015BRSX10CE	H015BRSX15CE	H015BRSX20CE	H015BRSX25CE	H015BRSX50CE
2	1.05	3	H02BRSX5CE	H02BRSX10CE	H02BRSX15CE	H02BRSX20CE	H02BRSX25CE	H02BRSX50CE
3	1.98	6	H03BRSX5CE	H03BRSX10CE	H03BRSX15CE	H03BRSX20CE	H03BRSX25CE	H03BRSX50CE
4	2.68	10	H04BRSX5CE	H04BRSX10CE	H04BRSX15CE	H04BRSX20CE	H04BRSX25CE	H04BRSX50CE
6	5.37	25	H06BRSX5CE	H06BRSX10CE	H06BRSX15CE	H06BRSX20CE	H06BRSX25CE	H06BRSX50CE

Hose Size in	Approx. Hose Weight lbs/ft	Approx. Fittings Weight lbs	Assembled with C + King Nipple					
			5'	10'	15'	20'	25'	50'
1 1/2	.08	2	H015BRSX5CKN	H015BRSX10CKN	H015BRSX15CKN	H015BRSX20CKN	H015BRSX25CKN	H015BRSX50CKN
2	1.05	3	H02BRSX5CKN	H02BRSX10CKN	H02BRSX15CKN	H02BRSX20CKN	H02BRSX25CKN	H02BRSX50CKN
3	1.98	6	H03BRSX5CKN	H03BRSX10CKN	H03BRSX15CKN	H03BRSX20CKN	H03BRSX25CKN	H03BRSX50CKN
4	2.68	10	H04BRSX5CKN	H04BRSX10CKN	H04BRSX15CKN	H04BRSX20CKN	H04BRSX25CKN	H04BRSX50CKN
6	5.37	25	H06BRSX5CKN	H06BRSX10CKN	H06BRSX15CKN	H06BRSX20CKN	H06BRSX25CKN	H06BRSX50CKN

Custom lengths available.



**Did You Know?**

Munro can build custom hose assemblies any length to fit your specific needs!

HOSE

## Oilfield Suction Hose



Designed for the most extreme environments – oilfield, underground, and coal mines. Outside corrugation gives this hose extreme flexibility and longevity.  
Temperature -20° – 180° F

Hose Size in	Approx. Hose Weight lbs/ft	Working Pressure psi	Model Number
1	.5	150	HO100SUPER
1 1/2	.7		HO150SUPER
2	.9		HO200SUPER
2 1/2	1.20		HO250SUPER
3	1.4		HO300SUPER
4	2.30		HO400SUPER
6	4.75	100	HO600SUPER
8	8.17		HO800SUPER

Hose Size in	Approx. Hose Weight lbs/ft	Approx. Fittings Weight lbs	Assembled with C + E Cam Fittings							
			5'	10'	15'	20'	25'	30'	50'	100'
1 1/2	.8	2	HO150SHX5CE	HO150SHX10CE	HO150SHX15CE	HO150SHX20CE	HO150SHX25CE	HO150SHX30CE	HO150S0HX50CE	HO150SHX100CE
2	1.05	3	HO20SHX5CE	HO20SHX10CE	HO20SHX15CE	HO20SHX20CE	HO20SHX25CE	HO20SHX30CE	HO20S0HX50CE	HO20SHX100CE
3	1.98	6	HO30SHX5CE	HO30SHX10CE	HO30SHX15CE	HO30SHX20CE	HO30SHX25CE	HO30SHX30CE	HO30S0HX50CE	HO30SHX100CE
4	2.68	10	HO40SHX5CE	HO40SHX10CE	HO40SHX15CE	HO40SHX20CE	HO40SHX25CE	HO40SHX30CE	HO40S0HX50CE	HO40SHX100CE
6	5.37	25	HO60SHX5CE	HO60SHX10CE	HO60SHX15CE	HO60SHX20CE	HO60SHX25CE	HO60SHX30CE	HO60S0HX50CE	HO60SHX100CE

Hose Size in	Approx. Hose Weight lbs/ft	Approx. Fittings Weight lbs	Assembled with C + King Nipple				
			5'	10'	15'	20'	25'
1 1/2	.8	2	HO150SHX5KN	HO150SHX10KN	HO150SHX15KN	HO150SHX20KN	HO150SHX25KN
2	1.05	3	HO20SHX5KN	HO20SHX10KN	HO20SHX15KN	HO20SHX20KN	HO20SHX25KN
3	1.98	6	HO30SHX5KN	HO30SHX10KN	HO30SHX15KN	HO30SHX20KN	HO30SHX25KN
4	2.68	10	HO40SHX5KN	HO40SHX10KN	HO40SHX15KN	HO40SHX20KN	HO40SHX25KN
6	5.37	25	HO60SHX5KN	HO60SHX10KN	HO60SHX15KN	HO60SHX20KN	HO60SHX25KN

## Petro Hose



Petroleum transfer hose is engineered for those applications for bulk transfer of petroleum products.

Hose Size in	Approx. Hose Weight lbs/ft	Working Pressure psi	Model Number
1	.5	200	HO100PETRO
1 1/2	.8	150	HO150PETRO
2	1	150	HO200PETRO
2 1/2	1.5	150	HO250PETRO
3	1.7	150	HO300PETRO
4	2.5	150	HO400PETRO
8	7.12	100	HO800PETRO



### Did You Know?

You can easily calculate the weight of a hose assembly with this simple formula!

Calculating	X	=	+	=	
Assembly Weight:	Hose Wt per Ft	Length	Subtotal	Fittings Wt	Assembly Wt

## Collapsible Discharge Hose



### Blue Collapsible Discharge Hose

Blue collapsible discharge hose can be coiled or folded, requiring little space in transporting or storage. The 300' standard rolls can be cut to any length. Perfect for low pressure applications. Temperature -10° – 120° F

Hose Size in	Approx. Hose Weight lbs/ft	Working Pressure psi	Model Number
3/4	.08	140	HO075DIS
1	.1	110	HO100DIS
1 1/4	.12	80	HO125DIS
1 1/2	.14	80	HO150DIS
2	.2	80	HO200DIS
3	.3	60	HO300DIS
4	.4	45	HO400DIS
6	.75	40	HO600DIS
8	1.1	40	HO800DIS

Hose Size in	Approx. Hose Weight lbs/ft	Approx. Fittings Weight lbs	Assembled with C + E Cam Fittings		
			25'	50'	100'
1 1/2	.14	2	HO15X25BC&E	HO15X50BC&E	HO15X100BC&E
2	.2	3	HO20X25BC&E	HO20X50BC&E	HO20X100BC&E
3	.3	6	HO30X25BC&E	HO30X50BC&E	HO30X100BC&E
4	.4	10	HO40X25BC&E	HO40X50BC&E	HO40X100BC&E
6	.75	25	HO60X25BC&E	HO60X50BC&E	HO60X100BC&E



### Red Collapsible Discharge Hose

Red medium-duty collapsible discharge hose is constructed with a premium quality PVC tube and cover reinforced with multiple spiral fabric. Temperature -5° – 170° F

Hose Size in	Approx. Hose Weight lbs/ft	Working Pressure psi	Model Number
1 1/2	.2	150	HO150DISM
2	.3		HO200DISM
3	.52		HO300DISM
4	.75		HO400DISM
6	1.25	120	HO600DISM
8	1.89		HO800DISM

Hose Size in	Approx. Hose Weight lbs/ft	Approx. Fittings Weight lbs	Assembled with C + E Cam Fittings		
			25'	50'	100'
1 1/2	.2	2	HO15X25RC&E	HO15X50RC&E	HO15X100RC&E
2	.3	3	HO20X25RC&E	HO20X50RC&E	HO20X100RC&E
3	.52	6	HO30X25RC&E	HO30X50RC&E	HO30X100RC&E
4	.75	10	HO40X25RC&E	HO40X50RC&E	HO40X100RC&E
6	1.25	25	HO60X25RC&E	HO60X50RC&E	HO60X100RC&E

## Collapsible Mill Hose



Mill Hose is a single jacket lightweight 150 PSI hose designed for clean-up and wash-down in factories and yards. An ideal industrial discharge hose. Polyester reinforces an ozone-resistant extruded synthetic rubber tube. Temperature -58° – 150° F

Hose Size in	Approx. Hose Weight lbs/ft	Working Pressure psi	Model Number
1	.12	150	HO100MILL
1 1/2	.2		HO150MILL
2	.34		HO200MILL
2 1/2	.42		HO250MILL
3	.54		HO300MILL
4	.8		HO400MILL

Hose Size in	Approx. Hose Weight lbs/ft	Approx. Fittings Weight lbs	Assembled with C + E Cam Fittings		
			25'	50'	100'
1	.12	2	HO100MILLX25	HO100MILLX50	HO100MILLX100
1 1/2	.2	3	HO150MILLX25	HO150MILLX50	HO150MILLX100
2	.34	6	HO200MILLX25	HO200MILLX50	HO200MILLX100
2 1/2	.42	7	HO250MILLX25	HO250MILLX50	HO250MILLX100
3	.54	10	HO300MILLX25	HO300MILLX50	HO300MILLX100
4	.8	25	HO400MILLX25	HO400MILLX50	HO400MILLX100

Hose Size in	Approx. Hose Weight lbs/ft	Approx. Fittings Weight lbs	Assembled with C + King Nipple		
			25'	50'	100'
1	.12	2	HO100MILLX25CKN	HO100MILLX50CKN	HO100MILLX100CKN
1 1/2	.2	3	HO150MILLX25CKN	HO150MILLX50CKN	HO150MILLX100CKN
2	.34	6	HO200MILLX25CKN	HO200MILLX50CKN	HO200MILLX100CKN
2 1/2	.42	6.5	HO250MILLX25CKN	HO250MILLX50CKN	HO250MILLX100CKN



King Nipples  
Page 139



C - Cam and Groove  
Coupling  
Page 134



E - Cam and Groove  
Coupling  
Page 135



Colorado's Oldest Listed Member

## Collapsible Discharge Hose



Black rubber water discharge hose for agricultural or construction applications. The cover is designed to withstand weather, abrasion and ozone. Temperature -40° – 180° F

Hose Size in	Approx. Hose Weight lbs/ft	Working Pressure psi	Model Number
1 1/2	.45	150	HO150BRDIS
2	.65		HO200BRDIS
2 1/2	.8		HO250BRDIS
3	1.1		HO300BRDIS
4	1.4		HO400BRDIS
5	1.6		HO500BRDIS
6	2		HO600BRDIS
8	4		HO800BRDIS
10	5		HO1000BRDIS
12	6		HO1200BRDIS

Hose Size in	Approx. Hose Weight lbs/ft	Approx. Fittings Weight lbs	Assembled with C + E Cam Fittings			
			25'	30'	50'	100'
2	.65	3	HO2BRDISX25	HO2BRDISX30	HO2BRDISX50	HO2BRDISX100
3	1.1	6	HO3BRDISX25	HO3BRDISX30	HO3BRDISX50	HO3BRDISX100
4	1.4	10	HO4BRDISX25	HO4BRDISX30	HO4BRDISX50	HO4BRDISX100
6	2	25	HO6BRDISX25	HO6BRDISX30	HO6BRDISX50	HO6BRDISX100



Hose Size in	Approx. Hose Weight lbs/ft	Approx. Fittings Weight lbs	Assembled with Grooved Ends	
			10'	25'
6	2	9.4	HO6BRDISX10VIC	HO6BRDISX25VIC
8	4	16.44	HO8BRDISX10VIC	HO8BRDISX25VIC
10	5	21.78	HO10BRDISX10VIC	HO10BRDISX25VIC
12	6	33.18	HO12BRDISX10VIC	HO12BRDISX25VIC

NOTE: 12" hose cannot be crimped.

## Air and Water Hose



Tough, economical and time-proven hose used in countless applications – wash down, service and air compression. Temperature -40° – 200° F



**Did You Know?**  
Great for winterization blowouts!

Hose Size in	Approx. Weight lbs/ft	Working Pressure psi	Model Number
1/4	.12	200	HO250200RDIS
3/8	.17		HO375200RDIS
1/2	.21		HO050200RDIS
3/4	.38		HO075200RDIS
1	.43		HO100200RDIS
1 1/4	.81		HO125200RDIS
1 1/2	.89		HO150200RDIS
2	1.28		HO200200RDIS

Hose Size in	Approx. Weight lbs/ft	Approx. Fittings Weight lbs	Assembled with Crows Foot
			50'
1/2	.21	.4	HO050X50CF
3/4	.38	.6	HO075X50CF
1	.43	.6	HO100X50CF

## Specialty Hose

### Clear Braid Hose



Temperature Range:  
-10°F to +130°F

A good discharge hose for potable water and mild chemicals. Temperature -10° – 130° F

Approx. Weight lbs/ft	Working Pressure psi	Hose Size in	Model Number
6.5	250	1/4	H0025CB
9.0		3/8	H0375CB
14		1/2	H0050CB
16		5/8	H0675CB
21	150	3/4	H0075CB
32	125	1	H0100CB
61	100	1 1/4	H01250CB
72	75	1 1/2	H0150CB
100		2	H0200CB

### Agricultural Spray Hose



Use for agricultural spraying such as insecticides, fertilizers, water, compressed air, light chemical solutions and pest control. Temperature -10° – 130° F

Approx. Weight lbs/ft	Working Pressure psi	Hose Size in	Model Number
.13	800	3/8	H0375AGS800
.20		1/2	H0050AGS800
.35		3/4	H0075AGS750
.08		1/4	H0250AGS
.12	600	3/8	H0375AGS
.17		1/2	H0050AGS
.23		5/8	H0575AGS
.27		3/4	H0075AGS

### Food Grade Suction/Discharge Hose

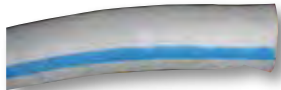

Used in food processing for suction and discharge applications. Temperature -30° – 200° F

Approx. Weight lbs/ft	Working Pressure psi	Hose Size in	Model Number
1.0	150	1 1/2	H0150FOOD
1.3		2	H0200FOOD
2.15		3	H0300FOOD
3.3		4	H0400FOOD

### Suction Hose Agricultural/Septic



Used in septic and wastewater applications. Can also be used for pump suction. Temperature -40° – 160° F

Approx. Weight lbs/ft	Hose Size in	Model Number
.28	1	H0100AGRI
.44	1 1/2	H0150AGRI
.67	2	H0200AGRI
1.14	3	H0300AGRI
1.84	4	H0400AGRI

## Hose Reels

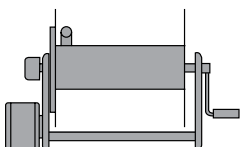
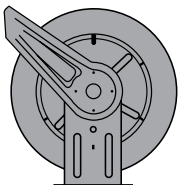

We offer air, water and grease spring driven hose reels as well as hand crank motor driven hose reels. Call us for assistance.



### Did You Know?

Call today with your specific hose application and pressure requirements.

## Heavy Duty T-Bolt Clamps



- Bolt Material:  
8.8 Grade steel. Zinc plated.
- Band and Bridge  
Material:  
Stainless steel AISI  
430 (Din 1.4016).
- Other components:  
Zinc plated steel.

Approx. Weight lbs/Carton	Carton Quantity	Range of Adjustment	Model Number	
3.2	50	13/16" - 29/32"	CL3019039	
3.26		29/32" - 1"	CL3019047	
3.29		1" - 1 1/16"	CL3019055	
6.23		1 5/16" - 1 7/16"	CL3019098	
6.24		1 7/16" - 1 9/16"	CL3019100	
6.5		1 9/16" - 1 11/16"	CL3019119	
6.96		1 11/16" - 1 7/8"	CL3019127	
7.21		1 7/8" - 2"	CL3019135	
3.79		25	2" - 2 5/32"	CL3019143
4.25			2 5/32" - 2 5/16"	CL3019151
4.31	2 5/6" - 2 1/2"		CL3019160	
4.52	2 1/2" - 2 11/16"		CL3019178	
7.22	2 11/16" - 2 7/8"		CL3019186	
7.49	2 7/8" - 3 1/8"		CL3019194	
7.61	3 1/8" - 3 11/32"		CL3019207	
7.9	3 11/32" - 3 9/16"		CL3019215	
8.14	3 9/16" - 3 13/16"		CL3019223	
8.38	3 13/16" - 4 3/32"		CL3019231	
9.33	10	4 3/32" - 4 3/8"	CL3019240	
9.55		4 3/8" - 4 3/4"	CL3019258	
7.40		5 7/8" - 6 3/8"	CL3019290	
8.10		6 3/8" - 6 7/8"	CL3019303	
9.25		8 3/8" - 8 7/8"	CL3019346	
9.70		8 7/8" - 9 3/8"	CL3019354	
10.48		12 7/16" - 13"	CL3019485	
		15		

Sold by the carton or individually.

## Punch-Style Clamps



Punch-Lok Clamps are manufactured with electrogalvanized standard steel.

Approx. Weight lbs/Carton	Description	Carton Quantity	Inside Diameter	Model Number
6.1	Galvanized	100	1"	CLCP4
6.1	Stainless Steel		1"	CLCP4S
7.5	Galvanized		1 1/4"	CLCP5
8.1	Galvanized		1 1/2"	CLCP6
8.1	Stainless Steel		1 1/2"	CLCP6S
9.6	Galvanized		2"	CLCP8
9.6	Stainless Steel	2"	CLCP8S	
5.6	Galvanized	50	2 1/2"	CLCP10
5.6	Stainless Steel		2 1/2"	CLCP10S
6.2	Galvanized		3"	CLCP12
6.5	Galvanized		3 1/2"	CLCP14
6.5	Stainless Steel		3 1/2"	CLCP14S
4.0	Galvanized		25	4"
4.0	Stainless Steel	4"		CLCP16S
4.6	Galvanized	4 1/2"		CLCP18
4.6	Stainless Steel	4 1/2"		CLCP18S
4.8	Galvanized	5"		CLCP20
4.8	Stainless Steel	5"		CLCP20S
5.1	Galvanized	50	6"	CLCP24
5.1	Stainless Steel		6"	CLCP24S
12.0	Galvanized		7"	CLCP28
12.5	Galvanized		8"	CLCP32
12.5	Stainless Steel		8"	CLCP32S

## Worm Gear Clamps



- All stainless steel construction
- Especially suited to industrial applications
- Screw: 5/16" hex-head – 304 stainless steel
- Band and housing: 1/2" wide – 300 grade stainless steel

Approx. Weight lbs/100	Range of Adjustment	Model Number
5.0	3/8" - 7/8"	CLH6SS
5.0	7/16" - 1"	CLH8SS
5.0	1/2" - 1 1/4"	CLH12SS
5.0	3/4" - 1 1/2"	CLH16SS
6.0	3/4" - 1 3/4"	CLH20SS
6.0	1" - 2"	CLH24SS
6.2	1 1/4" - 2 1/4"	CLH28SS
6.5	1 1/2" - 2 1/2"	CLH32SS
7	7/8" - 2 3/4"	CLH36SS
8.0	1 1/8" - 3"	CLH40SS
10.0	2 1/8" - 4"	CLH56SS
10.0	2 5/8" - 4 1/2"	CLH64SS
13.0	3 1/8" - 5"	CLH72SS
13	3 5/8" - 5 1/2"	CLH80SS
14.0	4 3/4" - 6 1/2"	CLH96SS

## Double Bolt Clamps



These reusable clamps provide an efficient means to secure fittings for larger size, light or heavy wall hoses. Two-bolt design provides quadruple, full-circumference take-up. Double-tongue saddles bridge the gap between the reinforced, full-width bolt lugs as clamp is tightened, preventing pinching the hose. Can be attached in field or factory with standard tools. Manufactured with plated malleable iron, with steel machine bolts and nuts.

Approx. Weight lbs	Range of Adjustment	Model Number
.5	7/8" - 1 9/64"	CL3T0029AP
.5	1 5/16" - 1 19/32"	CL3T0040AP
.5	1 5/8" - 1 15/16"	CL3T0049AP
.6	1 7/8" - 2 3/8"	CL3T0060AP
1.6	3 1/2" - 3 13/16"	CL3T0400AP
1.9	4 1/32" - 4 9/32"	CL3T0463AP
2.4	4 1/4" - 4 15/16"	CL3T0525AP
2.6	5 1/8" - 5 11/16"	CL3T0600AP
2.8	5 15/16" - 6 1/2"	CL3T0675AP
3.5	6 1/2" - 7 9/16"	CL3T0769AP
4.6	7 11/16" - 8 3/16"	CL3T0818AP
5.4	8 1/4" - 8 7/8"	CL3T0875AP
5.9	8 15/16" - 9 7/8"	CL3T0988AP
9.2	9 15/16" - 11 3/8"	CL3T1125AP
9.2	11 3/16" - 13"	CL3T1275AP
10.5	12 3/16" - 14"	CL3T1360AP

## Center Punch Tools



Approx. Weight lbs	Description	Model Number
1.1	Ratcheting tool 3/8" to 5/8" center punch clamps	CLS038
3.15	Lever tensioning tool for center punch clamps	CLB1
4.4	Screw tensioning tool for lock over clamps	CLC001
1.14	Use with CLC001 (Lever)	CLJ001
1.4	Use with CLC001 (Ratchet)	CLJ050

Munro offers a wide range of fittings and flanges to complete your hose or pipe configuration. We also offer hose assemblies complete with fittings and ready to put into the field!

## Common Fittings for Irrigation Applications

### Cam & Groove (p. 134-138)

Used in irrigation and industrial applications to make the transition from a piece of equipment to piping.

### King Nipple and Hose Menders (p. 139)

Used as inserts for hoses with threaded or grooved ends or to mend two hoses together.

### Ball and Socket (p. 140)

Primarily used in irrigation, the single lever allows for quick assembly and removal.

### Pin lug hose shank couplings (p. 141)

An economical hose insert by male thread and female thread.

### Crows foot couplings (p. 141)

Used for air, water and compressor service.

### Garden hose fittings (p. 142)

Transition from pipe thread to garden hose thread and shanks for hoses.

### Garden hose and industrial spray nozzles (p. 142)

We carry a wide variety of different materials and configurations.

### Fire hose fittings (p. 143)

These fittings transition from a fire hose thread to a pipe thread. Often used by contractors, municipalities and water treatment plants.

### Bushings, bell reducers, crosses, tees, caps, pipe nipples, elbows and swaged nipples (p. 144-150)

Components to complete your piping system.

### Flanges and flange gaskets (p. 151)

Transition from a flanged end to a thread or weld end.

### Grooved fittings (p. 153-167)

Used in countless applications from irrigation to underground coal, hard rock, mining, oil and gas.

### Clamps (p. 131-132)

From industrial to worm gear radiator style, we have all varieties of clamps.

### HDPE couplings and transition couplings (p. 164-165)

Mechanical HDPE couplings and transition couplings offer a cost-effective, fast and easy way to join high density polyethylene pipe to HDPE and grooved steel pipe and fittings.



Cam and Groove  
Page 134



King Nipples  
Page 139



Ball & Socket  
Page 140



Pin Lug  
Page 141



Crows Foot  
Page 141



Garden Hose  
Page 142



Garden Hose Nozzles  
Page 142



Fire Hose  
Page 143



Bushings  
Page 144



Flanges  
Page 151



Grooved Fittings  
Page 153-167



Clamps  
Page 131-132



HDPE  
Page 161,165

## Male Cam x Female NPT – Part A



Size in	Aluminum	Polypropylene	Nyglass	Food Grade	Brass	Stainless Steel	Ductile Iron
1/2	AP050A	HF050APG	BV050ANG	FG050A	AP050ABR	AP050ASS	AP050ADI
3/4	AP075A	HF075APG	BV075ANG	FG075A	AP075ABR	AP075ASS	AP075ADI
1	AP100A	HF100APG	BV100ANG	FG100A	AP100ABR	AP100ASS	AP100ADI
1 1/4	AP125A	HF125APG	BV125ANG	FG1250A	AP1250ABR	AP1250ASS	AP1250ADI
1 1/2	AP150A	HF150APG	BV150ANG	FG150A	AP150ABR	AP150ASS	AP150ADI
2	AP200A	HF200APG	BV200ANG	FG200A	AP200ABR	AP200ASS	AP200ADI
2 1/2	AP250A	HF250APG	BV250ANG	FG250A	AP250ABR	AP250ASS	AP250ADI
3	AP300A	HF300APG	BV300ANG	FG300A	AP300ABR	AP300ASS	AP300ADI
4	AP400A	HF400APG	BV400ANG	FG400A	AP400ABR	AP400ASS	AP400ADI
5	AP500A	—	—	—	AP500ABR	AP500ASS	AP500ADI
6	AP600A	—	—	—	AP600ABR	AP600ASS	AP600ADI
8	AP800A	—	—	—	AP800ABR	AP800ASS	AP800ADI

## Female Cam x Male NPT – Part B



Size in	Aluminum	Polypropylene	Nyglass	Food Grade	Brass	Stainless Steel	Ductile Iron
1/2	AP050B	HF050BPG	BV050BNG	FG050B	AP050BBR	AP050BSS	AP050BDI
3/4	AP075B	HF075BPG	BV075BNG	FG075B	AP075BBR	AP075BSS	AP075BDI
1	AP100B	HF100BPG	BV100BNG	FG100B	AP100BBR	AP100BSS	AP100BDI
1 1/4	AP125B	HF1250BPG	BV1250BNG	FG1250B	AP1250BBR	AP1250BSS	AP1250BDI
1 1/2	AP150B	HF150BPG	BV150BNG	FG150B	AP150BBR	AP150BSS	AP150BDI
2	AP200B	HF200BPG	BV200BNG	FG200B	AP200BBR	AP200BSS	AP200BDI
2 1/2	AP250B	HF250BPG	BV250BNG	FG250B	AP250BBR	AP250BSS	AP250BDI
3	AP300B	HF300BPG	BV300BNG	FG300B	AP300BBR	AP300BSS	AP300BDI
4	AP400B	—	BV400BNG	FG400B	AP400BBR	AP400BSS	AP400BDI
5	AP500B	—	—	—	AP500BBR	AP500BSS	AP500BDI
6	AP600B	—	—	—	AP600BBR	AP600BSS	AP600BDI
*8	AP800B	—	—	—	AP800BBR	AP800BSS	AP800BDI

## Female Cam x Hose Shank – Part C



Size in	Aluminum	Polypropylene	Nyglass	Food Grade	Brass	Stainless Steel	Ductile Iron
1/2	AP050C	HF050CPG	BV050CNG	FG050C	AP050CBR	AP050CSS	AP050CDI
3/4	AP075C	HF075CPG	BV075CNG	FG075C	AP075CBR	AP075CSS	AP075CDI
1	AP100C	HF100CPG	BV100CNG	FG100C	AP100CBR	AP100CSS	AP100CDI
1 1/4	AP125C	HF1250CPG	BV1250CNG	FG1250C	AP1250CBR	AP1250CSS	AP1250CDI
1 1/2	AP150C	HF150CPG	BV150CNG	FG150C	AP150CBR	AP150CSS	AP150CDI
2	AP200C	HF200CPG	BV200CNG	FG200C	AP200CBR	AP200CSS	AP200CDI
2 1/2	AP250C	HF250CPG	BV250CNG	FG250C	AP250CBR	AP250CSS	AP250CDI
3	AP300C	HF300CPG	BV300CNG	FG300C	AP300CBR	AP300CSS	AP300CDI
4	AP400C	HF400CPG	BV400CNG	—	AP400CBR	AP400CSS	AP400CDI
5	AP500C	—	—	—	AP500CBR	AP500CSS	AP500CDI
6	AP600C	—	—	—	AP600CBR	AP600CSS	AP600CDI
*8	AP800C	—	—	—	AP800CBR	AP800CSS	AP800CDI

Stainless fittings are available in 316 or 304. Specify when ordering.

\*8" Cam & Groove fittings are not universal across manufacturers. Consult Munro prior to order.



### Did You Know?

Heavy-duty or light-duty Cam & Groove available – ask your Munro representative!

## Female Cam x Female NPT – Part D



Size in	Aluminum	Polypropylene	Nyglass	Food Grade	Brass	Stainless Steel	Ductile Iron
1/2	AP050D	HF050DPG	BV050DNG	FG050D	AP050DBR	AP050DSS	AP050DDI
3/4	AP075D	HF075DPG	BV075DNG	FG075D	AP075DBR	AP075DSS	AP075DDI
1	AP100D	HF100DPG	BV100DNG	FG100D	AP100DBR	AP100DSS	AP100DDI
1 1/4	AP125D	HF1250DPG	BV1250DNG	FG1250D	AP1250DBR	AP1250DSS	AP1250DDI
1 1/2	AP150D	HF150DPG	BV150DNG	FG150D	AP150DBR	AP150DSS	AP150DDI
2	AP200D	HF200DPG	BV200DNG	FG200D	AP200DBR	AP200DSS	AP200DDI
2 1/2	AP250D	HF250DPG	BV250DNG	FG250D	AP250DBR	AP250DSS	AP250DDI
3	AP300D	HF300DPG	BV300DNG	FG300D	AP300DBR	AP300DSS	AP300DDI
4	AP400D	HF400DPG	BV400DNG	FG400D	AP400DBR	AP400DSS	AP400DDI
5	AP500D	—	—	—	AP500DBR	AP500DSS	AP500DDI
6	AP600D	—	—	—	AP600DBR	AP600DSS	AP600DDI
*8	AP800D	—	—	—	AP800DBR	AP800DSS	AP800DDI

## Male Cam x Hose Shank – Part E



Size in	Aluminum	Polypropylene	Nyglass	Food Grade	Brass	Stainless Steel	Ductile Iron
1/2	AP050E	HF050EPG	BV050ENG	FG050E	AP050EBR	AP050ESS	AP050EDI
3/4	AP075E	HF075EPG	BV075ENG	FG075E	AP075EBR	AP075ESS	AP075EDI
1	AP100E	HF100EPG	BV100ENG	FG100E	AP100EBR	AP100ESS	AP100EDI
1 1/4	AP125E	HF1250EPG	BV1250ENG	FG1250E	AP1250EBR	AP1250ESS	AP1250EDI
1 1/2	AP150E	HF150EPG	BV150ENG	FG150E	AP150EBR	AP150ESS	AP150EDI
2	AP200E	HF200EPG	BV200ENG	FG200E	AP200EBR	AP200ESS	AP200EDI
2 1/2	AP250E	HF250EPG	BV250ENG	FG250E	AP250EBR	AP250ESS	AP250EDI
3	AP300E	HF300EPG	BV300ENG	FG300E	AP300EBR	AP300ESS	AP300EDI
4	AP400E	HF400EPG	BV400ENG	FG400E	AP400EBR	AP400ESS	AP400EDI
5	AP500E	—	—	—	AP500EBR	AP500ESS	AP500EDI
6	AP600E	—	—	—	AP600EBR	AP600ESS	AP600EDI
*8	AP800E	—	—	—	AP800EBR	AP800ESS	AP800EDI

## Male Cam x Male NPT – Part F



Size in	Aluminum	Polypropylene	Nyglass	Food Grade	Brass	Stainless Steel	Ductile Iron
1/2	AP050F	HF050FPG	BV050FNG	FG050F	AP050FBR	AP050FSS	AP050FDI
3/4	AP075F	HF075FPG	BV075FNG	FG075F	AP075FBR	AP075FSS	AP075FDI
1	AP100F	HF100FPG	BV100FNG	FG100F	AP100FBR	AP100FSS	AP100FDI
1 1/4	AP125F	HF1250FPG	BV1250FNG	FG1250F	AP1250FBR	AP1250FSS	AP1250FDI
1 1/2	AP150F	HF150FPG	BV150FNG	FG150F	AP150FBR	AP150FSS	AP150FDI
2	AP200F	HF200FPG	BV200FNG	FG200F	AP200FBR	AP200FSS	AP200FDI
2 1/2	AP250F	HF250FPG	BV250FNG	FG250F	AP250FBR	AP250FSS	AP250FDI
3	AP300F	HF300FPG	BV300FNG	FG300F	AP300FBR	AP300FSS	AP300FDI
4	AP400F	HF400FPG	BV400FNG	FG400F	AP400FBR	AP400FSS	AP400FDI
5	AP500F	—	—	—	AP500FBR	AP500FSS	AP500FDI
6	AP600F	—	—	—	AP600FBR	AP600FSS	AP600FDI
*8	AP800F	—	—	—	AP800FBR	AP800FSS	AP800FDI

Stainless fittings are available in 316 or 304. Specify when ordering.

\*8" Cam & Groove fittings are not universal across manufacturers. Consult Munro prior to order.



### Did You Know?

8" Cam & Groove fittings are not universal across manufacturers. Consult Munro prior to order.

## Dust Cap – Part DC



Size in	Aluminum	Polypropylene	Nyglass	Food Grade	Brass	Stainless Steel	Ductile Iron
1/2	AP050DC	HF050DCPG	BV050DCNG	FG050DC	AP050DCBR	AP050DCSS	AP050DCDI
3/4	AP075DC	HF075DCPG	BV075DCNG	FG075DC	AP075DCBR	AP075DCSS	AP075DCDI
1	AP100DC	HF100DCPG	BV100DCNG	FG100DC	AP100DCBR	AP100DCSS	AP100DCDI
1 1/4	AP125DC	HF125DCPG	BV125DCNG	FG125DC	AP125DCBR	AP125DCSS	AP125DCDI
1 1/2	AP150DC	HF150DCPG	BV150DCNG	FG150DC	AP150DCBR	AP150DCSS	AP150DCDI
2	AP200DC	HF200DCPG	BV200DCNG	FG200DC	AP200DCBR	AP200DCSS	AP200DCDI
2 1/2	AP250DC	HF250DCPG	BV250DCNG	FG250DC	AP250DCBR	AP250DCSS	AP250DCDI
3	AP300DC	HF300DCPG	BV300DCNG	FG300DC	AP300DCBR	AP300DCSS	AP300DCDI
4	AP400DC	HF400DCPG	BV400DCNG	FG400DC	AP400DCBR	AP400DCSS	AP400DCDI
5	AP500DC	—	—	—	AP500DCBR	AP500DCSS	AP500DCDI
6	AP600DC	—	—	—	AP600DCBR	AP600DCSS	AP600DCDI
*8	AP800DC	—	—	—	AP800DCBR	AP800DCSS	AP800DCDI

## Dust Plug – Part DP



Size in	Aluminum	Polypropylene	Nyglass	Food Grade	Brass	Stainless Steel	Ductile Iron
1/2	AP050DP	HF050DPPG	BV050DPNG	FG050DP	AP050DPBR	AP050DPSS	AP050DPDI
3/4	AP075DP	HF075DPPG	BV075DPNG	FG075DP	AP075DPBR	AP075DPSS	AP075DPDI
1	AP100DP	HF100DPPG	BV100DPNG	FG100DP	AP100DPBR	AP100DPSS	AP100DPDI
1 1/4	AP125DP	HF125DPPG	BV125DPNG	FG125DP	AP125DPBR	AP125DPSS	AP125DPDI
1 1/2	AP150DP	HF150DPPG	BV150DPNG	FG150DP	AP150DPBR	AP150DPSS	AP150DPDI
2	AP200DP	HF200DPPG	BV200DPNG	FG200DP	AP200DPBR	AP200DPSS	AP200DPDI
2 1/2	AP250DP	HF250DPPG	BV250DPNG	FG250DP	AP250DPBR	AP250DPSS	AP250DPDI
3	AP300DP	HF300DPPG	BV300DPNG	FG300DP	AP300DPBR	AP300DPSS	AP300DPDI
4	AP400DP	HF400DPPG	BV400DPNG	FG400DP	AP400DPBR	AP400DPSS	AP400DPDI
5	AP500DP	—	—	—	AP500DPBR	AP500DPSS	AP500DPDI
6	AP600DP	—	—	—	AP600DPBR	AP600DPSS	AP600DPDI
*8	AP800DP	—	—	—	AP800DPBR	AP800DPSS	AP800DPDI

Stainless fittings are available in 316 or 304. Specify when ordering.

\*8" Cam & Groove fittings are not universal across manufacturers. Consult Munro prior to order.

## One Piece Flange x Camlock



Approx. Weight lbs	Description	Model Number
7	B Flange – Aluminum 3"	AP330FLBAL
12	B Flange – Aluminum 4"	AP340FLBAL
4	B Flange – Aluminum 6"	AP360FLBAL
6	A Flange – Aluminum 3"	AP330FLAAL
9	A Flange – Aluminum 6"	AP360FLAAL

## Schedule 40 PVC Cam Couplers & Adapters



PVC Slip X Male Cam Adapter (X)



PVC Slip X Female Cam Adapter (Y)

Approx Weight lbs	Working PSI at Temperatures				PVC Pipe Size in	Model Number
	140°	100°	80°	72°		
.06	25	65	90	105	1/2	BV050X
					1/2	BV050Y
					3/4	BV075X
					3/4	BV075Y
					1	BV100X
.50	25	65	90	105	1	BV100Y
					1 1/4	BV125X
					1 1/4	BV125Y
.67	25	65	90	105	1 1/2	BV150X
					1 1/2	BV150Y
					2	BV200X
					2	BV200Y
					3	BV300X
1.33	20	50	68	75	3	BV300Y
					3	BV300Y

## Munro Munster Fitting



Built for tank penetration, this unique one-piece design eliminates the need for separate threaded connections. The integrated hex nut makes for easy wrench installation. This fitting saves time and effort!

Size	Working Pressure psi	Length in In.	Material Description	Model Number
2"	200	5.25	Aluminum	CA2MUNSTER
4"	100	6.5		CA4MUNSTER

### GO FROM THIS...

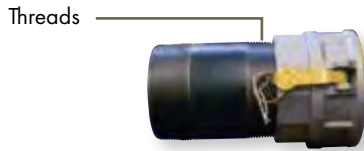

- Assembly Required
- Leak Point

### TO THE MUNSTER!

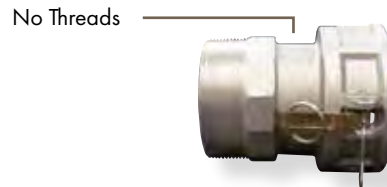

- **ONE PIECE**
- **ZERO ASSEMBLY**
- **ZERO LEAK POINTS**

## Specialty Couplers



Approx. Weight lbs	Picture Reference	Description	Model Number
1.2	90° C	2" Coupler x 90° Hose Barb	AP902CX2HB
4.0	90° C	3" Coupler x 90° 3" Hose Barb	AP903CX3HB
4.2	90° C	4" Coupler x 90° 4" Hose Barb	AP904CX4HB
3.0	90° CA	3" Coupler x 90° 3" Adapter	AP903CX3A
4.91	90° CA	4" Coupler x 90° 4" Adapter	AP904CX4A
7.25	90° CA	6" Coupler x 90° 6" Adapter	AP906CX6A
1.6	B	3" Coupler x 2" MNPT	AP3CX2MNPT
1.4	CA	1.5" Coupler x 2" Adapter	AP150CX2A
1.6	CA	2" Coupler x 1.5" Adapter	AP2CX150A
2	CA	3" Coupler x 2" Adapter	AP3CX2A
2.5	CA	3" Coupler x 2.5" Adapter	AP3CX250A
2.70	CA	4" Coupler x 2" Adapter	AP4CX2A
2.96	CA	4" Coupler x 3" Adapter	AP4CX3A
3.8	CA	5" Coupler x 4" Adapter	AP35040BAAL
6.66	CA	6" Coupler x 4" Adapter	AP6CX4A
1.4	AC	3" Coupler x 2" Adapter	AP3AX2C
0.9	AA	2" Adapter x 2" Adapter	AP2AX2A
1.45	AA	3" Adapter x 3" Adapter	AP3AX3A
2.6	AC	4" Adapter x 3" Coupler	AP4AX3C
4.8	AC	6" Adapter x 4" Coupler	AP6AX4C
2.0	C	3" Coupler x 2" Hose Barb	AP3CX2HB
2.94	C	4" Coupler x 3" Hose Barb	AP4CX3HB
1.8	E	4" Adapter x 3" Hose Barb	AP4AX3HB
1.43	CC	2" Coupler x 2" Coupler	AP2CX2C
2.4	CC	3" Coupler x 3" Coupler	AP3CX3C
3.9	CC	4" Coupler x 4" Coupler	AP4CX4C
1.91	AA	4" Adapter x 4" Adapter	AP4AX4A
5	AA	4" Adapter x 3" Adapter	AP4AX3A
5	AA	6" Adapter x 4" Adapter	AP6AX4A

45 degree couplers and additional specialty couplers also available upon request.

FITTINGS & FLANGES

## Buna-N Cam Gaskets (NBR)

Size in	Maximum Temperature	Material Description	Model Number
1/2	180° F	Buna	AP3TGBU050
3/4			AP3TGBU075
1			AP3TGBU100
1 1/4			AP3TGBU0125
1 1/2			AP3TGBU150
2			AP3TGBU200
2 1/2			AP3TGBU250
3			AP3TGBU300
4			AP3TGBU400
5			AP3TGBU500
5.5			AP3TGBU550
6			AP3TGBU600
8			AP3TGBU800
1 1/2			Buna Extra Thick
2		AP3TGXBU200	
3		AP3TGXBU300	
4		AP3TGXBU400	
6	AP3TGXBU600		



### Did You Know?

8" Cam & Groove fittings are not universal across manufacturers. Consult Munro prior to order.

## Cam Handles for Metal Cam Fittings

Size in	Description	Model Number
1/2 - 3/4	Brass Handle	AP3THRPBR075
1		AP3THRPBR100
1 1/2 - 2 1/2		AP3THRPB200
3 - 5		AP3THRPB300
6 - 8		AP3THRPB600
1/2 - 3/4	Stainless Steel Handle	AP3THRPSS075
1 1/4 - 2 1/2		AP3THRPSS125
3 - 5		AP3THRPSS300

## Munro Centrifugal Pump Suction Kit



Use this simple fitting assembly facing either direction, both parts will fit into the pump inlet. Quick cams transition from pump inlet to isolation valve on suction piping for easier installation and maintenance of your suction line. Perfect for use in our Universal PRO Pump Enclosure, or anywhere you desire easy connect and disconnect access on the suction side of your pump.

### INCLUDES:

- **Transition Fitting:** Part F, alum male cam x MNPT; AP200F
- **Munster Fitting:** Elongated Part B, alum female cam x MNPT; CA2MUNSTER

NOTE: Position camlock ears at the top and bottom to avoid leaks.

## Munro 1 1/2" Elbow



One-piece, easy-to-use transition fitting from 1 1/2" female thread to 1 1/2" male cam. No leak points – ideal for pump discharge.

NPT Thread X Male Cam	Description	Model Number
1 1/2" X 1 1/2"	Aluminum Male Cam X 90° Female Threaded Elbow	CA150ELBOW

# King Nipples & Hose Menders

	Approx. Weight lbs	Description	Hose Size in	Model Number
	.188	Plated Steel - National Pipe Thread	1/2	AP3TCNP0050
	.313		3/4	AP3TCNP0075
	.38		1	AP3TCNP0100
	.50		1 1/4	AP3TCNP1250
	.69		1 1/2	AP3TCNP0150
	.94		2	AP3TCNP0200
	1.8		2 1/2	AP3TCNP0250
	3.0		3	AP3TCNP0300
	4.94		4	AP3TCNP0400
	9.4		5	AP3TCNP0500
	12.3		6	AP3TCNP0600
	16.44		8	AP3TCNP0800
21.78	10	AP3TCNP1000		
33.18	12	AP3TCNP1200		
	.18	Stainless Steel - National Pipe Thread	1/2	AP3TCNSS050
	.26		3/4	AP3TCNSS075
	.35		1	AP3TCNSS100
	.55		1 1/4	AP3TCNSS125
	.66		1 1/2	AP3TCNSS150
	1.16		2	AP3TCNSS200
	1.31		2 1/2	AP3TCNSS250
	2.20		3	AP3TCNSS300
	3.31		4	AP3TCNSS400
			.38	Plain Steel - Grooved End
.50		1 1/4	AP3TCNV0125	
.69		1 1/2	AP3TCNV0150	
.94		2	AP3TCNV0200	
1.8		2 1/2	AP3TCNV0250	
3.0		3	AP3TCNV0300	
4.94		4	AP3TCNV0400	
9.4		6	AP3TCNV0600	
16.44		8	AP3TCNV0800	
21.78		10	AP3TCNV1000	
33.18	12	AP3TCNV1200		
	.02	NY Glass - National Pipe Thread	1/2	HF050NG
	.03		3/4	HF075NG
	.06		1	HF100NG
	.10		1 1/4	HF125NG
	.13		1 1/2	HF150NG
	.24		2	HF200NG
	.59		3	HF300NG
.89	4	HF400NG		
	.02	Poly Glass - National Pipe Thread	1/2	HF050HNPG
	.03		3/4	HF075HNPG
	.06		1	HF100HNPG
	.13		1 1/2	HF150HNPG
	.24		2	HF200HNPG
	.59		3	HF300HNPG
.89	4	HF400HNPG		
	.02	Food Grade - National Pipe Thread	1/2	FG050HN
	.03		3/4	FG075HN
	.06		1	FG100HN
	.10		1 1/4	FG125HN
	.13		1 1/2	FG150HN
	.10	Plated Steel - Hose Mender	1/2	AP3TMP050
	.125		3/4	AP3TMP075
	.25		1	AP3TMP100
	.375		1 1/4	AP3TMP125
	.50		1 1/2	AP3TMP150
	1.25		2	AP3TMP200
	2.0		2 1/2	AP3TMP250
	2.25		3	AP3TMP300
	3.0		4	AP3TMP400
	10.25		6	AP3TMP600
	20.9		8	AP3TMP800
	40		12	AP3TMP01200

FITTINGS & FLANGES

## Ball & Socket (Bauer® Style)



Hose Set

Male NPT

Male End

Female End

Lever Lock

O-Ring

Approx. Weight lbs	Description	Hose Size in	Model Number
4	Hose Set Assembly	3	WL3CS
3	Male End x Male NPT with Lever	3	WL3MENPT
2	Female End x Male NPT	3	WL3FENPT
1.5	Male End x Hose Shank Less Lever	3	WL3MALE
1.6	Female End x Hose Shank	3	WL3FEMALE
2	Lever Locking Ring	3	WL3LOCK
.13	O-Ring	3	WL3RING
12	Hose Set Assembly	4	WL4CS
7.5	Male End x Male NPT with Lever	4	WL4MENPT
3.4	Female End x Male NPT	4	WL4FENPT
3.7	Male End x Hose Shank Less Lever	4	WL4MALE
3.4	Female End x Hose Shank	4	WL4FEMALE
4	Lever Locking Ring	4	WL4LOCK
.22	O-Ring	4	WL4RING
22	Hose Set Assembly	6	WL6CS
14	Male End x Male NPT with Lever	6	WL6MENPT
6	Female End x Male NPT	6	WL6FENPT
6	Male End x Hose Shank Less Lever	6	WL6MALE
6	Female End x Hose Shank	6	WL6FEMALE
8.5	Lever Locking Ring	6	WL6LOCK
.53	O-Ring	6	WL6RING
36	Hose Set Assembly	8	WL8CS
20	Male End x Male NPT with Lever	8	WL8MENPT
12	Female End x Male NPT	8	WL8FENPT
10	Male End x Hose Shank Less Lever	8	WL8MALE
12	Female End x Hose Shank	8	WL8FEMALE
10	Lever Locking Ring	8	WL8LOCK
.66	O-Ring	8	WL8RING

Specialty ball & socket fittings also available.

## Pinlug Hose Shank Couplings

	Approx. Weight lbs	Description	Hose Size in	Model Number
	.5	Complete Set Brass	1	HF100BRPLS
	1	Complete Set Ductile Iron	1 1/2	AP3TSHC150D
	1	Complete Set Brass	1 1/2	AP3TSHC150B
	.56	Complete Set Aluminum	1 1/2	AP3TSHC150AB
	2	Complete Set Ductile Iron	2	AP3TSHC200D
	2	Complete Set Brass	2	AP3TSHC200B
	.88	Complete Set Aluminum	2	AP3TSHC200AB
	1.30	Complete Set Aluminum	2 1/2	AP3TSHC250AB
	.94	Complete Set Aluminum NST	2 1/2	AP3TSHC250ABN
	5	Complete Set Ductile Iron	3	AP3TSHC300D
	2.70	Complete Set Aluminum	3	AP3TSHC300AB
	4	Complete Set Ductile Iron	4	AP3TSHC400D
4.40	Complete Set Aluminum	4	AP3TSHC400AB	
	.25	Female Shank Brass	1	AP3TNPF100B
	.75	Female Shank Ductile Iron	1 1/2	AP3TSHF16D
	.75	Female Shank Brass	1 1/2	AP3TSHF16B
	1.25	Female Shank Ductile Iron	2	AP3TSHF21D
	1.25	Female Shank Brass	2	AP3TSHF21B
	2	Female Shank Ductile Iron	3	AP3TSHF31D
	5	Female Shank Ductile Iron	4	AP3TSHF41D
		.25	Male Shank Brass	1
.25		Male Shank Ductile Iron	1 1/2	AP3TSHM16D
.25		Male Shank Brass	1 1/2	AP3TSHM16B
.75		Male Shank Ductile Iron	2	AP3TSHM21D
.75		Male Shank Brass	2	AP3TSHM21B
3		Male Shank Ductile Iron	3	AP3TSHM31D
5		Male Shank Ductile Iron	4	AP3TSHM41D
		.5	Gasket	1
	.5	1 1/2		AP3TRW150
	.5	2		AP3TRW200
	.75	3		AP3TRW300
	1	4		AP3TRW400

## Universal Crow Foot Couplings

	Approx. Weight lbs	Description	Size in	Model Number
	.4	Female National Pipe Thread	1/2	AP3TFE050D
	.4		3/4	AP3TFE075D
	.6		1	AP3TFE100D
	.4	Hose Shank	3/8	AP3THE037D
	.4		1/2	AP3THE050D
	.6		3/4	AP3THE075D
	.6		1	AP3THE100D
	.4	Male National Pipe Thread	3/8	AP3TME037D
	.4		1/2	AP3TME050D
	.6		3/4	AP3TME075D
	.6		1	AP3TME100D
	1.0	3 Way	1/2 - 1	HF3WAY

FITTINGS & FLANGES

## Whipchecks

Whipchecks safely keep hose ends in place if a fitting failure occurs.

	Approx. Weight lbs	Description	Size in	Model Number
	.5	Hose X Hose	1/2 - 1 1/4	HFWC1
	1		1 1/2 - 3	HFWC2
	2	Hose to Manifold	4	HFWA4
	2		4 - 6	HFWC4

## Garden Hose Fittings



Approx. Weight lbs	Description	Size in	Garden Hose Thread	Model Number
.13	Male GHT	3/4	Male	GHF86GH
.13	Male NPT	3/4	Male	GHF79GHT
.10	Female NPT	3/4	Male	GHFM75X75FPT
.24	3/4" Female NPT	3/4	Female	GHF75X75F
.24	Male GHT Quick Disconnect	3/4	Female	GHF30450
.13	Short Hose Barb	5/8	Female	GHF675HBX75F
.12	Short Hose Barb	5/8	Male	GHF675HBX75M
.16	Long Hose Barb	5/8	Female	GHF30506
.17	Long Hose Barb	5/8	Male	GHF30511
.15	Short Hose Barb	3/4	Female	GHF75HBX75F
.13	Short Hose Barb	3/4	Male	GHF75HBX75M
.17	Long Hose Barb	3/4	Female	GHF29FGH1212
.20	Long Hose Barb	3/4	Male	GHF29MGH1212
.01	Red Recessed GH Washer	3/4	---	GHF30149
.01	Black Plasticized GH Washer	3/4	---	GHF30150

## Garden Hose Nozzles



Approx. Weight lbs	Description	Size in	Model Number
.8	FGHT With Insulated Handle	3/4	HF305572TFR
.7	FGHT x 3/4" MGHT	3/4	PG305573

## Spray Nozzles



Approx. Weight lbs	Description	Adjustable	Size in	Model Number
1	Brass Nozzle	X	3/4 FGHT x 6	NBGHT
.75			1 NPSM	NB1NPSM
1.25			1.25 x 10 NPSM	NB1250NPSM
3.0			1.5 FHT - NST	NB15FHT
1.75			1.5 x 12 NPSM	NB15NPSM
3.0			1.5 NPT	NB15NPT
7.0			2 NPSH	NB2NPSH
2.5			2 NPSM x 12	NB2NPSM
7.0			2.5 FHT	NB25FHT
1.4			2 x 12 x 1 Plain	NB2X12X1
.4	Plastic		3/4 FGHT	NPGHT
.5			1 NPT	NP1NPT
.5			1 1/2 FHT	NP15FHT
.5			1 1/2 NPT	NP15NPT
1.0			2 NPT	NP2NPT
2.0			2.5 FHT	NP25FHT

## Fire Hose Fittings – NST Thread

Approx. Weight lbs	Size/Description	Model Number
.5	HEX 1" M x 1" MPT	FHFM1X1MHN
.75	HEX 1 1/2" M x 1 1/2" MPT	FHFM15X15MHN
1.0	HEX 1 1/2" M x 2" MPT	FHFM15X2MHN
1.5	HEX 2 1/2" M x 1 1/2" MPT	FHFM25X15MHN
1.5	HEX 2 1/2" M x 2" MPT	FHFM25X2MHN
1.5	HEX 2 1/2" M x 2 1/2" MPT	FHFM25X25MHN
2.0	HEX 2 1/2" M x 3" MPT	FHFM25X3MHN
1.0	HEX 1 1/2" F x 1 1/2" MPT	FHFF15X15MHN
2.25	HEX 2 1/2" F x 2 1/2" MPT	FHFF25X25MHN
1.25	HEX 1 1/2" M x 2" FPT	FHFFM15X2FHN
1.0	HEX 1 1/2" M x 1 1/2" FPT	FHFM15X15FHN
2.25	HEX 2 1/2" M x 2" FPT	FHFFM25X2FHN
2.25	HEX 2 1/2" M x 2 1/2" FPT	FHFM25X25FHN
1.75	ADAPTER 2 1/2" F x 3/4" MPT	FHFF25X75MPTAD
1.75	ADAPTER 2 1/2" F x 1" MPT	FHFF25X1MPTAD
1.75	ADAPTER 2 1/2" F x 1 1/2" MPT	FHFF25X15MPTAD
2.0	ADAPTER 2 1/2" F x 2" MPT	FHFF25X2MPTAD
2.25	ADAPTER 2 1/2" F x 2 1/2" MPT	FHFF25X25MPTAD
.75	ADAPTER 1 1/2" F x 1 1/2" MPT	FHFF15X15MPTAD
2.0	ADAPTER 2 1/2" M x 2" FPT	FHFM25X2FPTAD
1.0	COUPLER 1 1/2" F x 1 1/2" FPT	FHFF15X15FPTCO
2.5	COUPLER 2 1/2" F x 2 1/2" FPT	FHFF25X25FPTCO
1.25	SWIVEL 1 1/2" F x 1 1/2" FPT	FHFF15X15FSW
2.25	SWIVEL 2 1/2" F x 1 1/2" FPT	FHFF25X15FPTSW
2.5	SWIVEL 2 1/2" F x 2" FPT	FHFF25X2FPTSW
2.5	SWIVEL 2 1/2" F x 2 1/2" FPT	FHFF25X25FPTSW
3.0	SWIVEL 2 1/2" F x 3" FPT	FHFF25X3FPTSW
1.0	SWIVEL 1" F x 1" MPT	FHFF1X1MPTSW
1.25	SWIVEL 1 1/2" F x 1 1/2" MPT	FHFF15X15MPTSW
2.5	SWIVEL 2 1/2" F x 2" MPT	FHFF25X2MPTSW
2.5	SWIVEL 2 1/2" F x 2 1/2" MPT	FHFF25X25MPTSW
3.0	SWIVEL 2 1/2" F x 3" MPT	FHFF25X3MPTSW
.75	1 1/2" CAP NST BRASS	FHF15CAP
1.75	2 1/2" CAP NST BRASS	FHF25CAP
.2	1 1/2" CAP NST RED STYRENE	FHF15CAPRS
.4	2 1/2" CAP NST RED STYRENE	FHF25CAPRS
.01	1 1/2" GASKET	FHF15GAS
.05	2 1/2" GASKET	FHF25GAS
.06	3" GASKET	FHF3GAS
1	SPANNER WRENCH	FHFWRENCH

FITTINGS & FLANGES

## Bushings



Contact us for other materials.

Size Male x Female	BRASS Model Number	GALVANIZED Model Number	BLACK STEEL Model Number
1/4" x 1/8"	BF25X125BU	SFG25X125BU	SFB25X125BU
3/8" x 1/8"	BF375X125BU	SFG375X125BU	SFB375X125BU
3/8" x 1/4"	BF375X25BU	SFG375X25BU	SFB375X25BU
1/2" x 1/8"	BF50X125BU	SFG50X125BU	SFB50X125BU
1/2" x 1/4"	BF50X25BU	SFG50X25BU	SFB50X25BU
1/2" x 3/8"	BF50X375BU	SFG50X375BU	SFB50X375BU
3/4" x 1/8"	BF75X125BU	SFG75X125BU	SFB75X125BU
3/4" x 1/4"	BF75X25BU	SFG75X25BU	SFB75X25BU
3/4" x 3/8"	BF75X375BU	SFG75X375BU	SFB75X375BU
3/4" x 1/2"	BF75X50BU	SFG75X50BU	SFB75X50BU
1" x 1/4"	BF1X25BU	SFG1X25BU	SFB1X25BU
1" x 3/8"	BF1X375BU	SFG1X375BU	SFB1X375BU
1" x 1/2"	BF1X50BU	SFG1X50BU	SFB1X50BU
1" x 3/4"	BF1X75BU	SFG1X75BU	SFB1X75BU
1 1/4" x 1/4"	BF1250X25BU	SFG1250X25BU	SFB1250X25BU
1 1/4" x 3/8"	BF1250X375BU	SFG1250X375BU	SFB1250X375BU
1 1/4" x 1/2"	BF1250X50BU	SFG1250X50BU	SFB1250X50BU
1 1/4" x 3/4"	BF1250X75BU	SFG1250X75BU	SFB1250X75BU
1 1/4" x 1"	BF1250X1BU	SFG1250X1BU	SFB1250X1BU
1 1/2" x 1/4"	BF150X25BU	SFG150X25BU	SFB150X25BU
1 1/2" x 3/8"	BF150X375BU	SFG150X375BU	SFB150X375BU
1 1/2" x 1/2"	BF150X50BU	SFG150X50BU	SFB150X50BU
1 1/2" x 3/4"	BF150X75BU	SFG150X75BU	SFB150X75BU
1 1/2" x 1"	BF150X1BU	SFG150X1BU	SFB150X1BU
1 1/2" x 1 1/4"	BF150X1250BU	SFG150X1250BU	SFB150X1250BU
2" x 3/8"	BF2X375BU	SFG2X375BU	SFB2X375BU
2" x 1/2"	BF2X50BU	SFG2X50BU	SFB2X50BU
2" x 3/4"	BF2X75BU	SFG2X75BU	SFB2X75BU
2" x 1"	BF2X1BU	SFG2X1BU	SFB2X1BU
2" x 1 1/4"	BF2X1250BU	SFG2X1250BU	SFB2X1250BU
2" x 1 1/2"	BF2X150BU	SFG2X150BU	SFB2X150BU
2 1/2" x 1"	BF250X1BU	SFG250X1BU	SFB250X1BU
2 1/2" x 1 1/2"	BF250X150BU	SFG250X150BU	SFB250X150BU
2 1/2" x 2"	BF250X2BU	SFG250X2BU	SFB250X2BU
3" x 1 1/2"	BF3X150BU	SFG3X150BU	SFB3X150BU
3" x 2"	BF3X2BU	SFG3X2BU	SFB3X2BU
3" x 2 1/2"	BF3X250BU	SFG3X250BU	SFB3X250BU
4" x 2"	BF4X2BU	SFG4X2BU	SFB4X2BU
4" x 2 1/2"	BF4X250BU	SFG4X250BU	SFB4X250BU
4" x 3"	BF4X3BU	SFG4X3BU	SFB4X3BU
5" x 4"	BF5X4BU	SFG5X4BU	SFB5X4BU
6" x 4"	BF6X4BU	SFG6X4BU	SFB6X4BU
8" x 6"	BF8X6BU	SFG8X6BU	SFB8X6BU

Various material and schedules also available.

## Bell Reducers



Contact us for other materials.

Size Female x Female	BRASS Model Number	GALVANIZED Model Number	BLACK STEEL Model Number
1/4" x 1/8"	BF25X125BE	SFG25X125BE	SFB25X125BE
3/8" x 1/8"	BF375X125BE	SFG375X125BE	SFB375X125BE
3/8" x 1/4"	BF375X25BE	SFG375X25BE	SFB375X25BE
1/2" x 1/8"	BF50X125BE	SFG50X125BE	SFB50X125BE
1/2" x 1/4"	BF50X25BE	SFG50X25BE	SFB50X25BE
1/2" x 3/8"	BF50X375BE	SFG50X375BE	SFB50X375BE
3/4" x 1/4"	BF75X25BE	SFG75X25BE	SFB75X25BE
3/4" x 3/8"	BF75X375BE	SFG75X375BE	SFB75X375BE
3/4" x 1/2"	BF75X50BE	SFG75X50BE	SFB75X50BE
1" x 1/4"	BF1X25BE	SFG1X25BE	SFB1X25BE
1" x 3/8"	BF1X375BE	SFG1X375BE	SFB1X375BE
1" x 1/2"	BF1X50BE	SFG1X50BE	SFB1X50BE
1" x 3/4"	BF1X75BE	SFG1X75BE	SFB1X75BE
1 1/4" x 1/2"	BF1250X50BE	SFG1250X50BE	SFB1250X50BE
1 1/4" x 3/4"	BF1250X75BE	SFG1250X75BE	SFB1250X75BE
1 1/4" x 1"	BF1250X1BE	SFG1250X1BE	SFB1250X1BE
1 1/2" x 1/2"	BF150X50BE	SFG150X50BE	SFB150X50BE
1 1/2" x 3/4"	BF150X75BE	SFG150X75BE	SFB150X75BE
1 1/2" x 1"	BF150X1BE	SFG150X1BE	SFB150X1BE
1 1/2" x 1 1/4"	BF150X1250BE	SFG150X1250BE	SFB150X1250BE
2" x 1/2"	BF2X50BE	SFG2X50BE	SFB2X50BE
2" x 3/4"	BF2X75BE	SFG2X75BE	SFB2X75BE
2" x 1"	BF2X75BE	SFG2X75BE	SFB2X75BE
2" x 1 1/4"	BF2X1250BE	SFG2X1250BE	SFB2X1250BE
2" x 1 1/2"	BF2X150BE	SFG2X150BE	SFB2X150BE
2 1/2" x 1 1/2"	BF250X150BE	SFG250X150BE	SFB250X150BE
2 1/2" x 2"	BF250X2BE	SFG250X2BE	SFB250X2BE
3" x 1 1/2"	BF3X150BE	SFG3X150BE	SFB3X150BE
3" x 2"	BF3X2BE	SFG3X2BE	SFB3X2BE
3" x 2 1/2"	BF3X250BE	SFG3X250BE	SFB3X250BE
4" x 2"	BF4X2BE	SFG4X2BE	SFB4X2BE
4" x 3"	BF4X3BE	SFG4X3BE	SFB4X3BE
5" x 4"	BF5X4BE	SFG5X4BE	SFB5X4BE
6" x 4"	BF6X4BE	SFG6X4BE	SFB6X4BE

Various material and schedules also available.

## Crosses



Contact us for other materials.

Size Female x Female in	BRASS Model Number	GALVANIZED Model Number	BLACK STEEL Model Number
1/4	BF25CR	SFG25CR	SFB25CR
3/8	BF375CR	SFG375CR	SFB375CR
1/2	BF50CR	SFG50CR	SFB50CR
3/4	BF75CR	SFG75CR	SFB75CR
1	BF1CR	SFG1CR	SFB1CR
1 1/4	BF1250CR	SFG1250CR	SFB1250CR
1 1/2	BF150CR	SFG150CR	SFB150CR
2	BF2CR	SFG2CR	SFB2CR
3	BF3CR	SFG3CR	SFB3CR

Various material and schedules also available.

## Tees



Contact us for other materials.

Size Female x Female in	BRASS Model Number	GALVANIZED Model Number	BLACK STEEL Model Number
1/8	BF125TE	SFG125TE	SFB125TE
1/4	BF25TE	SFG25TE	SFB25TE
3/8	BF375TE	SFG375TE	SFB375TE
1/2	BF50TE	SFG50TE	SFB50TE
3/4	BF75TE	SFG75TE	SFB75TE
1	BF1TE	SFG1TE	SFB1TE
1 1/4	BF1250TE	SFG1250TE	SFB1250TE
1 1/2	BF150TE	SFG150TE	SFB150TE
2	BF2TE	SFG2TE	SFB2TE
2 1/2	BF250TE	SFG250TE	SFB250TE
3	BF3TE	SFG3TE	SFB3TE
4	BF4TE	SFG4TE	SFB4TE
6	BF6TE	SFG6TE	SFB6TE

Various material and schedules also available.

## Caps



Contact us for other materials.

Size in	BRASS Model Number	GALVANIZED Model Number	BLACK STEEL Model Number
1/8	BF125CA	SFG125CA	SFB125CA
1/4	BF25CA	SFG25CA	SFB25CA
3/8	BF375CA	SFG375CA	SFB375CA
1/2	BF50CA	SFG50CA	SFB50CA
3/4	BF75CA	SFG75CA	SFB75CA
1	BF1CA	SFG1CA	SFB1CA
1 1/4	BF1250CA	SFG1250CA	SFB1250CA
1 1/2	BF150CA	SFG150CA	SFB150CA
2	BF2CA	SFG2CA	SFB2CA
2 1/2	BF250CA	SFG250CA	SFB250CA
3	BF3CA	SFG3CA	SFB3CA
4	BF4CA	SFG4CA	SFB4CA
6	BF6CA	SFG6CA	SFB6CA

Various material and schedules also available.

## Plugs



Contact us for other materials.

Size Male in	BRASS Model Number	GALVANIZED Model Number	BLACK STEEL Model Number
1/8	BF125PL	SFG125PL	SFB125PL
1/4	BF25PL	SFG25PL	SFB25PL
3/8	BF375PL	SFG375PL	SFB375PL
1/2	BF50PL	SFG50PL	SFB50PL
3/4	BF75PL	SFG75PL	SFB75PL
1	BF1PL	SFG1PL	SFB1PL
1 1/4	BF1250PL	SFG1250PL	SFB1250PL
1 1/2	BF150PL	SFG150PL	SFB150PL
2	BF2PL	SFG2PL	SFB2PL
2 1/2	BF250PL	SFG250PL	SFB250PL
3	BF3PL	SFG3PL	SFB3PL
4	BF4PL	SFG4PL	SFB4PL

Various material and schedules also available.

## Couplers



Contact us for other materials.

Size Female in	BRASS Model Number	GALVANIZED Model Number	BLACK STEEL Model Number
1/8	BF125CO	SFG125CO	SFB125CO
1/4	BF25CO	SFG25CO	SFB25CO
3/8	BF375CO	SFG375CO	SFB375CO
1/2	BF50CO	SFG50CO	SFB50CO
3/4	BF75CO	SFG75CO	SFB75CO
1	BF1CO	SFG1CO	SFB1CO
1 1/4	BF1250CO	SFG1250CO	SFB1250CO
1 1/2	BF150CO	SFG150CO	SFB150CO
2	BF2CO	SFG2CO	SFB2CO
2 1/2	BF250CO	SFG250CO	SFB250CO
3	BF3CO	SFG3CO	SFB3CO
4	BF4CO	SFG4CO	SFB4CO
6	BF6CO	SFG6CO	SFB6CO
8	BF8CO	SFG8CO	SFB8CO

Various material and schedules also available.

## 45° Street Elbows



Contact us for other materials.

Size Male x Female in	BRASS Model Number	GALVANIZED Model Number	BLACK STEEL Model Number
1/4"	BF25EL45	SFG25EL45	SFB25EL45
3/8"	BF375EL45	SFG375EL45	SFB375EL45
1/2"	BF50EL45	SFG50EL45	SFB50EL45
3/4"	BF75EL45	SFG75EL45	SFB75EL45
1"	BF1EL45	SFG1EL45	SFB1EL45
1 1/4"	BF1250EL45	SFG1250EL45	SFB1250EL45
1 1/2"	BF150EL45	SFG150EL45	SFB150EL45
2"	BF2EL45	SFG2EL45	SFB2EL45
3"	BF3EL45	SFG3EL45	SFB3EL45
4"	BF4EL45	SFG4EL45	SFB4EL45

Various material and schedules also available.

## 45° Elbows



Contact us for other materials.

Size Female x Female in	BRASS Model Number	GALVANIZED Model Number	BLACK STEEL Model Number
1/8	BF125EL45	SFG125EL45	SFB125EL45
1/4	BF25EL45	SFG25EL45	SFB25EL45
3/8	BF375EL45	SFG375EL45	SFB375EL45
1/2	BF50EL45	SFG50EL45	SFB50EL45
3/4	BF75EL45	SFG75EL45	SFB75EL45
1	BF1EL45	SFG1EL45	SFB1EL45
1 1/4	BF1250EL45	SFG1250EL45	SFB1250EL45
1 1/2	BF150EL45	SFG150EL45	SFB150EL45
2	BF2EL45	SFG2EL45	SFB2EL45
3	BF3EL45	SFG3EL45	SFB3EL45
4	BF4EL45	SFG4EL45	SFB4EL45
6	BF6EL45	SFG6EL45	SFB6EL45

Various material and schedules also available.

## 90° Elbows



Contact us for other materials.

Size Female x Female in	BRASS Model Number	GALVANIZED Model Number	BLACK STEEL Model Number
1/8	BF125EL	SFG125EL	SFB125EL
1/4	BF25EL	SFG25EL	SFB25EL
3/8	BF375EL	SFG375EL	SFB375EL
1/2	BF50EL	SFG50EL	SFB50EL
3/4	BF75EL	SFG75EL	SFB75EL
1	BF1EL	SFG1EL	SFB1EL
1 1/4	BF1250EL	SFG1250EL	SFB1250EL
1 1/2	BF150EL	SFG150EL	SFB150EL
2	BF2EL	SFG2EL	SFB2EL
2 1/2	BF250EL	SFG250EL	SFB250EL
3	BF3EL	SFG3EL	SFB3EL
4	BF4EL	SFG4EL	SFB4EL
6	BF6EL	SFG6EL	SFB6EL
8	BF8EL	SFG8EL	SFB8EL

Various material and schedules also available.

## 90° Street Elbows



Contact us for other materials.

Size Male x Female in	BRASS Model Number	GALVANIZED Model Number	BLACK STEEL Model Number
1/8	BF125STEL	SFG125STEL	SFB125STEL
1/4	BF25STEL	SFG25STEL	SFB25STEL
3/8	BF375STEL	SFG375STEL	SFB375STEL
1/2	BF50STEL	SFG50STEL	SFB50STEL
3/4	BF75STEL	SFG75STEL	SFB75STEL
1	BF1STEL	SFG1STEL	SFB1STEL
1 1/4	BF1250STEL	SFG1250STEL	SFB1250STEL
1 1/2	BF150STEL	SFG150STEL	SFB150STEL
2	BF2STEL	SFG2STEL	SFB2STEL
2 1/2	BF250STEL	SFG250STEL	SFB250STEL
3	BF3STEL	SFG3STEL	SFB3STEL
4	BF4STEL	SFG4STEL	SFB4STEL
6	BF6STEL	SFG6STEL	SFB6STEL

Various material and schedules also available.

# Pipe Nipples



Contact us for other materials.

Size	BRASS Model Number	GALVANIZED Model Number	BLACK STEEL Model Number
1/8" x Close (3/4") 1/8" x 2" 1/8" x 2 1/2" 1/8" x 3" 1/8" x 4" 1/8" x 5" 1/8" x 6" 1/8" x 8" 1/8" x 10" 1/8" x 12"	BF125XCLOSENI BF125X2NI BF125X25NI BF125X3NI BF125X4NI BF125X5NI BF125X6NI BF125X8NI BF125X10NI BF125X12NI	SFG125XCLOSENI SFG125X2NI SFG125X25NI SFG125X3NI SFG125X4NI SFG125X5NI SFG125X6NI SFG125X8NI SFG125X10NI SFG125X12NI	SFB125XCLOSENI SFB125X2NI SFB125X25NI SFB125X3NI SFB125X4NI SFB125X5NI SFB125X6NI SFB125X8NI SFB125X10NI SFB125X12NI
1/4" x Close (7/8") 1/4" x 1 1/2" 1/4" x 2" 1/4" x 3" 1/4" x 4" 1/4" x 5" 1/4" x 6" 1/4" x 8" 1/4" x 10" 1/4" x 12"	BF25XCLOSENI BF25X15NI BF25X2NI BF25X3NI BF25X4NI BF25X5NI BF25X6NI BF25X8NI BF25X10NI BF25X12NI	SFG25XCLOSENI SFG25X15NI SFG25X2NI SFG25X3NI SFG25X4NI SFG25X5NI SFG25X6NI SFG25X8NI SFG25X10NI SFG25X12NI	SFB25XCLOSENI SFB25X15NI SFB25X2NI SFB25X3NI SFB25X4NI SFB25X5NI SFB25X6NI SFB25X8NI SFB25X10NI SFB25X12NI
3/8" x Close (1") 3/8" x 2" 3/8" x 3" 3/8" x 4" 3/8" x 5" 3/8" x 6" 3/8" x 8" 3/8" x 10" 3/8" x 12"	BF375XCLOSENI BF375X2NI BF375X3NI BF375X4NI BF375X5NI BF375X6NI BF375X8NI BF375X10NI BF375X12NI	SFG375XCLOSENI SFG375X2NI SFG375X3NI SFG375X4NI SFG375X5NI SFG375X6NI SFG375X8NI SFG375X10NI SFG375X12NI	SFB375XCLOSENI SFB375X2NI SFB375X3NI SFB375X4NI SFB375X5NI SFB375X6NI SFB375X8NI SFB375X10NI SFB375X12NI
1/2" x Close (1 1/8") 1/2" x 2" 1/2" x 3" 1/2" x 4" 1/2" x 5" 1/2" x 6" 1/2" x 8" 1/2" x 10" 1/2" x 12"	BF50XCLOSENI BF50X2NI BF50X3NI BF50X4NI BF50X5NI BF50X6NI BF50X8NI BF50X10NI BF50X12NI	SFG50XCLOSENI SFG50X2NI SFG50X3NI SFG50X4NI SFG50X5NI SFG50X6NI SFG50X8NI SFG50X10NI SFG50X12NI	SFB50XCLOSENI SFB50X2NI SFB50X3NI SFB50X4NI SFB50X5NI SFB50X6NI SFB50X8NI SFB50X10NI SFB50X12NI
3/4" x Close (3/4") 3/4" x 2" 3/4" x 3" 3/4" x 4" 3/4" x 5" 3/4" x 6" 3/4" x 8" 3/4" x 10" 3/4" x 12"	BF75XCLOSENI BF75X2NI BF75X3NI BF75X4NI BF75X5NI BF75X6NI BF75X8NI BF75X10NI BF75X12NI	SFG75XCLOSENI SFG75X2NI SFG75X3NI SFG75X4NI SFG75X5NI SFG75X6NI SFG75X8NI SFG75X10NI SFG75X12NI	SFB75XCLOSENI SFB75X2NI SFB75X3NI SFB75X4NI SFB75X5NI SFB75X6NI SFB75X8NI SFB75X10NI SFB75X12NI
1" x Close (1 1/2") 1" x 2" 1" x 3" 1" x 4" 1" x 5" 1" x 6" 1" x 8" 1" x 10" 1" x 12"	BF1XCLOSENI BF1X2NI BF1X3NI BF1X4NI BF1X5NI BF1X6NI BF1X8NI BF1X10NI BF1X12NI	SFG1XCLOSENI SFG1X2NI SFG1X3NI SFG1X4NI SFG1X5NI SFG1X6NI SFG1X8NI SFG1X10NI SFG1X12NI	SFB1XCLOSENI SFB1X2NI SFB1X3NI SFB1X4NI SFB1X5NI SFB1X6NI SFB1X8NI SFB1X10NI SFB1X12NI
1 1/4" x Close (1") 1 1/4" x 2" 1 1/4" x 3" 1 1/4" x 4" 1 1/4" x 5" 1 1/4" x 6" 1 1/4" x 8" 1 1/4" x 10" 1 1/4" x 12"	BF125XCLOSENI BF125X2NI BF125X25NI BF125X3NI BF125X4NI BF125X5NI BF125X6NI BF125X8NI BF125X10NI	SFG125XCLOSENI SFG125X2NI SFG125X25NI SFG125X3NI SFG125X4NI SFG125X5NI SFG125X6NI SFG125X8NI SFG125X10NI	SFB125XCLOSENI SFB125X2NI SFB125X25NI SFB125X3NI SFB125X4NI SFB125X5NI SFB125X6NI SFB125X8NI SFB125X10NI

Various material and schedules also available.

FITTINGS & FLANGES

## Pipe Nipples



Contact us for other materials.



**Did You Know?**  
Eccentric reducers eliminate a possible air pocket in a suction reducer. Always install with the flat side up.

Size	BRASS Model Number	GALVANIZED Model Number	BLACK STEEL Model Number
1 1/2" x Close (1 3/4")	BF150XCLOSENI	SFG150XCLOSENI	SFB150XCLOSENI
1 1/2" x 2"	BF150X2NI	SFG150X2NI	SFB150X2NI
1 1/2" x 3"	BF150X3NI	SFG150X3NI	SFB150X3NI
1 1/2" x 4"	BF150X4NI	SFG150X4NI	SFB150X4NI
1 1/2" x 5"	BF150X5NI	SFG150X5NI	SFB150X5NI
1 1/2" x 6"	BF150X6NI	SFG150X6NI	SFB150X6NI
1 1/2" x 8"	BF150X8NI	SFG150X8NI	SFB150X8NI
1 1/2" x 10"	BF150X10NI	SFG150X10NI	SFB150X10NI
1 1/2" x 12"	BF150X12NI	SFG150X12NI	SFB150X12NI
2" x Close (2")	BF2XCLOSENI	SFG2XCLOSENI	SFB2XCLOSENI
2" x 3"	BF2X3NI	SFG2X3NI	SFB2X3NI
2" x 4"	BF2X4NI	SFG2X4NI	SFB2X4NI
2" x 6"	BF2X6NI	SFG2X6NI	SFB2X6NI
2" x 8"	BF2X8NI	SFG2X8NI	SFB2X8NI
2" x 10"	BF2X10NI	SFG2X10NI	SFB2X10NI
2" x 12"	BF2X12NI	SFG2X12NI	SFB2X12NI
2 1/2" x Close (2 1/2")	BF250XCLOSENI	SFG250XCLOSENI	SFB250XCLOSENI
2 1/2" x 3"	BF250X3NI	SFG250X3NI	SFB250X3NI
2 1/2" x 6"	BF250X6NI	SFG250X6NI	SFB250X6NI
3" x Close (2 5/8")	BF3XCLOSENI	SFG3XCLOSENI	SFB3XCLOSENI
3" x 3"	BF3X3NI	SFG3X3NI	SFB3X3NI
3" x 4"	BF3X4NI	SFG3X4NI	SFB3X4NI
3" x 6"	BF3X6NI	SFG3X6NI	SFB3X6NI
3" x 8"	BF3X8NI	SFG3X8NI	SFB3X8NI
3" x 10"	BF3X10NI	SFG3X10NI	SFB3X10NI
3" x 12"	BF3X12NI	SFG3X12NI	SFB3X12NI
4" x Close (2 7/8")	BF4XCLOSENI	SFG4XCLOSENI	SFB4XCLOSENI
4" x 4"	BF4X4NI	SFG4X4NI	SFB4X4NI
4" x 6"	BF4X6NI	SFG4X6NI	SFB4X6NI
4" x 8"	BF4X8NI	SFG4X8NI	SFB4X8NI
4" x 10"	BF4X10NI	SFG4X10NI	SFB4X10NI
4" x 12"	BF4X12NI	SFG4X12NI	SFB4X12NI
5" x 8"	BF5X8NI	SFG5X8NI	SFB5X8NI
6" x Close	BF6XCLOSENI	SFG6XCLOSENI	SFB6XCLOSENI
6" x 4"	BF6X4NI	SFG6X4NI	SFB6X4NI
6" x 4 1/2"	BF6X45NI	SFG6X45NI	SFB6X45NI
6" x 5"	BF6X5NI	SFG6X5NI	SFB6X5NI
6" x 6"	BF6X6NI	SFG6X6NI	SFB6X6NI
6" x 8"	BF6X8NI	SFG6X8NI	SFB6X8NI
6" x 10"	BF6X10NI	SFG6X10NI	SFB6X10NI

Various material and schedules also available.

## Grooved & Threaded Eccentric Swage Nipples



- Suction pipe size should be one pipe size larger than pump inlet.
- Proper design of suction piping should have a maximum velocity of four to six feet per second.
- Any velocity over eight feet per second may result in damage to the pump.
- Orient the eccentric swage nipple with the flat side up.

Nominal Size in	Length in	Approx. Weight lbs	Model Number
3 X 2 NPT	8.0	4.51	MEC2X3NPT
4 X 3 NPT	9.0	7.04	MEC3X4NPT
6 X 4 NPT	12.0	15.99	MEC4X6NPT
3 X 2 GROOVE	8.0	4.51	MEC2X3GRV
4 X 3 GROOVE	9.0	7.04	MEC3X4GRV
6 X 4 GROOVE	12.0	15.99	MEC4X6GRV

## Munro Threaded Concentric Swage Nipples



Nominal Size in	Length in	Approx. Weight lbs	Model Number
2 X 1 1/2	6.5	1.76	MSNX2X150
3 X 2	8.0	4.51	MSNX3X2
4 X 3	9.0	7.04	MSNX4X3
6 X 4	12.0	15.99	MSNX6X4

## One Piece Flange x Camlock



Approx. Weight lbs	Description	Model Number
6	PART B x Flange – Aluminum 3"	AP330FLBAL
8	PART B x Flange – Aluminum 4"	AP340FLBAL
13	PART B x Flange – Aluminum 6"	AP360FLBAL
4	PART A x Flange – Aluminum 3"	AP330FLAAL
5	PART A x Flange – Aluminum 4"	AP340FLAAL
9	PART A x Flange – Aluminum 6"	AP360FLAAL

## Steel Threaded Flanges

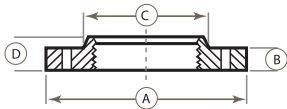

Approx. Weight lbs	Diameter of Flange A	Thickness of Flange B (min.)	Diameter of Hub C (min.)	Length of Hub & Thd. D (min.)	Size in	Model Number
1.7	4.620"	0.500"	2.310"	0.810"	1 1/4	SFBTF1250
2.3	5.000"	0.560"	2.560"	0.880"	1 1/2	SFBTF150
4	6.000"	0.620"	3.060"	1.000"	2	SFBTF200
6	7.000"	0.690"	3.560"	1.120"	2 1/2	SFBTF250
7	7.500"	0.750"	4.250"	1.190"	3	SFBTF300
11.8	9.000"	0.940"	5.310"	1.310"	4	SFBTF400
13.2	10.000"	0.940"	6.440"	1.440"	5	SFBTF500
16.5	11.000"	1.000"	7.560"	1.560"	6	SFBTF600
26	13.500"	1.120"	9.690"	1.750"	8	SFBTF800
37.8	16.000"	1.190"	11.940"	1.940"	10	SFBTF1000
65	19.000"	1.25"	15.00"	1.25"	12	SFBTF1200

ANSI Class 150

## Full Face Fiber Gasket

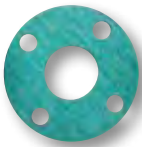

Size in	Model Number
1	MA100FFAG
1 1/4	MA1250FFAG
1 1/2	MA150FFAG
2	MA200FFAG
2 1/2	MA250FFAG
3	MA300FFAG
4	MA400FFAG
5	MA500FFAG
6	MA600FFAG
8	MA800FFAG
10	MA1000FFAG
12	MA1200FFAG

ANSI Class 150

## Full Face Rubber Gasket



Size in	Model Number
1	MA100FFRRG
1 1/4	MA1250FFRRG
1 1/2	MA150FFRRG
2	MA200FFRRG
2 1/2	MA250FFRRG
3	MA300FFRRG
4	MA400FFRRG
5	MA500FFRRG
6	MA600FFRRG
8	MA800FFRRG
10	MA1000FFRRG
12	MA1200FFRRG

ANSI Class 150

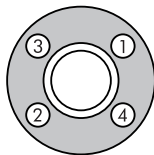

4-Bolt Pattern

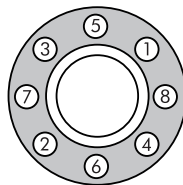

8-Bolt Pattern

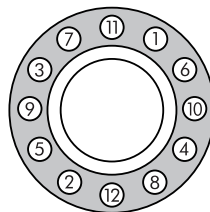

12-Bolt Pattern

Size in	Recommended Torque ft/lbs
1/2	10-15
3/4	
1	
1 1/2	
2	20-30
2 1/2	
3	

Size in	Recommended Torque ft/lbs
4	20-30
6	33-50
8	33-50

Size in	Recommended Torque ft/lbs
10	53-75
12	80-110
14	100



### Did You Know?

Munro has countless flange and flange gaskets for unique & high pressure applications.



### Did You Know?

Tighten bolts following the patterns to the left to ensure even pressure.

# WHY GROOVED FITTINGS?

Over the years we have seen a lot of pump suction and discharges installed. We've also built pump stations with many different types of connections. Based on those experiences, we feel that flexible grooved fittings are a superior system to join pipes, hoses, pumps, and other components of a pumping system. Of course, flanged and threaded connections are important and common connections and we use those as well. But whenever we can, we go grooved.

## How Grooved Fittings Work

Grooved fittings attach via circumferential grooves that are cut or pressed around the end of the pipe, fitting, or other component to be joined. A grooved coupling connection has four elements: grooved end (pipe, fitting, or other component), gasket, coupling housing, and heavy-duty nuts & tracked bolts. The groove is made either by cutting (machining) or rolling (cold-forming). The installed coupling housing encases the gasket and engages the grooves around the pipe to create a leak proof seal in a self-restrained joint. There are two types of grooved coupling; a flexible coupling allows a limited amount of angular movement, and a rigid coupling does not allow movement.

## Comparing Grooved to Other Common Connections

We've already discussed how grooved fittings work, now let's look at where we think the advantages are in a pumping application.

**Threaded fittings** – Inch and a half and smaller threaded fittings are relatively easy to thread correctly. However, when working with two inch and larger, installation can be challenging. The connections almost always have to be cut apart when it's time for service, repairs, or design changes. Threads also create a leak path and great care must be taken to use the appropriate thread sealant to avoid leaks.

**Flanged fittings** – Probably the most common connection in larger pumping applications, flanges avoid the leak issues that you find in the threaded connections. However, with the rigidity innate in a flanged connection, disconnecting a pump for winterization, service, or repair, can be a challenge because vibration or site conditions often cause elements of a system to shift slightly. And if the pump is tough to take out, it's even harder to put it back in.

Munro flexible grooved couplings **make the best connections.**

- Simple to install at all sizes, and leak free when properly installed.
- Simple disconnection and removal of components.
- Offers a few degrees of deflection to realign components when reinstalling.
- Flexible couplings can even address thermal expansion and contraction – a series of flexible couplings can sometimes be used in place of an expansion device.

Because all pumping applications are subject to leaks, thermal expansion and contraction, and changes in site conditions, flexible grooved fittings are the ideal connection. And, since all pumping applications will eventually require components to be removed and reinstalled, flexible grooved fittings are also the most user-friendly connection. We're big believers in going grooved! More questions about Munro Flexible Grooved Piping Systems? Ask our experts!



- **Good for suction**
- **Good for discharge**
- **Good for permanent or temporary applications**
- **Good for your bottom line!**

# Munro Flexible Coupling M7705



Made to USA standards, to easily interchange with other major manufacturers, the Munro flexible coupling is ideal for use in countless piping applications where misalignment might be present. The M7705 can accommodate vibration, thermal stress and moderate seismic activity. This tried and true coupling offers pressure ratings to 500 PSI, depending on pipe size and wall thickness.

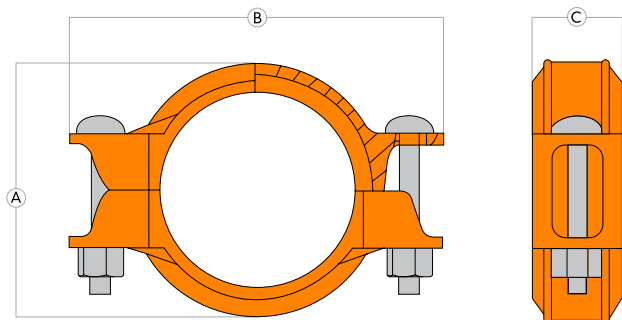

Materials	
Couplings	Ductile iron, non-lead orange rust-inhibiting paint coating, ASTM A536, Grade 65-45-12
Bolts	Carbon steel, heat treated and zinc plated, tensile strength to 110,000 psi: ASTM A 183 Grade 2
Nuts	Carbon steel and zinc plated: ASTM 563 Grade 2
Gaskets	Nitrile, orange color-coded, service temperature: -20°F to 180°F (-29°C to 82°C)



**Did You Know?**  
Find our installation guide on p. 237.

Nominal Size	Pipe OD	Max. Working Pressure (CWP)	Dimensions			Bolts		Approx. Weight	Model Number
			A	B	C	Qty	Size		
in/mm	in/mm	psi/bar	in/mm	in/mm	in/mm		in/mm	lb/kg	
2 50	2.375 60.3	500 35	3.31 84	5.08 129	1.89 48	2	3/8 x 2 1/8 M10 x 55	1.8 0.8	M7705X2
3 80	3.5 88.9	500 35	4.57 116	6.65 169	1.89 48		1/2 x 3 M12 x 75	2.8 1.3	M7705X3
4 100	4.5 114.3	500 35	5.71 145	7.76 197	2.05 52		1/2 x 3 M12 x 75	4.1 1.9	M7705X4
6 150	6.625 168.3	450 31	7.87 200	10.55 268	2.44 62		5/8 x 3 1/2 M16 x 90	6.4 2.9	M7705X6
8 200	8.625 219.1	300 20	10.24 260	13.78 350	2.52 64		5/8 x 3 1/2 M16 x 90	11 4.9	M7705X8
10 250	10.750 273.0	300 20	13.50 343	16.73 425	2.52 64		3/4 x 4 3/4 M20 x 120	16 7.20	M7705X10
12 300	12.750 323.9	300 20	15.35 390	18.39 467	2.52 64		7/8 x 6 1/2 M22 x 165	22.5 10.8	M7705X12

FITTINGS & FLANGES

## Munro Heavy-Duty Flexible Coupling M7707



Made to USA standards, to easily interchange with other major manufacturers, the Munro flexible coupling is ideal for use in countless piping applications where misalignment might be present and a heavy duty coupling is needed. The M7705 can accommodate vibration, thermal stress and moderate seismic activity. This tried and true coupling offers pressure ratings to 750 PSI, depending on pipe size and wall thickness.

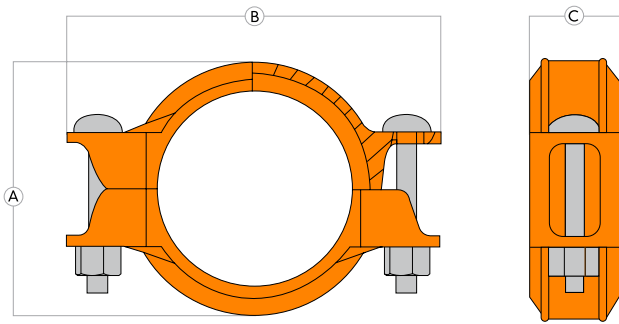

Materials	
Couplings	Ductile iron, non-lead orange rust-inhibiting paint coating, ASTM A536, Grade 65-45-12
Bolts	Carbon steel, heat treated and zinc plated, tensile strength to 110,000 psi: ASTM A 183 Grade 2
Nuts	Carbon steel and zinc plated: ASTM 563 Grade 2
Gaskets	Nitrile, orange color-coded, service temperature: -20°F to 180°F (-29°C to 82°C)



FITTINGS & FLANGES

Nominal Size	Pipe OD	Max. Working Pressure (CWP)	Dimensions			Bolts		Approx. Weight	Model Number
			A	B	C	Qty	Size		
in/mm	in/mm	psi/bar	in/mm	in/mm	in/mm		in/mm	lb/kg	
2 50.8	2.875 73	750 51.71	3.50 88.9	5.35 135.8	1.81 45.9	2	1/2 x 2 3/8 M10 x 60	1.75 0.8	M7707X2
3 76.2	3.5 88.9	750 51.71	4.88 123.9	6.34 161	1.85 46.9		1/2 x 3 M12 x 75	2.9 1.3	M7707X3
4 101.6	4.5 114.3	750 51.71	6.18 156.9	8.03 203.9	2.05 52		5/8 x 3 3/8 M12 x 85	4.2 1.9	M7707X4
6 152.4	6.625 168.3	750 51.71	8.24 209.2	10.75 273	2.09 53		3/4 x 4 3/4 M16 x 120	6.4 2.9	M7707X6
8 203.2	8.625 219.1	420 27.57	10.86 275.8	13.23 336	2.44 61.9		7/8 x 5 M16 x 127	10.8 4.9	M7707X8
10 254	10.750 273.0	400 27.57	13.50 342.9	16.10 408.9	2.56 65		1 x 6 1/2 M20 x 165	15.9 7.2	M7707X10
12 304.8	12.750 323.9	400 27.57	15.35 389.8	18.50 469.9	2.60 66		1 x 6 1/2 M22 x 165	23.8 10.8	M7707X12

# Munro Reducing Coupling M7706



The Munro reducing coupling is ideal for transitioning from one size piping to another. The M7706 is a flexible coupling and can accommodate vibration, thermal stress and moderate seismic activity. This tried and true coupling offers pressure ratings to 500 PSI, depending on pipe size and wall thickness.

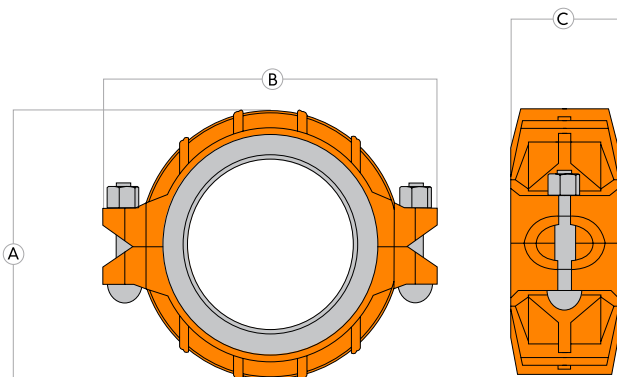

Materials	
Couplings	Ductile iron, non-lead orange rust-inhibiting paint coating, ASTM A536, Grade 65-45-12
Bolts	Carbon steel, heat treated and zinc plated, tensile strength to 110,000 psi: ASTM A 183 Grade 2
Nuts	Carbon steel and zinc plated: ASTM 563 Grade 2
Gaskets	Nitrile, orange color-coded, service temperature: -20°F to 180°F (-29°C to 82°C)



Nominal Size	Larger Pipe OD	Smaller Pipe OD	Max. Working Pressure (CWP)	Dimensions			Bolts		Approx. Weight	Model Number
				A	B	C	Qty	Size		
in/mm		in/mm	psi/bar	in/mm	in/mm	in/mm		in/mm	lb/kg	
2.5 x 2 65 x 50	2.875 73	2.375 60.3	500 35	3.50 88.9	5.35 135.8	1.81 45.9	2	1/2 x 2-3/4 M12 x 76	2.5 1.13	M7706X250X2
4 x 3 100 x 80	4.5 114.3	3.5 88.9	500 35	4.88 123.9	6.34 161	1.85 46.9		5/8 x 3-1/2 M16 x 95	4.15 1.88	M7706X4X3

FITTINGS & FLANGES

## Munro Grooved-end Elbows: 90° Elbow M7110, 45° Elbow M7111



Munro ductile iron grooved fittings are made to USA standards for consistent interchangeability with other major manufacturers.

### Materials

Ductile iron, non-lead orange rust-inhibiting paint coating, ASTM A536, Grade 65-45-12

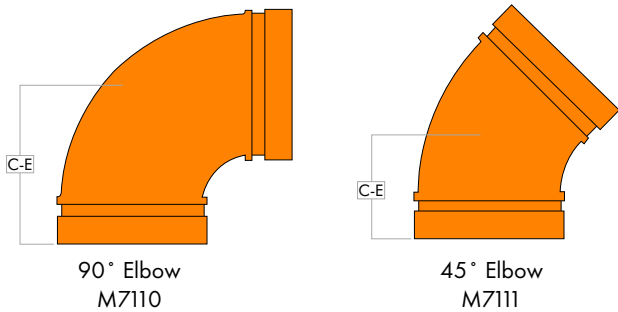

Nominal Size	Pipe OD	90° Elbow M7110		Frictional Resistance *	Model Number	45° Elbow M7111		Frictional Resistance *	Model Number
		C-E	Approx. Wt.			C-E	Approx. Wt.		
in/mm	in/mm	in/mm	lb/kg	ft/mt		in/mm	lb/kg	ft/mt	
2 50	2.375 60.3	3.25 83	1.0 0.5	3.5 1.1	M7110X2	2.00 51	1.0 0.45	1.8 0.5	M7111X2
3 80	3.5 88.9	4.25 108	3.4 1.5	5.0 1.5	M7110X3	2.5 64	2.4 1.1	2.6 0.8	M7111X3
4 100	4.5 114.3	5.0 127	5.8 2.6	6.8 2.1	M7110X4	3.0 76	3.4 1.5	3.4 1.0	M7111X4
6 150	6.625 168.3	6.50 165	13.6 6.2	10.0 3.0	M7110X6	3.5 89	7.8 3.5	5.0 1.5	M7111X6
8 200	8.625 219.1	7.75 197	32 14.5	13.0 4.0	M7110X8	4.25 108	16.2 7.3	6.5 2.0	M7111X8
10 250	10.750 273.0	9.0 229	44 19.95	17.0 5.2	M7110X10	4.75 121	30 13.6	8.3 2.5	M7111X10
12 300	12.750 323.9	10.0 254	68 28.57	20.0 6.1	M7110X12	5.25 133	30 13.6	10.0 3.0	M7111X12

\*Frictional resistance expressed as equivalent feet of straight pipe.

## Munro Grooved-end Tees M7120



Munro ductile iron grooved fittings are made to USA standards for consistent interchangeability with other major manufacturers.

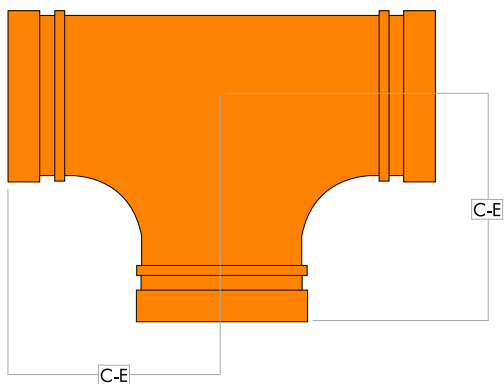

### Materials

Ductile iron, non-lead orange rust-inhibiting paint coating, ASTM A536, Grade 65-45-12



Nominal Size	Pipe OD	Frictional Resistance		C-E	Approx. Weight	Model Number
		Branch	Run			
2 50	2.375 60.3	8.5 2.6	3.5 1.1	3.25 83	2.4 1.0	M7120X2
3 80	3.5 88.9	13.0 4.0	5.0 1.5	4.25 108	6 2.7	M7120X3
4 100	4.5 114.3	16.0 4.9	6.8 2.1	5.00 127	8.2 3.7	M7120X4
6 150	6.625 168.3	25.0 7.6	10.0 3.0	6.50 165	18.9 8.6	M7120X6
8 200	8.625 219.1	33.0 10.1	13.0 4.0	7.75 197	33 14.9	M7120X8
10 250	10.750 273.0	41.0 12.5	17.0 5.2	9.00 229	62 28.1	M7120X10
12 300	12.75 323.9	50.0 15.2	20.0 6.1	10.00 254	81 36.7	M7120X12

\*Frictional resistance expressed as equivalent feet of straight pipe.

## Munro Grooved-end Caps M7160



Munro ductile iron grooved fittings are made to USA standards for consistent interchangeability with other major manufacturers.

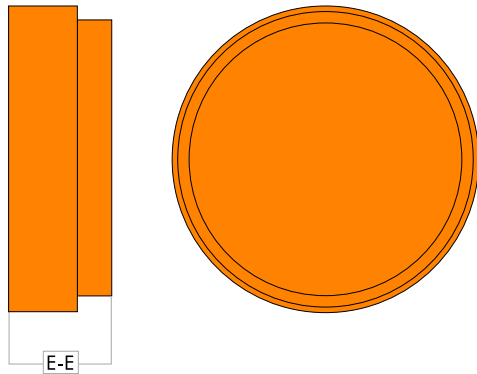

### Materials

Ductile iron, non-lead orange rust-inhibiting paint coating, ASTM A536, Grade 65-45-12



Nominal Size	Pipe OD	E-E	Approx. Weight	Model Number
in/mm	in/mm	in/mm	lb/kg	
2 50	2.375 60.3	1.00 25	0.6 0.27	M7160X2
3 80	3.500 88.9	1.00 25	1.0 0.45	M7160X3
4 100	4.500 114.3	1.00 25	1.4 0.63	M7160X4
6 150	6.625 168.3	1.00 25	5.4 2.45	M7160X6
8 200	8.625 219.1	1.18 30	10.2 4.62	M7160X8
10 250	10.750 273.0	1.25 32	14.0 6.30	M7160X10

## Munro Universal Flange Adapter M7170



This all-in-one universal flange adapter accepts ANSI 125/150, PN10, PN16, JIS, 10K and BS-10E flange patterns. In addition, a longer grooved end makes this unique fitting easier to install.

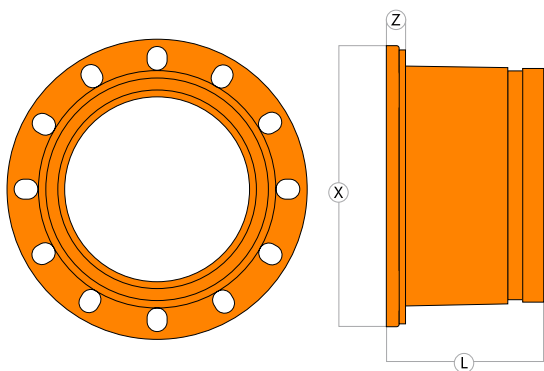

### Materials

Ductile iron, non-lead orange rust-inhibiting paint coating, ASTM A536, Grade 65-45-12

Nominal Size	Pipe OD	ANSI 125/150	PN 10/16	JIS 10K	BS 10E	Dimensions			Bolts		Approx. Weight	Model Number
						L	X	Z	Qty	Size		
in/mm	in/mm	in/mm	in/mm	in/mm	in/mm	in/mm	in/mm	in/mm		in/mm	lb/kg	
10 254	10.75 273	14.25 362	13.75 350	14.00 355	14.00 356	6.00 152	16.00 406	0.80 20.3	12	7/8 22	40 18	M7170X10
12 300	12.75 324	17.00 432	16.15 410	15.75 400	16.00 406	6.00 152	19.00 465	1.00 25.4	12	7/8 22	57 26	M7170X12

## Munro Flange Adapter M7180



The ideal product to transition from flanged to grooved components, this flange adapter is compatible with ANSI Class 125/150.

### Materials

Ductile iron, non-lead orange rust-inhibiting paint coating, ASTM A536, Grade 65-45-12

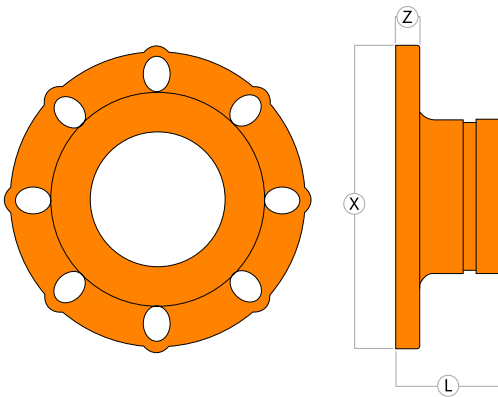

Nominal Size	Pipe OD	ANSI 125/150	Dimensions			Bolts		Approx. Weight	Model Number
			L	X	Z	Qty	Size		
in/mm	in/mm	in/mm	in/mm	in/mm	in/mm		in/mm	lb/kg	
2 50	2.375 60.3	4.75 121	2.50 64	6.50 165	0.63 16	4	5/8 16	3.4 1.5	M7180X2
3 80	3.5 88.9	6.00 152	2.75 70	7.87 200	0.63 16		5/8 16	5.4 2.4	M7180X3
4 100	4.5 114.3	7.50 191	3.00 76	9.00 229	0.63 16	8	5/8 16	7.8 3.5	M7180X4
6 150	6.625 168.3	9.50 241	3.00 76	11.46 291	0.94 24		3/4 20	11 4.9	M7180X6

## Munro Adapter Nipples: Groove x Thread M59, Groove x Weld M58



Munro grooved fittings are made to USA standards for consistent interchangeability with other major manufacturers.

### Materials

Carbon steel, ASTM A733, ANSI B1.20.1

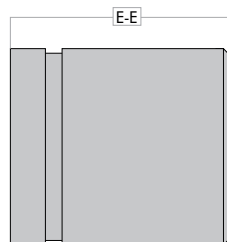

Groove x Weld  
M58

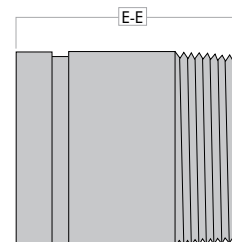

Groove x Thread  
M59

Nominal Size	Pipe OD	M58 Groove X Weld		Model Number	M59 Groove X Thread		Model Number
		E-E	Approx. Wt.		E-E	Approx. Wt.	
in/mm	in/mm	in/mm	lb/kg		in/mm	lb/kg	
2 50	2.375 60.3	--	--	--	4.00 102	1.0 0.4	M59X2X4
3 80	3.500 88.9	--	--	--	4.00 102	2.5 1.1	M59X3X4
4 100	4.5 114.3	6.0 152	4.4 1.9	M58X4X6	6.00 152	4.4 1.9	M59X4X6
6 150	6.625 168.3	--	--	--	6.00 152	7.8 3.5	M59X6X6
8 200	8.625 219.1	6.0 152	13.2 5.9	M58X8X6	--	--	--

## Grooved & Threaded Eccentric Swage Nipples



- Suction pipe size should be one pipe size larger than pump inlet.
- Proper design of suction piping should have a maximum velocity of four to six feet per second.
- Any velocity over eight feet per second may result in damage to the pump.
- Orient the eccentric swage nipple with the flat side up.

Nominal Size in	Length in	Approx. Weight lbs	Model Number
3 X 2 NPT	8.0	4.51	MEC2X3NPT
4 X 3 NPT	9.0	7.04	MEC3X4NPT
6 X 4 NPT	12.0	15.99	MEC4X6NPT
3 X 2 GROOVE	8.0	4.51	MEC2X3GRV
4 X 3 GROOVE	9.0	7.04	MEC3X4GRV
6 X 4 GROOVE	12.0	15.99	MEC4X6GRV

## Munro Mechanical Tee M7721



Outlet couplings, sometimes called mechanical tee or saddle tee, allow you to create a mid-pipe branch outlet quickly and easily. A gasket seals on the joined pipe, in the neck of the outlet. The connection is female threaded. These fittings are not recommended for vacuum applications.

Materials
Ductile iron, non-lead orange rust-inhibiting paint coating, ASTM A536, Grade 65-45-12

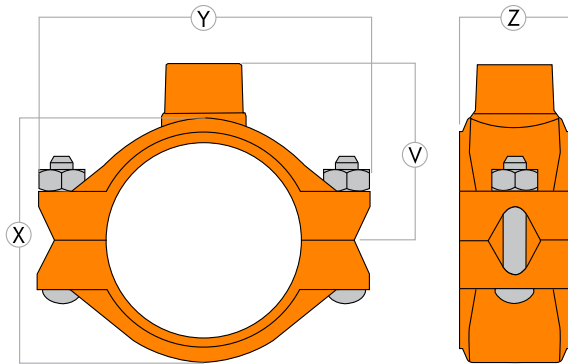

FITTINGS & FLANGES

Nominal Size	Pipe OD	Dimensions				Bolts		Approx. Weight	Model Number
		V	X	Y	Z	Qty	Size		
in/mm	in/mm	in/mm	in/mm	in/mm	in/mm		in/mm	lb/kg	
4 X 2 101	4.5 114.3	3.9 99	2.6 66	7 177	3.8 96.5	2	5/8 16	3.2 1.4	M7721X4X2
6 X 2 152	6.625 168.3	5 127	3.6 91.4	9.75 247.6	4 101.6		3/4 16	6 2.7	M7721X6X2

## Munro Concentric Reducer: M7150 and M7150F



Munro ductile iron grooved fittings are made to USA standards for consistent interchangeability with other major manufacturers. Pressure ratings conform to those of the Munro flexible couplings.

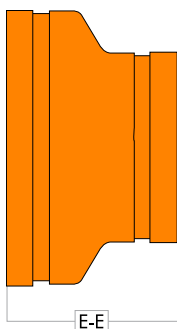

### Materials

Ductile iron, non-lead orange rust-inhibiting paint coating, ASTM A536, Grade 65-45-12



Nominal Size	Pipe OD	Description	Dimensions	Approx. Weight	Model Number
			E-E		
in/mm	in/mm		in/mm	lb/kg	
2 X 1 50 X 25	2.37 X 1.31 60 X 33	Groove X Female NPT	2.5	1	M7150FX2X1
			63.5	0.45	
2 X 1 1/2 50 X 40	2.37 X 1.90 60 X 48		2.5	1	M7150FX2X150
			63.5	0.45	
4 X 2 100 X 50	4.50 X 2.37 114 X 60		3	2	M7150FX4X2
			76	0.9	
6 X 4 150 X 100	6.62 X 4.50 168 X 114		4	6	M7150FX6X4
			102	2.72	
10 X 8 250 X 200	10.75 X 8.62 273 X 219		6	14	M7150X10X8
			152	6.35	
12 X 10 300 X 250	12.75 X 10.75 323 X 273	7	28	M7150X12X10	
		178	12.7		
6 X 2 150 X 50	6.62 X 2.37 168 X 60	Groove X Groove	4	5	M7150X6X2
			102	1.8	
6 X 4 150 X 100	6.62 X 4.50 168 X 114		4	5	M7150X6X4
			102	2.26	
8 X 4 200 X 100	8.62 X 4.50 219 X 114		5	11	M7150X8X4
			127	5	
8 X 6 200 X 150	8.62 X 6.62 219 X 168		5	9	M7150X8X6
			127	4	

## Munro HDPE Transition Coupling M97



Mechanical HDPE transition fittings are an ideal solution to join high density polyethylene pipe with grooved steel pipe.

Munro HDPE transition fittings offer a lighter, easier to handle design with sharp, well-defined teeth for maximum penetration and grip. Engineered to satisfy the working pressure of DR 7.3 to DR 32.5, every Munro HDPE transition fitting uses four high-quality bolts and flanged nuts or washers for improved tightening and holding.

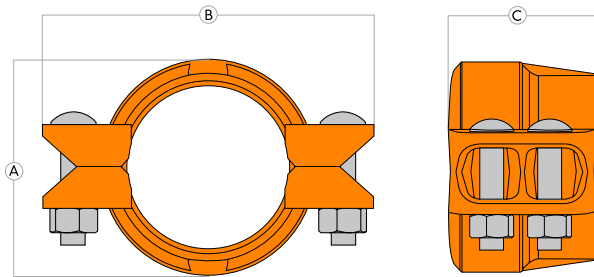

Materials	
Couplings	Ductile iron, non-lead orange rust-inhibiting paint coating, ASTM A536, Grade 65-45-12
Gaskets	Nitrile, orange color-coded, service temperature: -20°F to 180°F (-29°C to 82°C)
Bolts	Carbon steel, heat treated and zinc plated, tensile strength to 110,000 psi: ASTM A 183 Grade 2
Nuts	Carbon steel, zinc plated: ASTM 563 Grade 2
Flanged Nuts	Carbon steel, and zinc plated: ASME B18.2.2-2010. Flanged Nuts have a metric head



**Did You Know?**  
Find our installation guide on p. 235.

FITTINGS & FLANGES

Nominal Size	Pipe OD	Dimensions			Bolts		Approx. Weight	Model Number
		A	B	C	Qty	Size		
in/mm	in/mm	in/mm	in/mm	in/mm		in/mm	lb/kg	
2 50	2.375 60.3	3.125 79.37	5.7 144.78	3.125 79.37	4	3/8 x 2 3/8 M10 x 60	3 1.36	M97X2
3 80	3.5 88.9	4.375 111.12	7.4 187	3.125 79.37		1/2 x 3 M12 x 75	5 2.27	M97X3
4 100	4.5 114.3	5.125 130.17	8.7 220	3.75 95.25		1/2 x 3 M12 x 75	7 3.17	M97X4
6 150	6.625 168.3	6.375 161.95	11.69 296	3.75 95.25		5/8 x 3 1/2 M16 x 90	11 4.99	M97X6
8 200	8.625 219.1	9.5 241.3	14 355	4.25 107.95		5/8 x 3 1/2 M16 x 90	18 8.16	M97X8
10 250	10.750 273.0	11.5 292.1	17.1 434	5 127		3/4 x 4 3/4 M20 x 120	28 12.7	M97X10
12 300	12.75 323.9	14.5 368.3	19.5 495.3	5 127		3/4 x 4 3/4 M20 x 120	35 15.87	M97X12

## Munro HDPE Coupling M95



Mechanical HDPE couplings offer a cost-effective, fast and easy way to join high density polyethylene pipe and fittings.

Munro HDPE couplings are unique! Lighter, easier to handle design with sharp, well-defined teeth for maximum penetration and grip. Engineered to satisfy the working pressure of DR 7.3 to DR 32.5. Uses 4 high-quality bolts and flanged nuts or washers for improved tightening and holding.

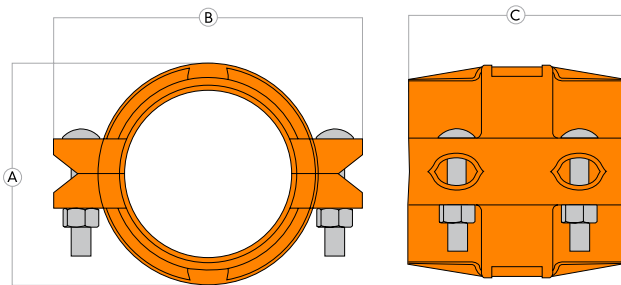

Materials	
Couplings	Ductile iron, non-lead orange rust-inhibiting paint coating, ASTM A536, Grade 65-45-12
Gaskets	Nitrile, orange color-coded, service temperature: -20°F to 180°F (-29°C to 82°C)
Bolts	Carbon steel, heat treated and zinc plated, tensile strength to 110,000 psi: ASTM A 183 Grade 2
Nuts	Carbon steel, zinc plated: ASTM 563 Grade 2
Flanged Nuts	Carbon steel, and zinc plated: ASME B18.2.2-2010. Flanged Nuts have a metric head



**Did You Know?**  
Find our installation guide on p. 233.

Nominal Size	Pipe OD	Dimensions			Bolts		Approx. Weight	Model Number
		A	B	C	Qty	Size		
in/mm	in/mm	in/mm	in/mm	in/mm		in/mm	lb/kg	
2 50	2.375 60.3	2.7 68.58	4.7 119.38	4.6 116.84	4	3/8 x 2 3/8 M10 x 60	4 1.81	M95X2
3 80	3.5 88.9	3.9 99.06	7.10 180	4.6 116.84		1/2 x 3 M12 x 75	7 3.2	M95X3
4 100	4.5 114.3	4.9 124.46	8.40 213	5.75 146.05		1/2 x 3 M12 x 75	9 4.1	M95X4
6 150	6.625 168.3	7.1 180.34	10.30 216	5.85 148.59		5/8 x 3 1/2 M16 x 90	15 6.8	M95X6
8 200	8.625 219.1	9.1 231.14	13.20 335	6 152.4		5/8 x 3 1/2 M16 x 90	21 9.5	M95X8
10 250	10.750 273.0	11.4 289.56	15.90 403	6.5 165.1		3/4 x 4 3/4 M20 x 120	30 13.6	M95X10
12 300	12.75 323.9	14.5 368.3	17.5 444.5	7.25 184.15		3/4 x 4 3/4 M20 x 120	47 21.31	M95X12

FITTINGS & FLANGES

## Munro Nitrile Gaskets for M95



Size	Model Number
2"	MG95X2
3"	MG95X3
4"	MG95X4
6"	MG95X6
8"	MG95X8
10"	MG95X10
12"	MG95X12

## Munro Nitrile Gaskets for M7705 and M97



Size	Model Number
2"	MGX2
3"	MGX3
4"	MGX4
6"	MGX6
8"	MGX8
10"	MGX10
12"	MGX12

Materials	
Gaskets	Nitrile, orange color-coded, service temperature: -20°F to 180°F (-29°C to 82°C)

## Nuts and Bolts



Size	Model Number
1/2" X 3" w/ nut	50X3BOLT
5/8" X 3.50" w/ nut	675X35BOLT
3/4" X 4.75" w/ nut	75X475BOLT
3/8" x 2.125" w/ nut	375X2125BOLT



**Get everything you need!**  
Grooved Check Valves (p. 176) & Butterfly Valves (p.170)

## Mechanical Groove Fittings

	Size in	Description	Approx. Weight lbs	Model Number
	2	Elbow 90° Long Radius	2.5	M7110LRX2
	3		6.5	M7110LRX3
	4		11.5	M7110LRX4
	3	Elbow 45° Long Radius	4.5	M7111LRX3
	4		7.5	M7111LRX4
	2	Elbow 22 1/2°	.5	M7112X2
	4		2.5	M7112X4
	6		5.5	M7112X6
	8		11	M7112X8
	2	Elbow 11 1/4°	.5	M7113X2
	4		2	M7113X4
	6		4.5	M7113X6
	8		8.5	M7113X8
	2x2x1	Tee Reducing Groove	2.5	M7121X2X2
	3x3x2		5.5	M7121X3X2
	4x4x1		10	M7121X4X1
	4x4x2		10.5	M7121X4X2
	8x8x2		35	M7121X8X2
	8x8x4		35.5	M7121X8X4
	8x8x6		37.5	M7121X8X6
	2x2x1	Tee Reducing Groove x Groove x MNPT	2.5	M7121MX2X1
	4x4x1		10	M7121MX4X1
	2	Cross	3.5	M7135X2
	3		8.5	M7135X3
	4		13.5	M7135X4
	2	Check Valve	9	M900X2
	3		11	M900X3
	4		25	M900X4
	6		47	M900X6
	8		66	M900X8
	2	Ball Valve	6.5	M1000X2
	3		13.5	M1000X3
	4		55	M800X4
	6		79	M800X6
	2	Butterfly Valve	4	MBFVGR2
	3		7.5	MBFVGR3
	4		11.5	MBFVGR4
	6		26.5	MBFVGR6

Additional finishes: powder coated, galvanized, stainless steel, brass

Standard gaskets are nitrile – other gaskets available

Choosing the right valve is a critical step in any irrigation project. At Munro, we offer a wide range of valves, including different configurations and construction materials. If you don't see what you need, just give us a call. We know valves!

## VALVE SELECTION BASICS

All valve types have pros and cons, depending on the application. These tips will help you select the appropriate valve.

### Gate Valves

Designed to operate fully open or closed, these valves open slowly and are available in a wide variety of sizes and materials.

Pros:

- Slow operation prevents fluid hammer
- Very little pressure loss
- Good seal under high pressure

Cons:

- Seepage is normal under low pressure

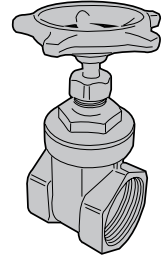

### Ball Valves

These simple, trouble free valves are also designed to operate fully open or fully closed.

Pros:

- Good for throttling clear water
- Low pressure drops
- Open and close quickly
- Simple design and operation

Cons:

- Opening too quickly can cause fluid hammer

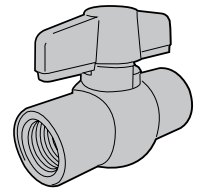

### Butterfly Valves

Generally used for handling large volumes, these valves are very compact.

Pros:

- Can handle large volume
- Can handle slurries
- Compact design

Cons:

- Should not be used for throttling
- Traditional valves need additional hardware to mount

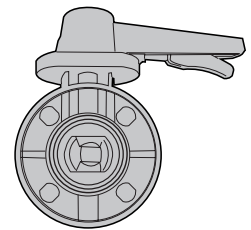

### Globe valves

Used to throttle or limit the flow of water, globe valves are used in situations where the flow needs to be adjusted regularly but does not need to be fully open.

Pros:

- Easy to operate, instant access
- Valve does not need to be resealed

Cons:

- Flow is restricted due to baffle



## Munro Grooved Butterfly Valves



For grooved fitting configurations, this valve is strong and well built.

- Epoxy coated valve body and disk
- Two-piece square stem driver
- Primary and secondary O-ring seals

Size in	Working Pressure psi	Approx. Weight lbs	Model Number
2	175	5.50	MBFVGR2
3		8.10	MBFVGR3
4		13.25	MBFVGR4

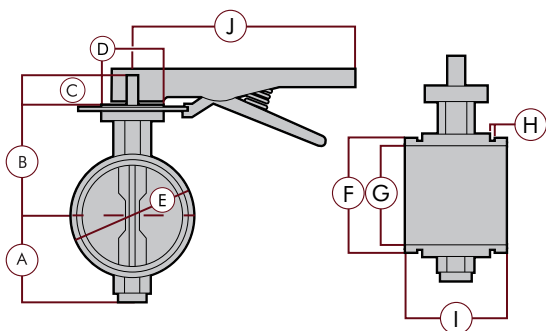

Dimensions in											Model Number
A	B	C	D	E	F	G	H	I	J		
2.40	3.87	1.26	3.03	3.07	2.37	2	.37	3.21	10.5	MBFVGR2	
2.95	4.62	1.26	3.03	4.13	3.5	3	.37	3.85	10.5	MBFVGR3	
3.54	5.38	1.26	3.62	5.20	4.5	4	.37	4.56	10.5	MBFVGR4	

## Munro PVC Butterfly Valves



This economical valve is ideally suited for irrigation flow control using minimal piping space.

- Wafer-style disc improves flow
- Rigid plastic body and disc for dependable chemical resistance inside and out
- EPDM face-seal design requires no additional gaskets between mating flanges
- Handle gives clear indication of disc opening degree

Size in	Working Pressure psi	Approx. Weight lbs	Model Number
2	150	2.9	BFV200
3		3.9	BFV300

## Butterfly Valves for Flange Connections



With forty years of valve experience, Munro understands the demands for a heavy-duty, yet sophisticated valve. This valve features a durable ductile iron body and handle, oil impregnated shaft rings and a ten-position steel disc for easy adjustments.

- Proven construction design – able to withstand the most demanding applications.
- East to install – flexible for multiple applications with holes suitable for ASME flange class 125/150.
- Strong and reliable – one-shaft design improves strength and prevents leakage.

Dimensions in														Model Number
A	B	C	D	E	F	G	H	I	J	K	L	M	N	
3.25	6.25	1.25	2	4.75	4	1.5	2	3	.75	.25	1.5	.4	9.5	BFVMU2WL/LL
3.75	7.25	1.25	3	6	5	1.5	2	3	.75	.25	1.75	.5	9.5	BFVMU3WL/LL
4.5	8	1.25	4	7.5	6.5	2	2.75	3.75	.75	.4	2	.5	10.75	BFVMU4WL/LL
5.5	9	1.25	6	9.5	8.75	2	2.75	3.75	1	.4	2.25	.5	10.75	BFVMU6WL/LL
7	10.25	1.75	8	11.75	10.75	2.75	4	5	1	.5	2.4	.6	15	BFVMU8WL/LL
8	11.5	1.75	10	14.25	13	2.75	4	5	1	.5	2.5	.8	15	BFVMU10WL/LL
9.5	13.25	1.75	12	17	15.75	2.75	4	5	1	.5	3	.8	21.5	BFVMU12WL/LL

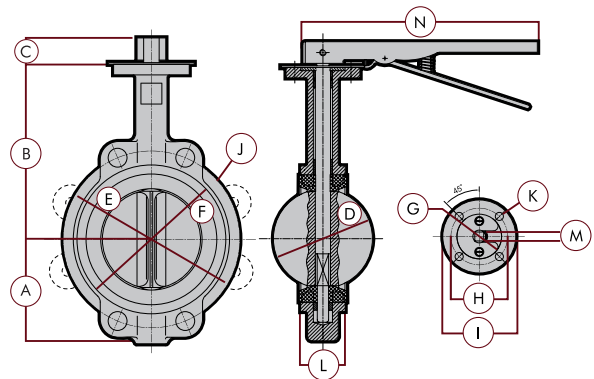

Size in	Disk Material	Rubber Material	Approx. Weight lbs	Working Pressure	Style	Model Number				
2	Ductile Iron	NBR	6.6	150	Wafer Style	BFVMU2WL				
3			9.0			BFVMU3WL				
4			11.9			BFVMU4WL				
6			19.0			BFVMU6WL				
8			32			BFVMU8WL				
10			48.5			BFVMU10WL				
12			80.5			BFVMU12WL				
2			Full Lug			NBR	11.5	150	Full Lug	BFVMU2LL
3							12.8			BFVMU3LL
4							22.0			BFVMU4LL
6	31.1	BFVMU6LL								
8	48.1	BFVMU8LL								
10	70.1	BFVMU10LL								
12	113.0	BFVMU12LL								

Hand wheels also available

Electric and Pneumatic actuators available

# Munro Stainless Steel Irrigation Foot Valves – 2" & 3"



The only foot valve designed specifically for the irrigation industry, these high-quality, spring-loaded foot valves are non-corrosive and available in national pipe thread or PVC slip. With flow velocities similar to the next largest sized valve on the market, this unique product offers unparalleled advantages.

### ADVANTAGES

- Easy to use foot valve features a stainless steel basket strainer
- 1/8" perforations = 3175 microns = 6 mesh
- Excellent flow velocity – 29 holes/sq in. = 33%, open area = 59" total open area
- Repairable valve
- Stainless steel components: assembly bolts, springs, strainer
- Will perform in any position

### Dimensions

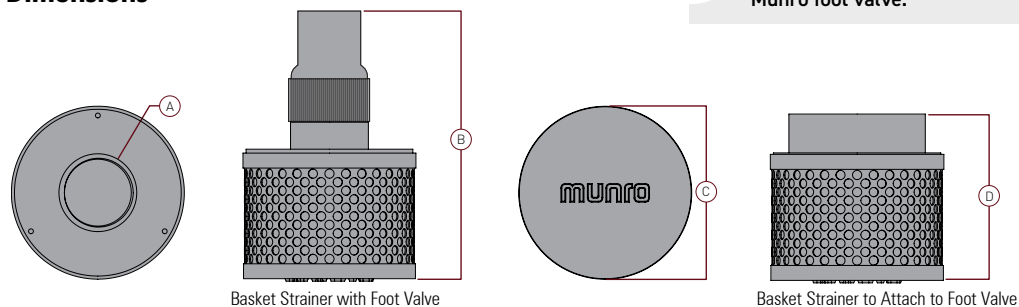

### Did You Know?

If you have a Munro 2" or 3" foot valve, you can purchase our new basket strainer with a flange that will connect directly to your existing Munro foot valve.

	A	B	C	D	Model Number
<b>Basket Strainer with Foot Valve</b>					
SS Basket Strainer 2" Check Slip		10"			MBSA2CVS
SS Basket Strainer 3" Check Slip		12"			MBSA3CVS
SS Basket Strainer 2" Check NPT		10"	7"	--	MBSA2CVT
SS Basket Strainer 3" Check NPT		12"			MBSA3CVT
<b>Basket Strainer to Attach to Foot Valve</b>					
SS Basket Strainer 2" Munro Foot Valve Adapter		--	7"	6.25	MBSA2ADP
SS Basket Strainer 3" Munro Foot Valve Adapter		--		6.75	MBSA3ADP

### Specifications

Size in	Connection Type	Strainer Material	Check Valve Material	Approx. Weight lbs	Model Number
<b>Basket Strainer with Foot Valve</b>					
2	Slip	SS Basket Strainer 2" Check Slip	PVC	4.1	MBSA2CVS
3		SS Basket Strainer 3" Check Slip		7	MBSA3CVS
2	NPT	SS Basket Strainer 2" Check NPT	PVC	4	MBSA2CVT
3		SS Basket Strainer 3" Check NPT		7.15	MBSA3CVT
<b>Basket Strainer to Attach to Foot Valve</b>					
2	Foot Valve	SS Basket Strainer 2" Munro Foot Valve Adapter	--	3.5	MBSA2ADP
3	Thread	SS Basket Strainer 3" Munro Foot Valve Adapter		4.5	MBSA3ADP

See pg. 183 for 2" & 3" NPT basket strainers without foot valve

## Munro PVC Foot Valves – 1 1/4” - 10”



Ideal for quick pump priming, Munro foot valves offer rapid closure to prevent back flow of water. While cast iron foot valves can rust, introducing contaminants, our high quality, non-corrosive PVC foot valve includes stainless steel internal parts for long life and low maintenance.

- All parts are easily replaceable
- Stainless steel components: assembly bolts, springs
- EPDM gasket

Size in	Design	Approx. Weight lbs	Connection Style	Working Pressure psi	Set Up	Model Number	
1 1/4	Spring Loaded	1	Threaded	150	Multi-Positional	FV125T	
1 1/2		1				FV150T	
2		2				FV200T	
3		3 1/2				FV300T	
4		6 1/2				FV400T	
6	Flapper	15	Vertical Only		FV600T		
1 1/4	Spring Loaded	1	Socket Weld		150	Multi-Positional	FV125S
1 1/2		1					FV150S
2		2					FV200S
3		3 1/2					FV300S
4		5 1/2		FV400S			
6	Flapper	15	Flanged	Vertical Only		FV600S	
8		33		FV800F			
10		39		FV1000F			

Replacement parts available.

Dimensions		
A	B	Model Number
2"	6 1/4"	FV125T
3"	8"	FV150T
3"	8 1/4"	FV200T
5 1/2"	11 1/4"	FV300T
7 1/2"	14 1/2"	FV400T
11 1/2"	20"	FV600T
2"	6 1/4"	FV125S
3"	8"	FV150S
3"	8 1/4"	FV200S
5 1/2"	11 1/4"	FV300S
7 1/2"	14 1/2"	FV400S
11 1/2"	20"	FV600S

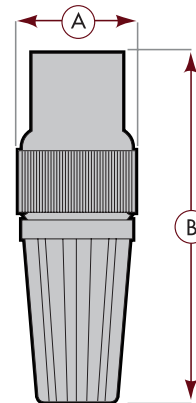

### Did You Know?

Pumps prime faster, better and more efficiently with a Munro Foot Valve!

## PVC Flanged Swing Foot Valves



Complete with a strainer, this flanged foot valve is easy to install and is ideal for large irrigation systems.

- Smooth flow path eliminates pressure loss
- Industrial grade, maintenance free, sealed unit

Pipe Size in	Design	Approx. Weight lbs	Working Pressure psi	Model Number
8	Flapper	33.73	150	FV800F
10		39.02		FV1000F

## PVC Flange



Ideal for easy installation of foot valves or strainers, the Munro PVC flange is heavy duty and non-corrosive.

- 125 lb class flange
- Resistant to most chemicals

Pipe Size in	Holes	Approx. Weight lbs	Working Pressure psi	Model Number
8	8	6.28	150	FVP08
10	12	10.03		FVP10
12	12	17.53		FVP12

## Cast Iron Foot Valves



These valves are an economical option for use in irrigation projects, drainage on construction sites and pumping from ponds and streams.

- Sturdy cast iron construction, complete with strainer
- Leather flapper check to retain prime

Pipe Size in	O.D. Valve Leather	Approx. Weight lbs	Model Number
1 1/2	3"	3.0	FV3TFV150
2	4 1/4"	5.5	FV3TFV200
2 1/2	4 1/2"	7.3	FV3TFV250
3	5 3/4"	10.8	FV3TFV300
4	7"	19.5	FV3TFV400
6	10 1/8"	47	FV3TFV600
8	12 7/8"	97	FV3TFV800

Weights and leathers available.

## Brass Foot Valves



This valve is a must-have to retain prime in domestic irrigation applications.

- Stainless steel springs
- Tapered stainless steel screen & cap
- Non-corrosive delrin stem guide

Size in	Working Pressure psi	Approx. Weight lbs	Model Number
1/2	200	1/4	FV2T
3/4		1/2	FV3T
1		3/4	FV4T
1 1/4		1 1/4	FV5T
1 1/2		1 1/2	FV6T
2		3	FV8T
3		7 1/2	FV12T

## Brass Gate Valves

Brass gate valves are an economical valve to stop flow in an irrigation system, these can also be used to isolate zones.

- Full port, 200 lb CWP
- Screwed in bonnet



Size in	Working Pressure psi	Approx. Weight lbs	Model Number
3/8	200 WOG	.68	GV375T
1/2		.55	GV050T
3/4		.68	GV075T
1		1.0	GV100T
1 1/4		1.44	GV125T
1 1/2		2.2	GV150T
2		3.3	GV200T
2 1/2		6.6	GV250T
3		7.2	GV300T
4		13.75	GV400T

Also Available with Rising Stem

## Ductile Iron Flanged Open Gate Valves

This industrial style valve allows full flow. This is a durable, rugged valve.

- 250 PSI non-shock CWP
- Stainless steel stem and bonnet
- Meets AWWA C515



Size in	Working Pressure psi	Approx. Weight lbs	Model Number
2	150	32	GV200IF
3		52.9	GV300IF
4		73.9	GV400IF
6		149.9	GV600IF
8		214.9	GV800IF
10		335.1	GV1000IF
12		478.4	GV1200IF
14		866	GV1400IF
16		1224	GV1600IF

Also available in OS&Y configuration. Class 300 and above also available.

## Quick Opening Knife Gate Valves

When full flow and quick stoppage is a must, this is an ideal product. Designed to allow full flow under low pressure, this valve is primarily used in septic tank truck and water transfer applications.

- Heavy cast bronze body
- Quick action open and close
- Lever handle split wedge disc



Size in	Working Pressure psi	Approx. Weight lbs	Model Number
3	200	8.2	GV3QUICK
4		13.2	GV4QUICK
6		23.4	GV6QUICK

## Full Port Brass Ball Valve - 600 WOG

A great option for countless irrigation applications, this valve is suitable for various liquids and gases.



Size in	Maximum Pressure psi	Approx. Weight lbs	Model Number
1/4	600 WOG	.37	BAV754T01N
3/8		.37	BAV754T02N
1/2		.51	BAV754T03N
3/4		.66	BAV754T04N
1		1.15	BAV754T05N
1 1/4		1.78	BAV754T06N
1 1/2		2.38	BAV754T07N
2		3.06	BAV754T08N
2 1/2		6.13	BAV754T09N
3		8.17	BAV754T10N
4		7.10	BAV754T11N

Also available in 3-way configuration

## 1/4" Munro Ball Valve



1/4" male x Female, Short Handle Ball Valve.

Size in	Working Pressure psi	Approx. Weight lbs	Quantity	Packaged for Easy Display	Model Number
1/4	300	.15	1	No	BAVSH25
		.30	2	Yes	BAVSH25X2

## Stainless Steel Ball Valve



Used in high pressure or chemical applications.

Size in	Working Pressure psi	Approx. Weight lbs	Model Number
1/4	1000 WOG	.58	BAV949161
1/2		.63	BAV949163
3/4		1.27	BAV949164
1		1.63	BAV949165
1 1/4		3.06	BAV949166
1 1/2		4.04	BAV949167
2		6.05	BAV949168

## Polypropylene Ball Valve



When a ball valve is desired, polypropylene is an economical option. Inert to most chemicals, this full port valve can be used in many applications.

Size in	Working Pressure psi	Approx. Weight lbs	Model Number
1/2	100 @ 75°F	.75	BV4011A20
3/4		.71	BV4011B20
1 1/4		2.08	BV4011X20
1 1/2		2.04	BV4011D20
2	75 @ 150°F	3.5	BV4011N20
2 1/2		4.25	BV4011W20
3		6.0	BV4011Z20

## Munro PVC & Stainless Steel Ball Valve



A stainless steel handle and ball and EPDM o-ring makes this economical valve easy to operate and long lasting. Connection is NPT.

Size in	Working Pressure psi	Approx. Weight lbs	Model Number
1/2	235	.22	BV050
3/4		.29	BV075
1		.46	BV100
1 1/4		.71	BV125
1 1/2		.90	BV150
2		1.85	BV200

## PVC Ball Valve



A must for any irrigator's toolbox, this is an easy-to-install, threaded, economical valve.

Size in	Working Pressure psi	Approx. Weight lbs	Model Number
1/2	150 @ 73°F	.22	BAV050PVC
3/4		.44	BAV075PVC
1		.69	BAV100PVC
1 1/4		.90	BAV125PVC
1 1/2		1.19	BAV150PVC
2		1.86	BAV200PVC

## PVC Check Valve



Our union-style check valve is easy to disassemble and clean, and threaded for easy installation.

Size in	Length in	Working Pressure psi	Approx. Weight lbs	Model Number
1.5	6 5/8	150 @ 73° F	1.08	CV150
2	7 1/8		1.32	CV200
3	10		3.51	CV300

## Brass Check Valve



Ideal for a domestic water submersible pump application, this valve can be used vertically or horizontally.

- Stainless steel springs
- Resilient washer holds disc in place.

Size in	Working Pressure psi	Approx. Weight lbs	Model Number
1/2	200 WOG	.75	CV2T
3/4		1	CV3T
1		1.25	CV4T
1 1/4		2	CV5T
1 1/2		2.25	CV6T
2		3.75	CV8T
3		8.5	CV12T

## Brass Swing Check Valve



This valve features a screw cap for easy clean out. A hinge-style flapper allows easy low pressure opening and operation. The metal disc makes this suitable for water, oil and gas.

Size in	Working Pressure psi	Approx. Weight lbs	Model Number
1/2	200 WOG	.42	SCV521T03
3/4		.58	SCV521T04
1		.73	SCV521T05
1 1/4		1.33	SCV521T06
1 1/2		1.83	SCV521T07
2		2.83	SCV521T08
3		11.63	SCV521T10
4		15.25	SCV521T11

## Sump and Sewage PVC Check Valve



Used in sewage applications where full flow is needed utilizing compression gaskets to connect IPS pipe.

Size in	Solids Handling in	Length in	Diameter in	Approx. Weight lbs	Model Number
1 1/2	1 1/2	7 1/2	3 1/4	1	SRPW2123
2	2	9 3/4	4 1/4	1.75	SRPW2124
3	3	14	5 3/4	5	SRPW2125

## Globe Style Silent Check Valve



Silent check valves retain the integrity of the pipe by reducing shock and water hammer.

- Cast iron body
- Bronze seat, disc and bushing
- Stainless steel spring

Size in	Temperature	Working Pressure psi	Approx. Weight lbs	Model Number
2 1/2	180°F	200	24	CV2240T
3			29	CV2241T
4			42	CV2242T
5			52	CV2243T
6			73	CV1806
8			126	CV1808
10			205	CV2247T
12			306	CV2248T
14			380	CV2249T
16			501	CV2250T

\*Other materials available.

## Ball Check Valve



Our ball check valves are made of corrosion resistant PVC and have self-cleaning balls and easy access ports. Available threaded or socket weld for easy gluing to PVC pipe.

Size in	Maximum Temp.	Working Pressure psi	Approx. Weight lbs	Model Number
1 1/4	180°F	100	1	BCV2132T
1 1/2			2	BCV2133T
2			2	BCV2134T

## Wafer Check Valve



This economical, space saving valve allows for easy flow access and can be used in a vertical or horizontal installation.

Size in	Dimension "A" in	Dimension "B" in	Working Pressure psi	Approx. Weight lbs	Model Number
2	4.1	2.125	150	6.5	WCVC200
3	5.4	2.25		11	WCVC300
4	6.9	2.5		13	WCVC400
6	8.7	3		22	WCVC600
8	11	3.75		42	WCVC800

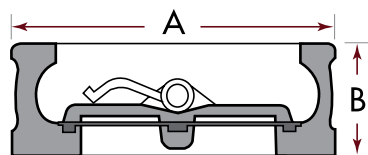

## Discharge Check Valve



Cast iron discharge valve bolts directly to pump for priming and pump protection. The valve comes with automatic, spring activated mechanism with external handle.

Description	Approx. Weight lbs	Model Number
2 1/2" Thread x 3" Thread	21	BEB05922
3" Flange x 4" Thread	20	BEB05923
4" Flange x 4" Thread	36	BEB05924
5" Flange x 5" Thread	55	BEB05925
6" Flange x 6" Thread	70	BEB05926

## Float Valve Kits



No need to spend time choosing the individual parts and pieces – we've done it for you in this light weight, high quality, corrosion resistant kit.



Size in	Rod Length in	Thread Size in	Ball Size in	Working Pressure psi	Approx. Weight lbs	Model Number
3/4	8	1/4	5	150 PSI @ 73° F	.51	FLT075T
1			6		.93	FLT100T
1 1/4	12	7/16	10		2.2	FLT125T
1 1/2			12		2.2	FLT150T
2	18		12	4.19	FLT200T	
3			15	18.74	FLT300T	
				100 PSI @ 73° F		

## Brass Float Valves



Used for tank measurement and flow control when electricity is not present or practical. Countless applications include stock tanks, vaults and ponds.

Pipe Size in	Fitting Stem	Flow Cap. at 100 psi	Working Inlet Pressure psi	Recom. Float Diameter in	Approx. Weight lbs	Model Number
3/8	1/4 x 20 x 10	21	240	6	.54	FLV375
1/2	1/4 x 20 x 10	31	210	6	.71	FLV500
3/4	1/4 x 20 x 10	60	150	6	1.14	FLV750
1	5/16-18 x 12	150		8	1.81	FLV1000
1 1/4	3/8-16 x 12	347		8	3.16	FLV1250
1 1/2	3/8-16 x 12	346		8	3	FLV1500
2	3/8-16 x 12	357		8	3.35	FLV2000

Available in 3/8" – 3" in PVC



**Did You Know?**  
Float valves up to 3" are available!

## Floats



Diameter in	Threaded Connection	Material Construction	Approx. Weight lbs	Model Number
6	1/4 - 20	Plastic	7.3	FBP6
8	3/8 - 16		12.6	FBP8
7	5/16 - 18		12.6	FBP87
5	1/4 - 20	Copper	6.5	FBC5
6	1/4 - 20		8.3	FBC6
8	3/8 - 16		20	FBC8



**Did You Know?**  
Not sure which valve you need? Give us a call. We're here to help!

## Stems



Thread Size in	Rod Diameter in	Length in	Approx. Weight lbs	Model Number
1/4 - 20	1/4	10	2	FLV11
5/16 - 18	5/16	12	2	FLV12
3/8 - 16	3/8	12	2	FLV13

## Flow Control Valve



To prevent over-pumping of low yields the flow control valve is used primarily in submersible pump and flow control applications. These valves are self-cleaning and designed to deliver a constant volume of water over a wide pressure drop range.

Available from 3/8" to 1 1/2" at various flows.

## PVC Air Evacuating Valves



Maximizing operating efficiency by evacuating air from the piping system, this valve is specifically designed for piping systems with slope changes and large sections.

Size in	Set Up	Working Pressure psi	Approx. Weight lbs	Model Number
1/2	Threaded	150	.46	ARV050T
3/4			ARV075T	
1			ARV100T	
1 1/4			ARV125T	
1 1/2			ARV150T	
2			ARV200T	
2 1/2			ARV250T	
3			ARV300T	
4			ARV400T	
4			5.31	

## Unloader Valves



Intended for clean water applications with roller or piston pumps, these higher pressure valves are used to relieve pressure.

Outlet/Inlet (NPT)	Number of Ports	Max. Temp.	Max. gpm	Adjustable psi	Approx. Weight oz	Model Number
3/8"M x 3/8"M	2	200°F	5	300-600 400-1000 800-1500	8	HPP33900062D HPP33900063D HPP33900067D

## Adjustable Relief Valves



Outlet/Inlet (NPT)	Min psi	Max psi	Materials	Approx. Weight lbs	Model Number
1/2"F x 1/2"M	15	200	Cast bronze body, s.s. ball valve	1.25	HPP33000002
3/4"F x 3/4"M	15	300		1.25	HPP33000001
1 1/4"F x 1 1/4"M	15	200	Cast iron body, s.s. ball valve	3.5	HPP33160002

## Pre-set Relief Valves



Size in	Pressure Relief Setting psi	Approx. Weight lbs	Model Number
1/2"M x 1/2"F	75	.330	RV16202
3/4"M x 1/2"F		.375	RV16203

## 2" Munro Y-Strainer



- Easy removable cap for fast cleaning
- Corrosion-resistant buna rubbers and polypropylene and glass-filled nylon components

- Tough Reinforced 316 stainless steel screen available in mesh sizes of 6, 14, 30 or 80
- High capacity flow
- Low pressure loss, 100 PSI Maximum

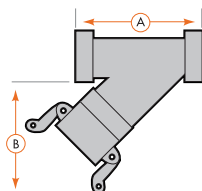

Thread Size in	Dimensions in		Screen Mesh	Hole Size (approx.) in	Approx. Weight lbs	Model Number
	A	B				
2	8.5	9.5	80	.0070	4	BV200A80
			30	3/32		BV200A30
			14	1/16		BV200A14
			6	3/16		BV200A6

O-RING

Replacement screens available

## 2" Munro Deluxe Y-Strainer



The Munro Deluxe Y-Strainer offers all the features of the standard Y-Strainer, with the addition of an aluminum screen cover and a ball valve for quick flushing. The ball valve can be replaced with a solenoid for automatic flushing.

- Filter area screen: 68 sq. in.
- Flows up to 75 GPM
- 100 PSI @ 70° F

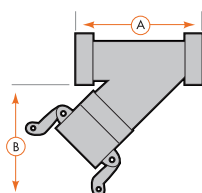

Thread Size in	Dimensions in		Screen Mesh	Hole Size (approx.) in	Approx. Weight lbs	Model Number
	A	B				
2	8.5	11	80	3/32 1/16	5	MS20080
			30			MS20030
			14			MS20014
			6			MS2006

O-RING

Replacement screens available

## 3" Munro Y-Strainer



Threaded End Cap

- Heavy duty, high capacity
- Extra large stainless steel screen for high capacity flow
- Precision molded glass – reinforced co-polymer
- 4" dust cap with patented safety latch

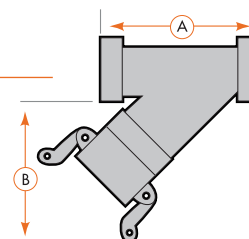

Cam Fitting

Dimensions in		PSI Max at 70° F	Screen Mesh	Hole Size (approx.) in	Thread Size in	Approx. Weight lbs	Model Number
A	B						

**With Thread on Cap** - (6 and 40 mesh available upon request)

12	8	70	20	1/32	3	8	BV300A20
			12	1/16			BV300A12

O-RING

**With Cam Fitting Clean Out**

12	13	70	20	1/32	3	16	MS300A20
			12	1/16			MS300A12

O-RING

Replacement screens available

## T-Line Strainers & Replacement Screens



Size in	Mesh Size	Description	Max psi	Max Temp.	Model Number
1/2	20 Mesh	Strainer	100	70° F	BVLST05020
1/2	40 Mesh				BVLST05040
1/2	80 Mesh				BVLST05080
3/4	20 Mesh				BVLST07520
3/4	40 Mesh				BVLST07540
3/4	80 Mesh				BVLST07580
1	20 Mesh				BVLST10020
1	40 Mesh				BVLST10040
1	80 Mesh				BVLST10080
1/2 to 1	20 Mesh	Screen			BVLST51220
1/2 to 1	40 Mesh		BVLST51240		
1/2 to 1	80 Mesh		BVLST51280		

## Y-Strainer Replacement Screens



Size in	Screen Mesh	Approx. Weight oz	Model Number
2	6	5	BVP4S50806
	14		BVP4S50814
	30		BVP4S50830
	40		BVP4S50840
	80		BVP4S50880

## Hardware Cloth Mesh Strainer



Munro strainers are made of galvanized 1/8" hardware cloth for suction screening and may be easily folded and clamped to pipe.

Mesh	Description	Dimensions in	Approx. Weight oz	Model Number
8	Galvanized 1/8" Hardware Cloth	12 x 3.75	2.4	MS1001

## Mesh Screen Reference Chart

What does mesh size mean? Figuring out mesh sizes is simple. Count the number of openings in one inch of screen. The number of openings is the mesh size. So a 4-mesh screen means there are four little squares across one linear inch of screen. A 100-mesh screen has 100 openings, and so on. As the number describing the mesh size increases, the size of the particles decreases. Higher numbers equal finer material. Mesh size is not a precise measurement of particle size. See page 213 for a Particle Size Table.

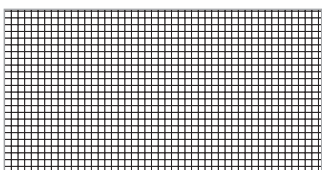

**20 Mesh**  
49% O.A.  
0.035" Openings

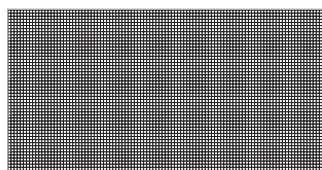

**40 Mesh**  
41% O.A.  
0.016" Openings

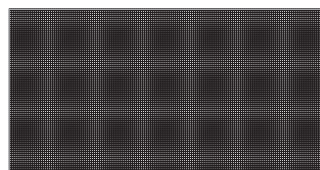

**60 Mesh**  
38% O.A.  
0.010" Openings



**80 Mesh**  
36% O.A.  
0.008" Openings

# Munro Stainless Steel Basket Strainers



Basket Strainers can be used with all makes of centrifugal pumps. An "open" area up to 50% allows strainers to filter out large damaging debris, yet permits sufficient water passage to keep pumps functioning at full capacity.

Thread Size in	Hole Size in	Height in	Diameter in	Approx. Weight lbs	Model Number
-------------------	-----------------	--------------	----------------	-----------------------	-----------------

Munro Stainless Steel Irrigation Basket Strainers

2	1/8	5.83	7	2.9	MBSA2
3		6.08		3.25	MBSA3

Zinc Plated Steel Basket Strainers

1	3/16	6 1/4	1 3/4	.25	SPLG0100
2	3/8	6 3/4	2 3/4	.6	SPLG0200
3	3/8	9 3/4	4	1.5	SPLG0300
4	3/8	9 3/4	5	2.0	SPLG0400
1 1/2	3/8	3 3/4	5	1.5	AP3TRHS150
2	3/8	4	6	2.0	AP3TRHS200
2 1/2	3/8	3 1/2	6	2.5	AP3TRHS250
3	3/8	5	7	4.0	AP3TRHS300
4	3/8	4 1/2	7	5.0	AP3TRHS400
8	1	11	11	22.0	AP3TRHS800
1 1/4	3/8	4 1/4	5	1.0	SPRD0125
3	1	3 3/4	7	3.0	SPSQ300100
10	1/2	15	12	26.0	BS10

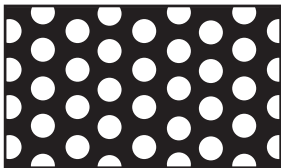

1/8"

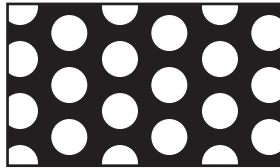

3/16"



3/8"



1/2"



1"

INDUSTRIAL GOODS

## Munro PVC Basket Strainers



Designed to protect your pump system for the long haul in moderately dirty water, the Munro PVC Basket Strainers will keep grass clippings, algae, and other water-borne debris from clogging the pump and sprinkler system components.

- Corrosion-free 6-mesh PVC screen is more durable than steel
- With five sizes available, there is a strainer to fit all but the largest pump systems

Intake Size in	Total Height in	Outside Dia. in	Surface Area sq. in	Approx. Weight lbs	Model Number
2	10	10.25	471	4.8	MBSB200
3	10		471	5.5	MBSB300
4	5		314	4.8	MBSB400
4	10	15	825	5	MBSB400L
6	12		919	5.5	MBSB600

## Munro Self-Cleaning PVC Basket Strainers



Pressurized spray nozzles, rotating inside the Munro Self-Cleaning Strainers, are designed to combat the natural tendency of trash to collect around the exterior of a strainer while a pump is running. Self-cleaning strainers keep pumps working longer with less opportunity to clog in high-particulate or dirty water.

- Keeps water-borne debris from being drawn into irrigation systems
- Self-cleaning mechanism with brass nozzles and bearings
- Durable 6-mesh PVC screen
- Easy disassembly for cleaning and maintenance

Intake Size in	Total Height in	Outside Dia. in	Screen Mesh sq. in	Max Recomm. Output	Flush Line Demand at 40 PSI	Approx. Weight lbs	Model Number
2	10	10.25	240	70 GPM	5 GPM	6.6	MBSC200
3	12	15	305	105 GPM	6.5 GPM	8	MBSC300
4	12		540	170 GPM	10 GPM	12.5	MBSC400

### How it works

Munro Self-Cleaning PVC Strainers work by taking a small amount of the pressurized water generated by the pump and supplying this back to the strainer through a return line. The pressurized water drives the rotation of two internal flat-fan nozzles, which clean off any debris that may accumulate on the screen. The natural tendency for trash and debris to be drawn onto the screen by the pump's suction is counteracted by the internal washing mechanism. The placement, size, and orientation of the nozzles are designed to maximize the cleaning capability for the amount of water used. Munro Self-Cleaning PVC Strainers are easily disassembled for cleaning and maintenance.

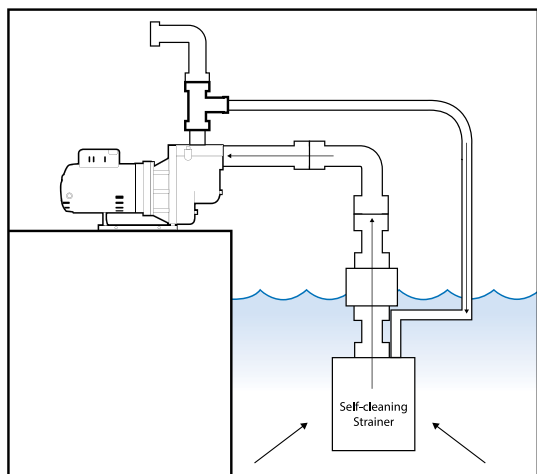

#### Did You Know?

It is a good idea to install a strainer on the flush line to keep spray heads clean.

## Pressure Gauges



### Dry Gauge – bottom mount

To indicate pressure above atmospheric. Usable on air, oil, gas, water or any other pressure medium which does not attack bronze. Install protective siphon when used on steam.

Connection Size in	Dial Size in	Description	Pressure Range psi	Approx. Weight lbs	Model Number
1/4 Bottom	2 1/2	Dry Gauge with Brass Tube & Socket	0-15	.3	MUGAUGE15D
			0-30		MUGAUGE30D
			0-60		MUGAUGE60D
			0-100		MUGAUGED
			0-160		MUGAUGE160D
			0-200		MUGAUGE2D
			0-300		MUGAUGE3D
			0-400		GAG14458
			0-600		GAG14459
			0-1000		GAG14461

Pressure Gauge dial range should be twice the intended operating pressure range.



### Liquid Filled – bottom mount

For severe service requiring a waterproof, steam-proof or weatherproof gauge, with the added problems of pulsation and vibration. Gauge has shock absorbing Polyglide movement plus liquid filling to absorb effect of vibration and pulsation.

Connection Size in	Dial Size in	Description	Pressure Range psi	Approx. Weight lbs	Model Number
1/4 Bottom	2 1/2	Liquid Filled with Brass Tube & Socket	30" Vac.	.5	MUGAUGEVAC30
			30"x30#		MUGAUGEVAC30X30
			30"x100#		GAJ1008AL
			0-15		MUGAUGE15
			0-30		MUGAUGE30
			0-60		MUGAUGE60
			0-100		MUGAUGE
			0-160		MUGAUGE160
			0-200		MUGAUGE200
			0-300		MUGAUGE300
			0-400		MUGAUGE400
			0-600		MUGAUGE600
			0-1000		MUGAUGE1000
			0-2000		MUGAUGE2000
			0-3000		MUGAUGE3000
			0-5000		MUGAUGE5000

Pressure Gauge dial range should be twice the intended operating pressure range. Also available: Back mount and panel mount. Various sizes and accuracies.



**Did You Know?**  
For 1/4" isolation valve see p. 178

## Munro Centrifugal Pump Pressure Gauge Kit



Gauges are a great indicator of how your pump system is working. This assembly makes installing a gauge a one-piece operation instead of three. Saving time equals saving money!

Pressure Gauge	Bell Reducer	Riser	Model Number
0-100 psi Liquid Filled 1/4" Bottom Mount	3/4" x 1/4"	4" Galvanized	CPGKIT

## Standard Gauge Dampener



Prolongs gauge life.

Stem Size NPT in	Approx. Weight oz	Model Number
1/4 M x 1/4 F	2	HPP2404-0047

## Centrifugal Pump Stand

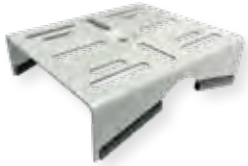

A steel, grey powder-coated, universal centrifugal pump stand.

Dimensions in	Approx. Weight lbs	Model Number
9 W x 7 1/2 D x 3 1/2 H	2.9	TPPMBI

## Controlled Air Water System Tanks



- All butyl water chamber • Appliance-like finish • Every tank pressure tested
- Sizes to 119 gallons • 5 Year warranty

Connection Size in	Dimensions Diameter x Height in	Total Volume Gallons	Maximum Operating Pressure psi	Approx. Weight lbs	Model Number
3/4	11 x 14.75	4.6	100	10	TPAT15
1	15.375 x 24.75	14		29.5	TPAT44
1	15.375 x 32.25	20		35	TPAT66
1	20 x 38.625	36		55	TPAT111/122
1 1/4	23.375 x 38.625	52		66	TPAT144
1 1/4	23.375 x 46.375	65		102	TPAT211
1 1/4	23.375 x 59	86		131	TPAT266/244
1 1/4	26 x 61.25	119		160	TPAT366

AT25H, 44H Horizontal Tank With Integral Pump Stand

Tank Performance Chart

Pressure Switch Setting	AT6	AT15	AT25	AT44	AT66	AT111	AT144	AT211	AT266	AT366
20/40	0.8	1.7	3.1	5.2	7.4	11.8	16.3	22.9	31.5	43.6
30/50	0.7	1.4	2.6	4.3	6.2	9.9	13.6	19.2	28.4	36.8
40/60	0.6	1.2	2.3	3.8	5.4	8.6	11.9	16.7	23.0	32.1

## Tank Fitting Packages



- Tank Tee • Pressure Gauge • 1" or 1 1/4" Brass or PVC • Pressure Switch • Relief Valve

Size in	Description	Approx. Weight lbs	Model Number
1	Cast Bronze	4	TP100B
1 1/4	14" Cross Fabricated	4	TP125BF
1 NPT x 11	11" PVC Tee	1	TT1X11

## Air Chargers (Snifter Valves)



Size in	Length in	Type of Cap	Approx. Weight oz	Model Number
1/8	7/8	Vented	.5	MA940006
1/4	1	Solid		MA940009

## Open End 9/16" Wrench



Size in	Overall Length in	Open End Width in	Open End Thickness in	Approx. Weight oz	Model Number
9/16	5 3/4	1 5/32	13/64	2.3	JHW1136

**Boots**

Steel toe boots available in ozone and tear resistant rubber or full-grain leather. Available in whole sizes 3-15 (rubber) and 7-12, 13, 14M; 8-12, 13W (leather).

**Ear Protection**

Disposable foam earplugs rated at 29 dB Noise Reduction Rating (NRR) or a muff style protection with 26 dB NRR available.

**Safety Vests**

These lime-colored vests come in a wide variety of sizes from Small to 5XL.

**Respirators**

Half face-piece with changeable cartridges in small, medium or large.

**Tie-Downs**

Ratchet lock hi-test webbing with a working load limit of either 500 or 3,333 lbs.

**Support Harnesses**

Nylon full body harness with pass-thru leg buckles available in medium through 2XL.

**Hard Hats**

Comfortable, lightweight protection consisting of a polyethylene shell. Available in sizes 6 ½ through 8.

**Rain Gear**

Made from PVC and nylon, the flame resistant bib and jacket are available in sizes S to 6XL.

**Gloves**

Available in nylon (size 6-10), cowhide leather (size small-2XL) and PVC (size L) for a variety of applications, wet or dry.

**Safety Glasses**

Low-cost, basic eye protection to more comfortable upgraded options with UV protection available.

**Cut-off Saw Blades**

Metal cutting circular saw blades with different configurations to cut through steel, stainless, aluminum, thin steel and steel studs.

**Sledgehammers**

Ten and 12 pound hammers for heavy demolition feature a 36 inch rubber gripped fiberglass handle.

**Drill Bits**

Use for routine maintenance, repair work, rethreading, cutting internal threads in pipes or drilling – taper, bottoming or high speed styles.

**Spill Pads**

Available in oil only or universal sorbents, these spill pads can absorb oil and petroleum products, water and chemical based fluids.

**Sealants**

Slow drying, soft setting pipe thread sealants which can be used on a variety of materials, including: steel, iron, brass, aluminum, stainless steel and PVC.

**Hand Cleaners**

Wipes used to remove oil, grease, grime, stains and other materials.

**Rivet Gun/Rivets**

Hand held rivet guns make joining metal together a snap. Stainless steel rivets also available. Limited sizes.

**Did You Know?**

Munro stocks and sources 1000's of items – ask us!

# Munro Freeze Defeat



## Munro guards your pump from freezing weather!

Is your pump ready for winter? Try Freeze Defeat, the NEW pump winterization fluid by Munro!

Rest easy knowing your pump is protected. Non-toxic, pump winterization fluid. Anti-freeze protection to -25 degrees F.

- Prevents damage due to freezing
- Helps protect your pump from corrosion
- Promotes longevity by keeping your pump rust free
- Protects equally well for plastic or cast iron pumps



### Did You Know?

We have a handy winterization guide on p. 256!

## Specifications

Approx. Weight lbs per Case	Concentrated Volume per Bottle	Prepared Volume per Bottle	Case Quantity	Model Number
10	24 oz.	64 oz.	6	FD25

To see just how EASY it is to winterize your pump using Freeze Defeat! Visit [munropump.com/FreezeDefeat](http://munropump.com/FreezeDefeat)



## Table of Contents

<b>Typical Systems</b> .....	190,191
<b>Worksheets</b>	
Centrifugal Pump Data .....	192
Water Feature Pump Data .....	193
Well Pump Data .....	194
Hose Selection .....	195
Pump Station RFQ .....	196
Simplicity Pump Station Parameters .....	197
Custom Controls .....	99, 198
<b>Charts &amp; Tables</b>	
Pump Controls Selection .....	199-204
Friction Loss .....	205-210
Wire Size .....	211,212
Capacities of Steel Pipe .....	212
Conversion Tables .....	213-215
Measuring Tools .....	216
<b>Glossary</b>	
Terms .....	217-228
Pump .....	229-232
Associations .....	232
<b>Installation Guides</b>	
M95 HDPE Coupling .....	233,234
M97 Transition Coupling .....	235,236
M7705 Flexible Coupling .....	237,238
Cut Groove Specs .....	239
Roll Groove Specs .....	240
<b>Troubleshooting Guides</b>	
Centrifugal Pumps & Controls .....	241-254
Float Switch 101 .....	255
Winterization .....	256
<b>Warranty</b> .....	257-258

## Ground Water Application

*Drawing from a shallow well, cistern, ditch or pond*

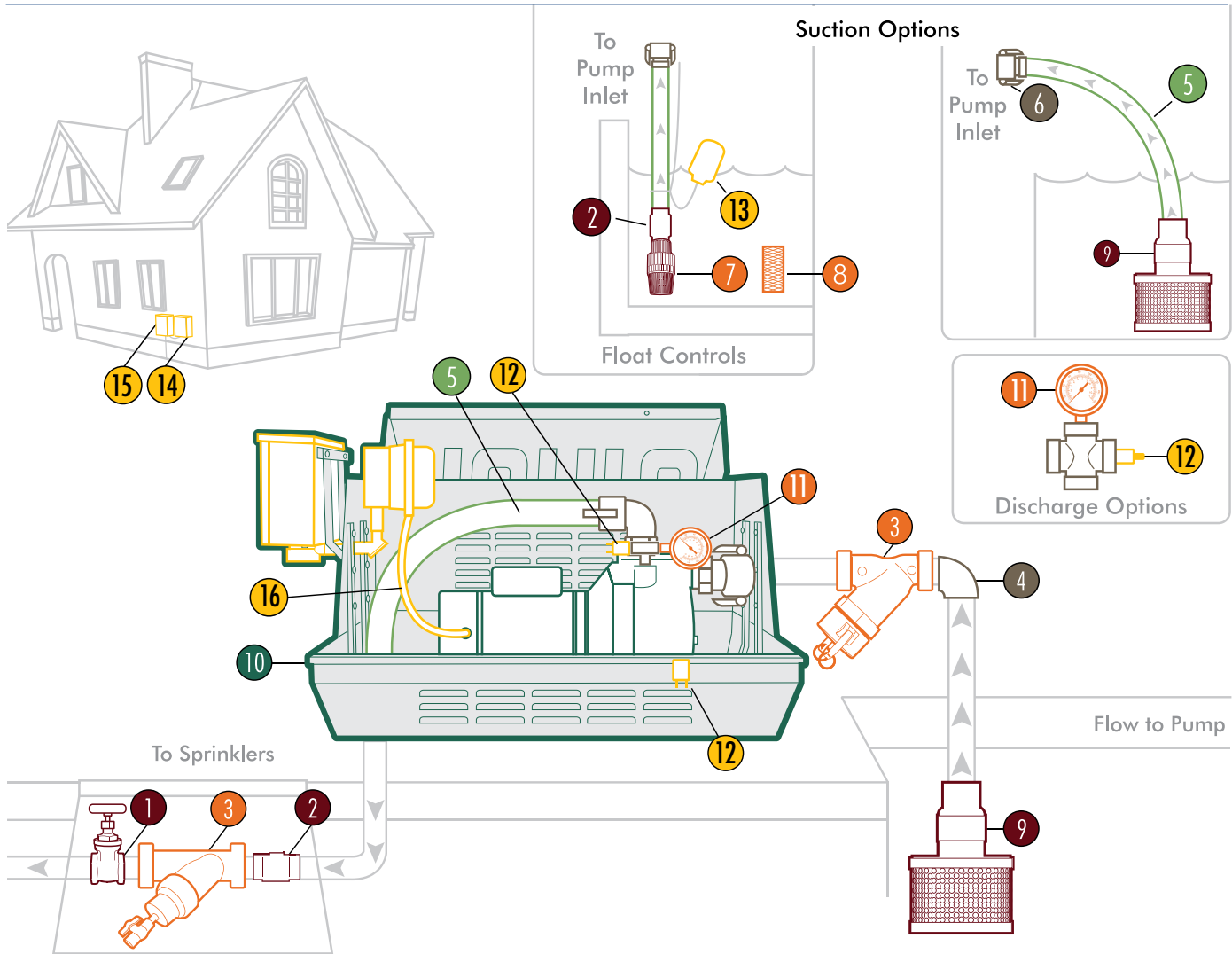

### Product Identification – Color coded to catalog section

#### Discharge & Suction Components

1	ISOLATION VALVE – Gate and ball valves allows pump isolation for ease of maintenance and winterization. (Pg. 174,175)
2	CHECK VALVE – On suction side, keeps pipe and pumps full of water, reducing wear at start of run-cycle. On discharge side, prevents system damage from water back-flowing or hammering. (Pg. 176,177)
3	Y-STRAINER – Keeps sprinklers from clogging by straining the water through a screen mesh. The “Y” design allows for easy cleaning of the screen mesh. (Pg. 181)
4	PIPE FITTINGS – Airtight line allows water to flow to and from pump. Multiple configurations are available. (Pg. 146-150)
5	HOSE – Provides a less expensive and more flexible alternative to steel or PVC pipework. (Pg. 121-130)
6	CAM COUPLING – Easily connect and disconnect while still being vacuum tight. (Pg. 134)

#### Suction Only Components

7	PVC FOOT VALVE – Keeps pipe and pump full of water, reducing unnecessary wear on pump at start of cycle. (Pg. 172)
8	INLET SCREEN – Screening allows water to flow without debris being pulled into the pump. Reduces amount of Y-strainer cleaning. (Pg. 183)
9	IRRIGATION FOOT VALVE – Large surface area allows water flow to sufficiently supply pump at full capacity while keeping line pull at start-up. (Pg. 171)

# Booster Application

System provides some initial pressure

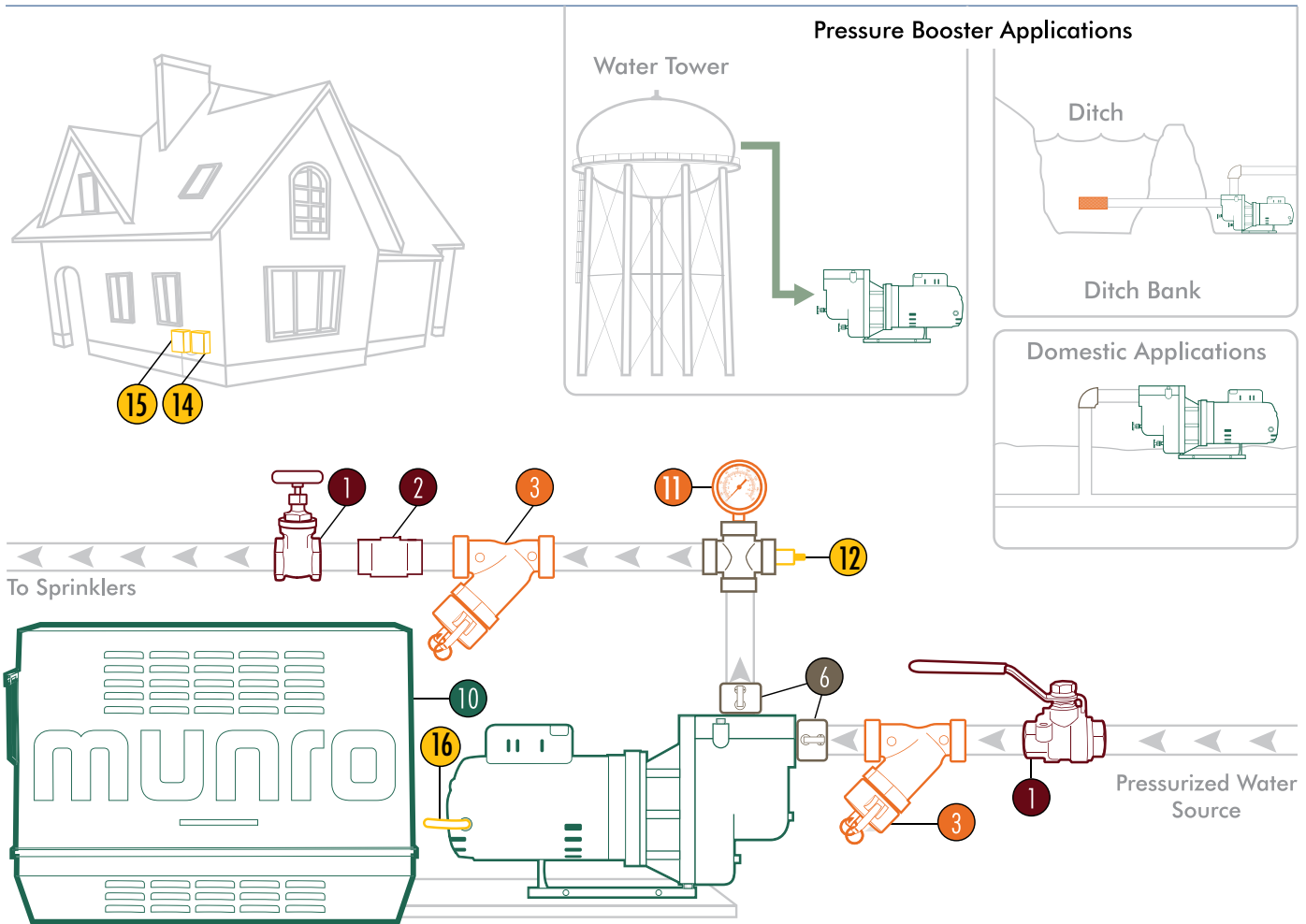

## Product Identification – Color coded to catalog section

### Pump & System Accessories

- 10** UNIVERSAL PRO ENCLOSURE – Protects pump from rain, dust and heat. Increases efficiency and adds to motor life. (Pg. 21)
- 11** PRESSURE GAUGE – This troubleshooting tool monitors system for pressure. (Pg. 185)
- 12** MONITORING SENSORS – Pressure and temperature sensors offers loss of prime and high temp protection when coupled with SmartBox controls. (Pg. 102)

### Electrical Components

- 13** FLOAT CONTROL – Provides hands-free pump operation by automatically signaling start and stop of pump cycle with rise and fall of float. (Pg. 100)
- 14** START SIGNAL – Command control to start and stop pump cycle – timer, lawn controller, manual switch. (See our Control Section on Pg. 76–106)
- 15** ELECTRICAL RELAY – Relay switch which allows electrical power to run between breaker and pump motor. (Pg. 102)
- 16** WIRING – For power supply and pump start. (Pg. 105,106)

RESOURCES

# Centrifugal Pump Data Worksheet

Complete worksheet then email to [technicalsupport@munropump.com](mailto:technicalsupport@munropump.com)

Name:	Company:	Phone:
Address:	City/State/Zip:	

<b>GPM</b>	<b>Pumping Requirements</b> To size a pump, first figure total gallonage needed. (For example: Irrigation system, household usage, etc.)		_____ GPM
	<b>Total Dynamic Head (TDH)</b>	<b>Suction Lift (not applicable in a booster application)</b> To determine suction lift, measure the vertical distance between the water level at the lowest point and the pump inlet. (Total measurement in feet)	_____ FEET
		<b>Elevation Change</b> To figure elevation, measure the vertical distance from the pump inlet to the highest point in the system. (Total measurement in feet)	_____ FEET
		<b>Friction Loss</b> To estimate friction loss, keep velocity feet per second at 5' +/- 1' to determine ideal pipe size. Refer to friction loss chart. (Total measurement in feet) *Refer to fitting manufacturer's friction loss info and add.	_____ FEET
		<b>PSI - Pounds Per Square Inch</b> IF Booster Application: (PSI required at the end of the largest zone _____ - incoming PSI _____) x 2.31 = _____ Feet IF Suction Lift Application: PSI required at the end of the largest zone _____ x 2.31 = _____ Feet.	_____ FEET
<b>Total Dynamic Head (TDH)</b> Total the sum of suction lift, elevation change, friction loss, PSI. This total equals TDH in feet.		_____ TDH	
<b>Misc.</b>	<b>Electrical</b> Voltage: <input type="checkbox"/> 115 Volt <input type="checkbox"/> 208 Volt <input type="checkbox"/> 230 Volt <input type="checkbox"/> 460 Volt Phase: <input type="checkbox"/> Single Phase <input type="checkbox"/> Three Phase	<b>Filtration</b> <input type="checkbox"/> Suction <input type="checkbox"/> Discharge	<b>Alternate Power Supply</b> <input type="checkbox"/> Engine Driven <input type="checkbox"/> Diesel <input type="checkbox"/> Gas
	<b>H2O Water Supply</b> <input type="checkbox"/> Suction from Pond, Lake or Ditch <input type="checkbox"/> Pump in Well <input type="checkbox"/> Flooded Suction <input type="checkbox"/> Harvested Water <input type="checkbox"/> Incoming Pressure _____ psi		

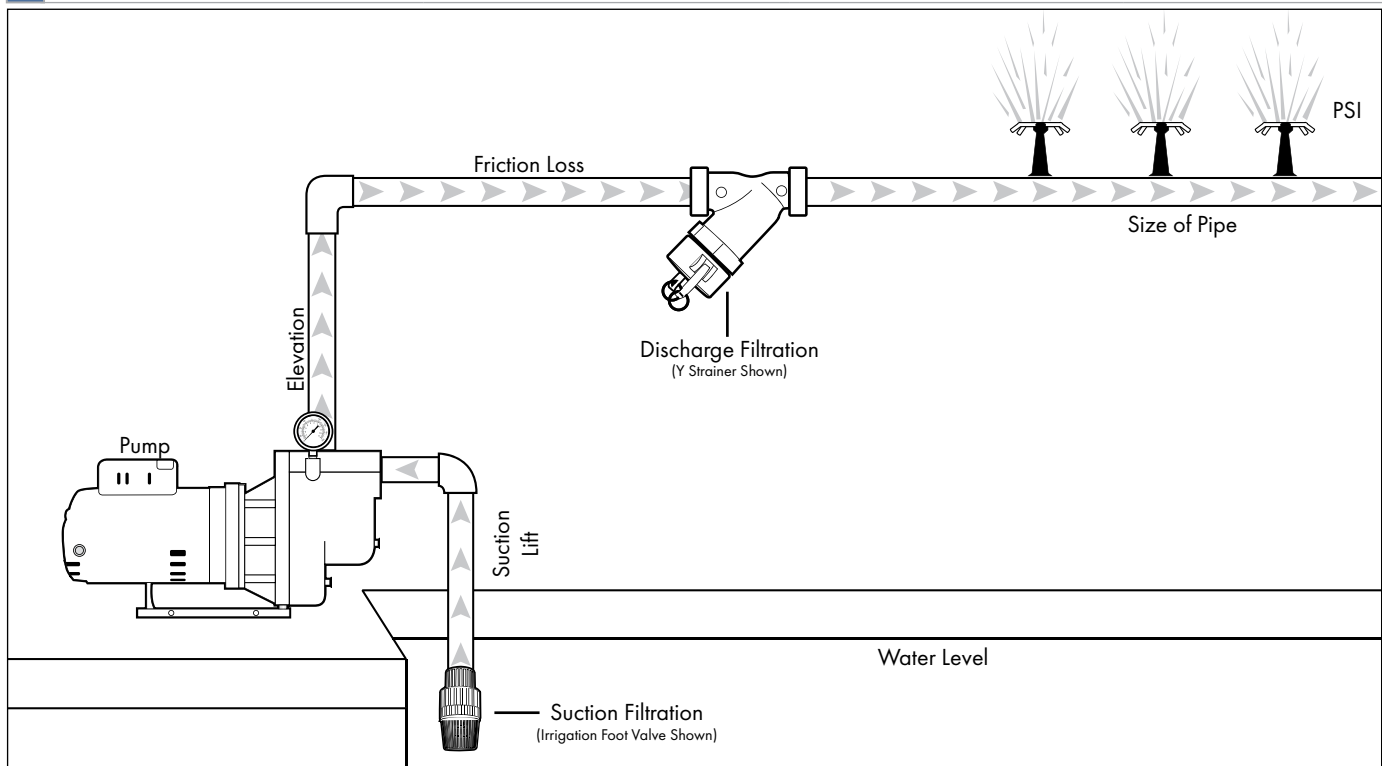

(Boost application not shown)

# Water Feature Pump Data Worksheet

This worksheet will help you calculate the flow rate and total dynamic head in feet (TDH), to find the performance requirements for your water feature pump.

Complete worksheet then email to [technicalsupport@munropump.com](mailto:technicalsupport@munropump.com).

Name:	Company:	Phone:
Address:		City/State/Zip:

<b>Flow Rate</b>	<p><b>Pumping Requirements</b> Determine flow rate required. Using the chart below, determine the discharge rate per foot based on the desired water flow depth. Multiply that number by the width of the weir. Desired flow depth _____ = Discharge rate per ft _____ Discharge rate per ft _____ x weir width (in feet) _____ = _____ GPM x 60 = _____ GPH</p>	<p>_____ GPM _____ GPH</p>
------------------	--	--------------------------------

<b>Weir Chart</b>	Water Flow Estimate Over A Weir					
	Flow Depth (inches)	Discharge Rate per foot of Weir Width	Flow Depth (inches)	Discharge Rate per foot of Weir Width	Flow Depth (inches)	Discharge Rate per foot of Weir Width
	1/2	13	3	187	6	528
	3/4	24	3 1/2	236	6 1/2	596
	1	36	4	287	7	605
	1 1/2	66	4 1/2	343	7 1/2	738
	2	102	5	402	8	814
2 1/2	142	5 1/2	463	8 1/2	890	

<b>Total Dynamic Head (TDH)</b>	<p><b>Elevation</b> a. Suction Lift When using a submersible pump, suction lift should be "0". When using a non-submersible pump, measure vertical distance from water level to pump inlet. (Total measurement in feet) b. Elevation Change To figure elevation, measure the vertical distance from the surface of water to the highest point of discharge. (Total measurement in feet)</p>	<p>(a) _____ FEET  (a) _____ FEET</p>
	+	
	<p><b>Friction Loss</b> Using GPM from above, consult friction loss chart (available on the Munro website or from your pipe manufacturer) to determine ideal pipe size (5' +/- 1'). Multiply loss per foot by (length of pipe/100).</p>	<p>_____ FEET</p>
	+	
	<p><b>PSI - Pounds Per Square Inch</b> Determine the pressure required to run both the fountain head and/or pressure filters (refer to the manufacturer's specifications). PSI x 2.31 = HEAD IN FEET</p>	<p>_____ FEET</p>
=		
<p><b>Total Dynamic Head (TDH)</b> Total the sum of elevation, friction loss and PSI. This total equals TDH in feet.</p>	<p>_____ TDH</p>	

<b>Misc.</b>	<p><b>Electrical</b> Voltage:    <input type="checkbox"/> 110 Volt    <input type="checkbox"/> 220 Volt    <input type="checkbox"/> 440 Volt Phase:      <input type="checkbox"/> Single Phase    <input type="checkbox"/> Three Phase</p>	<p><b>Filtration</b> Gravity:    <input type="checkbox"/> Waterfall    <input type="checkbox"/> Skimmer Pressure:   <input type="checkbox"/> Pressure      <input type="checkbox"/> Sand</p>	<p>Check manufacturer's specifications to determine PSI for filters.</p>
--------------	--	--	--

<b>Feature</b>	<input type="checkbox"/> Pond	<input type="checkbox"/> Fountain	<input type="checkbox"/> Pond-less
----------------	-------------------------------	-----------------------------------	------------------------------------

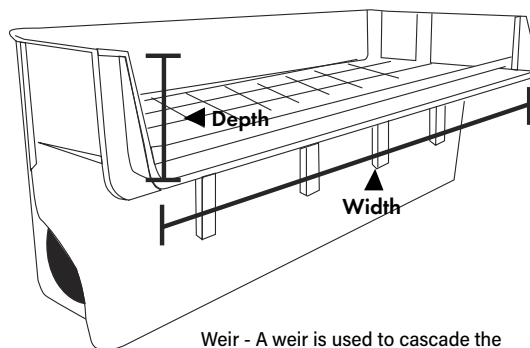
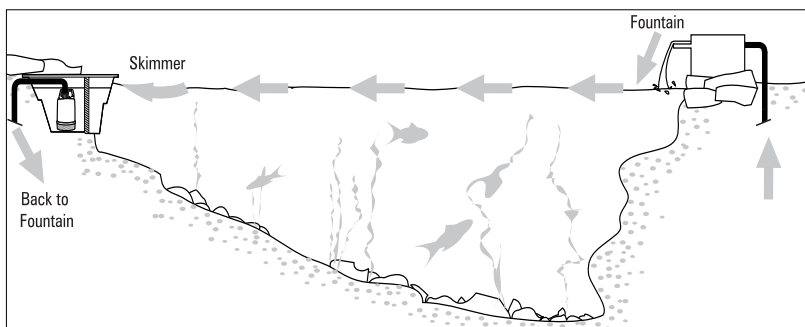

Weir - A weir is used to cascade the flow of water over a specific surface.

# Well Pump Data Worksheet

Complete worksheet then email to [mpi@munropump.com](mailto:mpi@munropump.com).

Name:	Company:	Phone:
Address:		City/State/Zip:
<b>Well depth:</b> Determined by the drillers report		
<b>Type of pump</b>	<b>Electrical</b>	
	Voltage:	<input type="checkbox"/> 110 Volt <input type="checkbox"/> 220 Volt <input type="checkbox"/> 440 Volt
	Phase:	<input type="checkbox"/> Single Phase <input type="checkbox"/> Three Phase
<input type="checkbox"/> Less than 25' – Shallow Well Jet Pump <input type="checkbox"/> 25' to 170' – Deep Well Jet Pump <input type="checkbox"/> 25' to 400' – Submersible Well Pump		

<b>Total Dynamic Head (TDH)</b>	<b>GPM</b>	<b>Pump Requirements:</b> Size of pump determined by counting the number of water using fixtures – showers, faucets, outdoor water spigots, dish-washing machine, refrigerators, clothes washers – times 3GPM.	_____GPM
	<b>Elevation</b>	a. Suction Lift To determine suction lift, measure the distance between the water level and the pump inlet. This will be 0 for submersible pumps. (Total measurement in feet)	(a) _____ FEET
		b. Elevation Change To figure elevation, measure the distance from the pump outlet to the highest point in the system. (Total measurement in feet)	(b) _____ FEET
	<b>Friction Loss*</b>	To estimate friction loss, first determine the size of pipe use. Refer to friction loss chart. Figure .5 foot of friction loss per valve or elbow (Total measurement in feet)	+ _____ FEET
	<b>PSI - Pounds Per Square Inch**</b>	Determine the pressure required to run all of the water using fixtures (refer to the manufacturer's specifications) PSI x 2.31 = HEAD IN FEET	+ _____ FEET
	<b>Total Dynamic Head (TDH)</b> Total the sum of elevation, friction loss and PSI. This total equals TDH in feet.	= _____ TDH	

\* Drop pipe size could be different from discharge size.

\*\* Regular house pressure = 40 - 60PSI

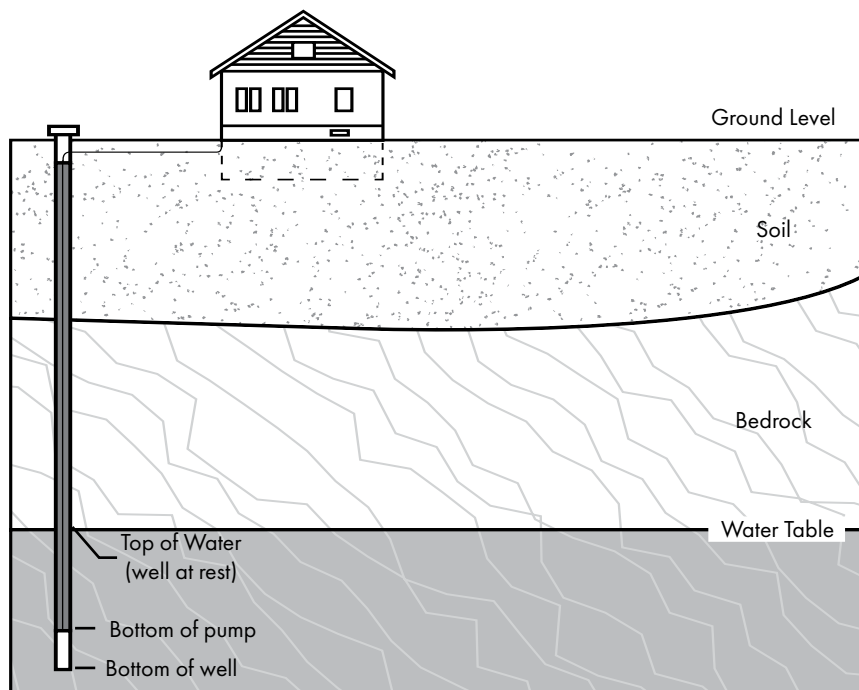

# Hose Specification and RFQ Form

Our hose capabilities and configurations are endless – with crimp capabilities to 10". If you need help selecting the right hose for the job, just call on the experts at Munro.

### What is the best type of hose for my application?

Important aspects for choosing the right type of hose can be summed up in an easy to remember acronym: **STAMPED**

<b>Size</b> – Inner diameter:	Length:
<b>Temperature</b> – Material conveyed: Min:      Max:	Environment: Min:      Max:
<b>Application</b> – How will the hose be used?	
Suction or Discharge? <input type="checkbox"/> Suction <input type="checkbox"/> Discharge	Will it be drug? <input type="checkbox"/> Yes <input type="checkbox"/> No
What is the environment the hose will be in?	
<b>Media</b> – What will be going through the hose? <input type="checkbox"/> Dirty Water <input type="checkbox"/> Clean Water <input type="checkbox"/> Chemicals <input type="checkbox"/> Fuels <input type="checkbox"/> Other:	
<b>Pressure</b> – To how much pressure will the assembly be exposed?	Max PSI:
<b>Ends</b> – What type?	Orientation?
What attachment methods are needed?	

### Delivery Information

Quantity Required:	Date Required:	Special Requirements?
Package Type:		
Requested Delivery Date:	Ship Via:	
Testing Required: <input type="checkbox"/> Yes <input type="checkbox"/> No	Type:	
Certification Required: <input type="checkbox"/> Yes <input type="checkbox"/> No	Type:	

### Common hose types:

Suction (can be used for discharge if shape is required)

- PVC Clear – a basic, economical option
- PVC OD critical schedule 40 sized (spa hose) – for applications where glued joints are necessary
- PVC Industrial Strength – fabric reinforced hose with external drag helix
- Rubber – smooth cover, good for water applications
- Oilfield Suction – offers durable external cover and enhanced bend radius and is acceptable in applications where hydrocarbons may be present

Discharge Layflat Hose – easy to bring to a job site and roll out for immediate use

- PVC Layflat Blue – for lower pressure applications – Max. 40–80 PSI
- PVC Layflat Red – for medium pressures – Max. 100–150 PSI
- Mill Hose – includes a cloth cover for added durability – Max. 150 PSI
- Rubber Discharge Hose – industrial strength discharge hose
- General Purpose Air & Water Hose – when garden hose will not cut it... this heavy duty hose is perfect for spray down applications or air compressor service

### Common hose end fitting options



King Nipples  
p. 139

C - Cam and Groove  
Coupling  
p. 134

E - Cam and Groove  
Coupling  
p. 135

Groove King Nipple  
p. 139

Crows Foot  
p. 141

Ball & Socket  
p. 140

Pin Lug  
p. 141

RESOURCES

# Pump Station Specification and RFQ Form

PROJECT NAME \_\_\_\_\_

LOCATION \_\_\_\_\_

CLIENT (COMPANY) \_\_\_\_\_

Contact Name \_\_\_\_\_ Email \_\_\_\_\_

Phone \_\_\_\_\_ Fax \_\_\_\_\_

### PROJECT TIME LINE

\*Stations typically ship 6 to 8 weeks after the purchase order is received, and the signed submittal is returned.

Request quote by \_\_\_\_\_ Project bid date \_\_\_\_\_

Expected project start date \_\_\_\_\_ Expected completion date \_\_\_\_\_

### SYSTEM CRITERIA

\*Must select suction lift or pressure boost

**Pressure Boost**

Available dynamic inlet pressure at the pump for rated flow (less all pressure losses prior to the pump i.e.; backflow, meter, elevation, friction losses, etc.) \_\_\_\_\_

Max. flow rate \_\_\_\_\_ Min. flow rate \_\_\_\_\_

Total operating pressure \_\_\_\_\_

**Suction lift**

Height of suction lift \_\_\_\_\_

Max. flow rate \_\_\_\_\_ Min. flow rate \_\_\_\_\_

Total operating pressure \_\_\_\_\_

### Power source

230V/1PH  208V/3PH  230V/3PH  460V/3PH

Signature required for power verification \_\_\_\_\_

### Station start

Clock start (from external 24v signal)

Remote pressure start (from change in system pressure)

### Filtration requirements

Suction:  Yes  No Discharge:  Yes  No Discharge filter micron \_\_\_\_\_

### Enclosure

None  Powdercoated marine grade aluminum (standard)

Powdercoated stainless steel  Other \_\_\_\_\_

### ADDITIONAL OPTIONS

Flow meter

Master valve

Z Pipe (provide length)

bypass (boost only)

Touchscreen

Remote monitoring

Heater

Insulation

Strainers or foot valves

100% Hunter project (5 yr warranty)

Baseline integration (5 yr warranty)

# Simplicity Specification and RFQ Form

**PROJECT NAME** \_\_\_\_\_

**LOCATION** \_\_\_\_\_

**CUSTOMER (DISTRIBUTOR)** \_\_\_\_\_

Contact Name \_\_\_\_\_ Email \_\_\_\_\_

Phone \_\_\_\_\_ Fax \_\_\_\_\_

**PROJECT TIME LINE**

Simplicity pump stations typically ship 1 to 3 weeks after the purchase order is received.

Quote date \_\_\_\_\_ Project bid date \_\_\_\_\_

Expected project start date \_\_\_\_\_ Expected start-up date \_\_\_\_\_

**SYSTEM CRITERIA**

Must select suction lift or pressure boost

**Suction lift (self-priming centrifugal)** (Note: Suction lift model in 5hp only)

Suction lift height > 12' \_\_\_\_\_

Total flow required (gpm) \_\_\_\_\_

Total pressure required (psi) \_\_\_\_\_

**Pressure boost (straight centrifugal with bypass)**

Dynamic inlet pressure at the pump \_\_\_\_\_

*less all pressure losses prior to the pump i.e.; backflow, meter, elevation, friction losses, etc.*

Total flow required (gpm) \_\_\_\_\_

Total boost required (psi) \_\_\_\_\_

Total operating pressure required (psi) \_\_\_\_\_

**Power Source**

230V/1PH  208V/3PH  230V/3PH  460V/3PH

Signature required for power verification \_\_\_\_\_

**Station Start**

Clock start (from external 24v signal)

Remote pressure start (from change in system pressure)

**Z Pipe**

Yes  No

**Commissioning/Start-up**

Phone start with Munro support (standard)

In-person start with Authorized Service Provider (+\$1,200)

Simplicity model that meets these requirements: \_\_\_\_\_

Notes or other requirements: \_\_\_\_\_

**CUSTOMER CONFIRMATION**

These parameters are accurate and I understand and agree to the proposal clarifications. I understand that Munro strongly recommends that the distributor confirms specifications and site conditions with contractor and/or end user.

\_\_\_\_\_  
Distributor Contact Signature (required) Company Date

\_\_\_\_\_  
User Contact Signature (not required) Company Date

RESOURCES



## Fundamentals of pump controls

In your home lighting, all wires are attached to breakers in your breaker box. You don't have to run out and engage a breaker each time you want to turn on a light... you simply flip a switch. One side of the switch is continually attached and 'hot' from the wire from your breaker box, and the flipping of the switch allows the power to reach your light fixture. The person, by flipping the switch, is signaling when the light should be on.

Pump controls function similarly. They are like a light switch reacting to a signal for your pump to turn on and provide water to your irrigation system.

## Pump Start Relays (StartBox)

A pump start relay requires an independent start/stop signal to determine when power should be sent to the pump. Pump start relays, like your light switch, only function flipped on or off; and require an external force to flip them on or off.

Irrigation systems commonly use lawn controllers to signal the pump start relay to allow power to reach, and turn on, the pump. When the lawn controller stops sending the 'on' signal, the pump start relay will automatically switch 'off' and power to the pump is discontinued.

While not every irrigation system uses a lawn controller, an outside force must act on a pump start relay to start and stop the power flow to the pump. Pump start relays continue the flow of power based on the signal from that outside force.

## Pump Start Relays + Protection (SmartBox)

SmartBoxes provide the same start/stop function that the StartBox does. Additionally, though, a SmartBox monitors the pump to protect it from running dry or overheating due to loss of prime and/or dead-heading. The way that the SmartBox protects the pump is by monitoring the pump system for abnormal running conditions through the use of sensors.

A SmartBox will override the 'on' signal of the lawn controller and discontinue power to your pump if one of the sensors indicate that a problem, like loss of prime or dead heading, exists. Once the lawn controller has stopped sending the 'on' signal, the SmartBox clears the protective shut-down and will send power to the pump again at the next 'on' signal.

## Which pump control box do I need?

Follow the steps below to determine the appropriate pump control for your application, using the pump control selection chart. If you do not see an option that fits your application, you may need a custom control box.

- 1) Determine the primary function of your base box. The base box type is indicated in the chart title.

I WANT TO...	YOU NEED A...
Simple pump on/off	StartBox Control
Pump on/off with protection to avoid pump meltdowns	SmartBox Control
Utilize harvested water from a tank when it is available	BrainBox Water Harvesting Control
Protect a water feature pump from cycling	DamBox Water Feature Control
Maintain a Liquid, or tank, level	Liquid Level Control
Use multiple pumps or controllers on a system	Specialty Controls
Limit run time and frequency of a pump or lighting system	Specialty Controls
Start and stop a pump on demand	Specialty Controls

- 2) Use the following guidelines to determine the specific features of your box, always following the sectional titles.
  - a. Control Voltage – Is the Start/Stop or Signal Voltage being sent to your system. Lawn Controllers send a 24v signal, while floats, sensors, and switches may match the pump voltage.
  - b. Product Description – Provides a list of features included on the listed control box
  - c. Protections – There are two different types of pump protection offered.
    - i. Low Pressure System cut-off protects your pump from running dry and damaging the seal.
    - ii. High Temperature System shut-down protects your pipework from over-heating if a valve doesn't open.
  - d. Low Incoming Amp Compatible – Some lawn controllers send less than a .35 amp signal. These controllers require special accommodation based on the line voltage running to the pump.
  - e. Low Voltage/Safe Out – Any voltage leaving the control box, to floats or other external components, will be reduced to a safe 24v level. This is recommended whenever an external component, like a float switch, is used.
  - f. Hand Off Auto (HOA) – Provides an override to shut off (O) or start (H) power to the pump, even if the lawn controller is not cycling. Normal run cycle (A) enables full control function.
  - g. Motor Information – Shows the amperage range and maximum hp allowed by each box. Consult the motor nameplate to verify this information.
- 3) Items listed as optional (O) can be ordered by contacting Munro at 800-942-4270.
- 4) Items listed as not available (-) are not applicable to this box configuration.
- 5) NEC requires all motors to be thermally protected either by motor design or control panel. Consult motor nameplate. If the motor is not thermally protected, please select a control box with thermal protection to comply with NEC.

Note: The Controls Selection Charts are intended for reference in finding a control based on basic needs and common options. Many of these part numbers are never-been-built items listed for reference only. Some of these controls may require additional processing time.

# StartBox – Pump Start Relays

Control Voltage	Product Description	Protections		Low Incoming Amp Compatible		Low Voltage - Safe 24V Signal*	Thermal Protection	HOA	Motor Info		Box Size	Page #	Part Number		
		Low Pressure Cut-off	High Temp Shut-down	110V	220V				Motor Shut-down (amp range)	Max HP			Blue Box	SS Box	
24v Control	StartBox - 24v	See SmartBox options		N	N	Y	N	O	120v - 24FLA 240v - 28FLA	120v - 2hp 240v - 5hp	6x6x4	77	MPSR24	MPSR24S	
	LOW INCOMING AMP COMPATIBLE														
	StartBox - 24v, Low Incoming Amp, Safe Out 110 line	See SmartBox options		Y	N	Y	N	O	120v - 24FLA 240v - 28FLA	120v - 2hp 240v - 5hp	8X8X4	78	MPSR242W11	MPSR242W11S	
	StartBox - 24v, Low Incoming Amp, Safe Out 220 line			N	Y	Y	N	O			8X8X4	78	MPSR242W22	MPSR242W22S	
	THERMALLY PROTECTED														
	StartBox - 24v, 3hp w/ Therm Pro, HOA	See SmartBox options		O	O	Y	Y	Y	14.7 - 15.8	3 hp	12x12x6	79	MPSR24V3	MPSR24V3S	
	StartBox - 24v, 5hp w/ Therm Pro, HOA			O	O	Y	Y	Y	24.1 - 25.9	5 hp	12x12x6	79	MPSR24V5	MPSR24V5S	
	StartBox - 24v, 7.5hp w/ Therm Pro, HOA			O	O	Y	Y	Y	34 - 40	7.5 hp	12x12x6	79	MPSR24V75	MPSR24V75S	
StartBox - 24v, 10hp w/ Therm Pro, HOA	O			O	Y	Y	Y	40 - 50	10 hp	12x12x6	79	MPSR24V10	MPSR24V10S		
110v Control	StartBox - 110v, Safe Out			O		Y	N	O	56 FLA	5	12x12x6	77	MPSR110A	MPSR110AS	
	StartBox - 110v - w/ Therm Pro			O		--	N	O	34 FLA	3	8X8X4	99	MPSR110V3	MPSR110V3S	
	StartBox - 110v, (3 - 10 hp) w/Therm Pro, HOA			O		O	N	Y	Varies by hp	10	12x12x6	99	Call for part #	Call for part #	
220v Control	LOW VOLTAGE (24V) SAFE OUT														
	StartBox - 220v, Safe Out, HOA	See SmartBox section		--		Y	N	Y	28 FLA	5	12X12X6	77	MPSR220A	MPSR220AS	
	THERMAL PROTECTION PROVIDED														
	StartBox - 220v, 3hp, w/ Therm Pro	See SmartBox section		--	Y	Y	N	14.7 - 15.8	3	12X12X6	79	MPSR220V3	MPSR220V3AS		
	StartBox - 220v, 3hp, w/ Therm Pro, HOA				Y	Y	Y	14.7 - 15.8	3	12X12X6	99	MPSR220V3H	MPSR220V3HAS		
	StartBox - 220v, 5hp, w/ Therm Pro				Y	Y	N	24.1 - 25.9	5	12X12X6	79	MPSR220V5	MPSR220V5AS		
	StartBox - 220v, 5hp, w/ Therm Pro, HOA				Y	Y	Y	24.1 - 25.9	5	12X12X6	99	MPSR220V5H	MPSR220V5HAS		
	StartBox - 220v, 7.5hp w/ThermPro				Y	Y	N	34 - 40	7.5	12X12X6	79	MPSR220V75	MPSR220V75AS		
	StartBox - 220v, 7.5hp w/ThermPro, HOA				Y	Y	Y	34 - 40	7.5	12X12X6	99	MPSR220V75H	MPSR220V75HAS		
	StartBox - 220v, 10hp w/ Therm Pro				Y	Y	N	40 - 50	10	12X12X6	79	MPSR220V10	MPSR220V10AS		
StartBox - 220v, 10hp w/ Therm Pro, HOA	Y				Y	Y	40 - 50	10	12x12x6	99	MPSR220V10H	MPSR220V10HAS			

\*Recommended whenever an external component, like a float switch, is used.  
 Consult motor nameplate to verify specific motor data  
 NEC requires all motors to be thermally protected either by motor design or control panel – consult motor nameplate

Y = Yes, Included  
 O = Option Available – see page 90 for custom box or contact Munro  
 -- = Not Available  
 N = NO, Not Included

## SmartBox – Pump Start Relay + Protection

Control Voltage	Product Description	Protections		Low Incoming Amp Compatible		Low Voltage - Safe 24V Signal*	Thermal Protection	HOA	Motor Info		Box Size	Page #	Part Number		
		Low Pressure Cut-off	High Temp Shut-down	110V	220V				Motor Shut-down (amp range)	Max HP			Blue Box	SS Box	
24v Control	SmartBox - 24v	Y	N	N	N	Y	N	O	120v - 24FLA 240v - 28FLA	120v - 2hp 240v - 5hp	8X8X4	80	MPLC24	MPLC24S	
	SmartBox - 24v, Temp Sensor	Y	Y	N	N	Y	N	O			8X8X4	80	MPLC24T	MPLC24TS	
	LOW INCOMING AMP COMPATIBLE														
	SmartBox - 24v, Low Incoming Amp, Low Pressure and High Temp Sensors, 110 line, HOA	Y	Y	Y	N	Y	N	Y	120v - 24FLA 240v - 28FLA	120v - 2hp 240v - 5hp	12x12x6	81	MPLC242W11	MPLC242W11S	
	SmartBox - 24v, Low Incoming Amp, Low Pressure and High Temp Sensors, 220 line, HOA	Y	Y	N	Y	Y	N	Y			12x12x6	81	MPLC242W22	MPLC242W22S	
	THERMALLY PROTECTION PROVIDED														
	SmartBox - 24v, 3hp w/ Therm Pro, Low Pressure and High Temp Sensors, HOA	Y	Y	O	O	Y	Y	Y	14.7 - 15.8	3 hp	12x12x6	82	MPLC243T	MPLC243TS	
	SmartBox - 24v, 5hp w/ Therm Pro, Low Pressure and High Temp Sensors, HOA	Y	Y	O	O	Y	Y	Y	24.1 - 25.9	5 hp	12x12x6	82	MPLC245T	MPLC245TS	
	SmartBox - 24v, 7.5hp w/ Therm Pro, Low Pressure and High Temp Sensors, HOA	Y	Y	O	O	Y	Y	Y	34 - 40	7.5 hp	12x12x6	82	MPLC2475T	MPLC2475TS	
	SmartBox - 24v, 10hp w/ Therm Pro, Low Pressure & High Temp Sensor, HOA	Y	Y	O	O	Y	Y	Y	40 - 50	10 hp	12x12x6	82	MPLC2410T	MPLC2410TS	
110v Control	SmartBox - 110v	Y	O	O	See 220V Controls	Y	N	O	24 FLA	2 hp	6x6x4	80	MPLC110T	MPLC110TS	
	SmartBox - 110v, Safe Out	Y	O	--		Y	N	O	24 FLA	2 hp	12x12x6	99	Call for part #	Call for part #	
	SmartBox - 110v, (3 - 10 hp) w/Thermal Pro, HOA	Y	O	O		O	Y	O	Varies by hp	10 hp	12x12x6	99	Call for part #	Call for part #	
220v Control	SmartBox - 220v, Safe Out, Low Pressure and High Temp Sensors	Y	Y	--		Y	N	O	28 FLA	5	12X12X6	80	MPLC220T	MPLC220TS	
	THERMAL PROTECTION PROVIDED														
	SmartBox - 220v 3hp w/ ThermPro, Low Pressure and High Temp Sensors	Y	Y			Y	Y	N	14.7 - 15.8	3	12X12X6	82	MPLC2203AT	MPLC2203ATS	
	SmartBox - 220v 3hp w/ ThermPro, Low Pressure and High Temp Sensors, HOA	Y	Y			Y	Y	Y	14.7 - 15.8	3	12X12X6	99	MPLC2203HATH	MPLC2203ATHS	
	SmartBox - 220v 5hp w/ ThermPro, Low Pressure and High Temp Sensors	Y	Y			Y	Y	N	24.1 - 25.9	5	12X12X6	82	MPLC2205AT	MPLC2205ATS	
	SmartBox - 220v 5hp w/ ThermPro, Low Pressure and High Temp Sensors, HOA	Y	Y			Y	Y	Y	24.1 - 25.9	5	12X12X6	99	MPLC2205ATH	MPLC2205ATHS	
	SmartBox - 220v 7.5hp w/ ThermPro, Low Pressure and High Temp Sensors	Y	Y			Y	Y	N	34 - 40	7.5	12X12X6	82	MPLC22075AT	MPLC22075ATS	
	SmartBox - 220v 7.5hp w/ ThermPro, Low Pressure and High Temp Sensors, HOA	Y	Y			Y	Y	Y	34 - 40	7.5	12X12X6	99	MPLC22075ATH	MPLC22075ATHS	
	SmartBox - 220v 10hp w/ ThermPro, Low Pressure and High Temp Sensors	Y	Y			Y	Y	N	40 - 50	10	12X12X6	82	MPLC22010AT	MPLC22010ATS	
SmartBox - 220v 10hp w/ ThermPro, Low Pressure and High Temp Sensors, HOA	Y	Y			Y	Y	Y	40 - 50	10	12X12X6	99	MPLC22010ATH	MPLC22010ATHS		

\* Recommended whenever an external component, like a float switch, is used.  
Consult motor nameplate to verify specific motor data  
NEC requires all motors to be thermally protected either by motor design or control panel – consult motor nameplate

Y = Yes, Included  
O = Option Available – see page 90 for custom box or contact Munro  
-- = Not Available  
N = NO, Not Included

## BrainBox – Water Harvest Controls

Control Voltage	Product Description	Protections		Low Incoming Amp Compatible		Low Voltage - Safe 24V Signal*	Thermal Protection	HOA	Motor Info		No. of Floats	Box Size	Special Features	Page #	Part Number		
		Low Pressure Cut-off	High Temp Shut-down	110V	220V				Motor Shut-down (amp range)	Max HP					Blue Box	SS Box	
24v	PARTIAL TANK UTILIZATION																
	BrainBox - 24v, Low Incoming Amp, Low Pressure and High Temp Sensors, 2 Floats, 110v Line	Y	Y	Y	--	N/A	Y	O	120v - 24 FLA	2	2	12x12x6	Uses any avail. water in a tank	84	MBRB242W11	MBRB242W11S	
	BrainBox - 24v, Low Incoming Amp, Low Pressure and High Temp Sensors, 2 Floats, 220v Line	Y	Y	--	Y	N/A	Y	O	240v - 28 FLA	5	2	12x12x6	Auto-fill w/ float max when controller off	84	MBRB242W22	MBRB242W22S	
	FULL TANK UTILIZATION																
	BrainBox Max - 24v, Low Incoming Amp, Safe Out, Indicator Lights, 2 Float, 110v line	Y	Y	Y	-	N/A	Y	O	120v - 24 FLA	2	2	12x12x6	Uses tank water only when full	84	MBRBMAX242WA11	MBRBMAX242WA11S	
	BrainBox Max - 24v, Low Incoming Amp, Safe Out, Indicator Lights, 2 Float, 220v line	Y	Y	-	Y	N/A	Y	O	240v - 28 FLA	5	2	12x12x6		84	MBRBMAX242WA22	MBRBMAX242WA22S	
24v	BrainBox - 24v, Low Pressure and High Temp Sensors, 1 Float	Y	Y	N	N	N/A	N	N	120v - 24 FLA	2	1		Uses any available water in a tank	84	MBRB241	MBRB241S	
	BrainBox - 24v, Low Pressure and High Temp Sensors, 2 Float	Y	Y	N	N	N/A	N	N	240v - 28 FLA	2	2			84	MBRB242	MBRB242S	

## DamBox – Water Feature Protection

Control Voltage	Product Description	Protections		Low Incoming Amp Compatible		Low Voltage - Safe 24V Signal*	Thermal Protection	HOA	Motor Info		Box Size	Special Features	Page #	Part Number	
		Low Pressure Cut-off	High Temp Shut-down	110V	220V				Motor Shut-down (amp range)	Max HP				Blue Box	SS Box
110v	DamBox - 110v	O	O	O	--	Y	N	O	24 FLA	2	8x8x6	Prevents pump cycling due to clogged filter	91	MPDB110A	MPDB110AS
220V	DamBox - 220v	O	O	--	O	Y	N	O	24 FLA	5	8x8x6		91	MPDB220A	MPDB220AS

\*Recommended whenever an external component, like a float switch, is used.  
 Consult motor nameplate to verify specific motor data  
 NEC requires all motors to be thermally protected either by motor design or control panel – consult motor nameplate

Y = Yes, Included  
 O = Option Available – see page 90 for custom box or contact Munro  
 -- = Not Available  
 N = NO, Not Included

## Liquid Level Controls

Control Voltage	Product Description	Protections		Low Voltage - Safe 24V Signal*	HOA	Thermal Protection	Motor Info			Box Size	Page #	Part Number	
		Low Pressure Cut-off	High Temp Shut-down				Thermal Overload Protection (amp range)	Largest Motor	Float Switch Included			Blue Box	SS Box
110v Control	StartBox - 110v, Safe Out, Pump Down Float, HOA	O	O	Y	O		24 FLA	2	1	12X12X6	90	MPSR110AD	MPSR110ADS
	StartBox - 110v, Safe Out, Pump Up Float, HOA	O	O	Y	O			2	1	12X12X6	90	MPSR110AU	MPSR110AUS
220v Control	StartBox - 220v, Safe Out, Pump Down Float, HOA	O	O	Y	O		28 FLA	5	1	12X12X6	90	MPSR220AD	MPSR220ADS
	StartBox - 220v, Safe Out, Pump Up Float, HOA	O	O	Y	O			5	1	12X12X6	90	MPSR220AU	MPSR220AUS
	StartBox - 220v, 3 hp, Safe Out, Pump Down Float			Y	O		14.7 - 15.8	3	1	12X12X6	90	MPSR220A3D	MPSR220A3DS
	StartBox - 220v, 3 hp, Safe Out, Pump Up Float			Y	O			3	1	12X12X6	90	MPSR220A3U	MPSR220A3US
	StartBox - 220v, 5 hp, Safe Out, Pump Down Float			Y	O		24.1 - 25.9	5	1	12X12X6	90	MPSR220A5D	MPSR220A5DS
	StartBox - 220v, 5 hp, Safe Out, Pump Up Float			Y	O			5	1	12X12X6	90	MPSR220A5U	MPSR220A5US
	StartBox - 220v, 7.5 hp, Safe Out, Pump Down Float			Y	O		34 - 40	7.5	1	12X12X6	90	MPSR220A75D	MPSR220A75DS
	StartBox - 220v, 7.5 hp, Safe Out, Pump Up Float			Y	O			7.5	1	12X12X6	90	MPSR220A75U	MPSR220A75US
	StartBox - 220v, 10 hp, Safe Out, Pump Down Float			Y	O		40 - 50	10	1	12X12X6	90	MPSR220A10D	MPSR220A10DS
	StartBox - 220v, 10 hp, Safe Out, Pump Up Float			Y	O			10	1	12x12x6	90	MPSR220A10U	MPSR220A10US

## Specialty Boxes

Control Voltage	Product Description	Protections		Low Incoming Amp Compatible (W)		Low Voltage - Safe 24V Signal*	Thermal Protection	HOA	Motor Info		Box Size	Special Features	Info on Page #	Part Number	
		Low Pressure Cut-off	High Temp Shut-down	110V	220V				High Thermal Motor Shut-down	Max HP				Blue Box	SS Box
MULTIPLE PUMPS OR CONTROLLERS															
24	Startbox - 24v to work with 2 controllers and 1 pump	O	O	O	O	--	O	O	--	3	12x12x6	Multiple Controllers	86	MPSR 242W2-3XC22	MPSR 242W2-3XC22S
220	StartBox - 220v to run 2 pumps with 1 lawn controller	O	O	O	O	O	O	O	O	3	12x12x6	Multiple Pumps	87	MPSR 242W2XP22	MPSR 242W2XP22S
TIMEBOX															
110	TimeBox - 110v, Timed/Adjustable on/off	--	--	--	--	Y				2	12x12x6	1-24v Solenoid Valve Start Signal	88	MPSR110MYSAV	MPSR110MYSAVS
110	TimeBox - 110v, Timed/Adjustable on/off	--	--	--	--	Y				2	12x12x6	2-24v Solenoid Valve Start Signal	88	MPSR1102MYSAV	MPSR1102MYSAVS
PRESSURE AND FLOW START/STOP															
220	StartBox - 110v, Pressure and Flow start	--	Y	--	--	Y				2	12x12x6	Self-Monitoring System - no tank required	89	MPSR110AYF	MPSR110AYFS
220	StartBox - 220v, Pressure and Flow start	--	Y	--	--	Y				2	12x12x6	Self-Monitoring System - no tank required	89	MPSR220AYF	MPSR220AYFS

\* Recommended whenever an external component, like a float switch, is used.

Consult motor nameplate to verify specific motor data

NEC requires all motors to be thermally protected either by motor design or control panel – consult motor nameplate

Y = Yes, Included  
 O = Option Available – see page 90 for custom box or contact Munro  
 -- = Not Available  
 N = NO, Not Included

## Friction Loss – Schedule 40 Pipe

For Water at 60° F per 100 Feet of Pipe

Pipe Size U.S. Gallons Per Min.	3/4" (1.05" OD) (.80" ID)			1" (1.315" OD) (1.03" ID)			1-1/4" (1.66" OD) (1.36" ID)			1-1/2" (1.9" OD) (1.59" ID)			2" (2.375" OD) (2.05" ID)			2-1/2" (2.875" OD) (2.45" ID)		
	VEL Ft. Per Sec.	Head Loss Feet Steel Plastic		VEL Ft. Per Sec.	Head Loss Feet Steel Plastic		VEL Ft. Per Sec.	Head Loss Feet Steel Plastic		VEL Ft. Per Sec.	Head Loss Feet Steel Plastic		VEL Ft. Per Sec.	Head Loss Feet Steel Plastic		VEL Ft. Per Sec.	Head Loss Feet Steel Plastic	
2	1.20	1.93	1.04	0.80	0.60	0.32												
4	2.40	6.94	3.74	1.50	2.14	1.16	0.86	0.56	0.30	0.63	0.20	0.11						
6	3.60	14.70	7.95	2.20	4.54	2.45	1.29	0.85	0.46	0.95	0.56	0.31	0.57	0.17	0.09			
8	<b>4.80</b>	25.00	13.50	3.00	7.78	4.20	1.72	1.20	0.65	1.26	0.96	0.52	0.77	0.28	0.15	0.54	0.12	0.06
10	<b>6.00</b>	37.80	20.40	3.70	11.70	6.32	2.15	2.04	1.10	1.58	1.45	0.78	0.96	0.43	0.23	0.67	0.18	0.10
12	7.20	53.00	28.60	<b>4.50</b>	16.40	8.86	2.57	3.08	1.66	1.89	2.04	1.10	1.15	0.60	0.33	0.80	0.25	0.14
15	9.00	80.00	43.30	<b>5.60</b>	24.80	13.39	3.17	6.54	3.53	2.37	3.09	1.67	1.53	1.03	0.56	0.98	0.36	0.19
18	10.80	112.00	60.50	6.70	34.70	18.74	3.86	6.72	3.63	2.84	4.31	2.33	1.72	1.28	0.69	1.21	0.54	0.29
20	12.00	136.00	73.50	7.40	42.10	22.73	<b>4.29</b>	9.13	4.93	3.15	5.24	2.83	1.91	1.55	0.84	1.34	0.65	0.35
25				9.30	63.60	34.34	<b>5.36</b>	11.10	5.99	3.80	7.30	3.94	2.55	2.73	1.47	1.63	0.92	0.50
30				11.10	89.20	48.17	6.43	16.80	9.07	<b>4.72</b>	11.00	5.94	2.87	3.29	1.78	2.01	1.39	0.75
35				13.00	119.00	64.26	7.51	23.50	12.69	<b>5.51</b>	14.70	7.94	3.35	4.37	2.36	2.35	1.84	0.99
40				14.90	152.00	82.08	8.58	31.20	16.85	6.30	18.30	9.88	3.82	5.60	3.02	2.68	2.36	1.27
45				16.70	189.00	102.06	9.64	50.20	27.11	7.03	23.20	12.53	<b>4.30</b>	6.96	3.76	3.02	2.93	1.58
50							10.70	60.40	32.62	7.87	23.40	12.64	<b>4.78</b>	8.46	4.57	3.35	3.56	1.92
55							11.80	72.55	39.18	8.66	34.00	18.36	<b>5.26</b>	10.10	5.45	3.69	4.24	2.29
60							12.90	84.70	45.74	9.44	39.60	21.38	<b>5.74</b>	11.90	6.43	<b>4.02</b>	4.99	2.69
65							13.95	99.35	53.65	10.23	45.90	24.79	6.21	13.70	7.40	<b>4.36</b>	5.79	3.13
70							15.00	114.00	61.56	11.02	53.00	28.62	6.69	15.80	8.53	<b>4.69</b>	6.64	3.59
75							16.10	129.00	69.66	11.80	60.00	32.40	7.17	17.90	9.67	<b>5.03</b>	7.55	4.08
80							17.20	144.00	77.76	12.59	68.00	36.72	7.65	20.20	10.91	<b>5.36</b>	8.50	4.59
85							18.25	161.50	87.21	13.38	75.00	40.50	8.13	22.60	12.20	<b>5.70</b>	9.51	5.14
90							19.30	179.00	96.66	14.71	84.00	45.36	8.61	25.10	13.55	6.03	10.60	5.72
95										14.95	93.00	50.22	9.08	27.70	14.96	6.37	11.70	6.32
100										15.74	102.00	55.08	9.56	30.50	16.47	6.70	12.80	6.91
110										17.31	122.00	65.88	10.50	36.40	19.66	7.37	15.30	8.26
120										18.89	143.00	77.22	11.50	42.70	23.06	8.04	18.00	9.72
130										20.46	166.00	89.64	12.40	49.60	26.78	8.71	20.90	11.29
140										22.04	190.00	102.60	13.40	56.90	30.73	9.38	23.90	12.91
150										23.60	218.00	117.72	14.30	64.70	34.94	10.00	27.30	14.74
160										25.20	245.00	132.30	15.30	72.80	39.31	10.70	30.70	16.58
170										26.80	275.00	148.50	16.30	81.40	43.96	11.40	34.30	18.52
180										28.40	305.00	164.70	17.20	90.50	48.87	12.10	38.10	20.57
190													18.20	100.00	54.00	12.70	42.10	22.73
200													19.10	110.00	59.40	13.40	46.30	25.00
220													21.00	131.00	70.74	14.70	55.30	29.86
240													22.90	154.00	83.16	16.10	66.40	35.86
260													24.90	179.00	96.66	17.40	75.30	40.66
280													26.80	205.00	110.70	18.80	86.30	46.60
300													28.70	233.00	125.82	20.10	98.10	52.97
320																20.92	103.00	55.62
340																22.22	116.00	62.64
360																23.53	123.00	66.42
380																24.84	142.00	76.68
400																26.80	167.00	90.18
450																30.20	208.00	112.32

Values are for estimating purposes only.

# Friction Loss Charts

## For Water at 60° F per 100 Feet of Pipe

Pipe Size U.S. Gallons Per Min.	3" (3.5" OD) (3.04" ID)			4" (4.5" OD) (4.00" ID)			6" (6.625" OD) (6.03" ID)			8" (8.625" OD) (7.94" ID)			10" (10.75" OD) (9.98" ID)			12" (12.75" OD) (11.89" ID)		
	VEL Ft. Per Sec.	Head Loss Steel	Head Loss Plastic	VEL Ft. Per Sec.	Head Loss Steel	Head Loss Plastic	VEL Ft. Per Sec.	Head Loss Steel	Head Loss Plastic	VEL Ft. Per Sec.	Head Loss Steel	Head Loss Plastic	VEL Ft. Per Sec.	Head Loss Steel	Head Loss Plastic	VEL Ft. Per Sec.	Head Loss Steel	Head Loss Plastic
45	1.95	1.02	0.55															
50	2.17	1.24	0.67															
55	2.39	1.47	0.79															
60	2.60	1.74	0.94															
65	2.82	2.01	1.09															
70	3.04	2.31	1.25	1.76	0.62	0.33												
75	3.25	2.62	1.41	1.91	0.73	0.39												
80	3.47	2.96	1.60	2.02	0.79	0.43												
85	3.69	3.31	1.79	2.17	0.91	0.49												
90	3.91	3.67	1.98	2.27	0.98	0.53												
95	<b>4.12</b>	4.06	2.19	2.42	1.12	0.60												
100	<b>4.34</b>	4.47	2.41	2.52	1.19	0.64												
110	<b>4.77</b>	5.33	2.88	2.77	1.42	0.77												
120	<b>5.21</b>	6.26	3.38	3.02	1.67	0.90												
130	<b>5.64</b>	7.26	3.92	3.28	1.93	1.04												
140	6.08	8.32	4.49	3.53	2.22	1.20	1.56	0.30	0.16									
150	6.51	9.48	5.12	3.78	2.53	1.37	1.70	0.36	0.19									
160	6.94	10.70	5.78	<b>4.03</b>	2.84	1.53	1.78	0.39	0.21									
170	7.71	13.30	7.18	<b>4.29</b>	3.18	1.72	1.92	0.45	0.24									
180	7.81	13.20	7.13	<b>4.54</b>	3.53	1.91	2.00	0.48	0.26									
190	8.63	15.50	8.37	<b>4.79</b>	3.90	2.11	2.16	0.55	0.30									
200	8.68	16.10	8.69	<b>5.05</b>	4.29	2.32	2.22	0.58	0.32									
220	9.55	19.20	10.37	<b>5.55</b>	5.12	2.76	2.44	0.70	0.38									
240	10.40	22.60	12.20	6.05	6.01	3.25	2.67	0.82	0.44									
260	11.30	26.20	14.15	6.55	6.97	3.76	2.89	0.95	0.51									
280	12.20	30.00	16.20	7.08	8.00	4.32	3.11	1.09	0.59	1.80	0.29	0.15						
300	13.00	34.10	18.41	7.57	9.09	4.91	3.33	1.24	0.67	1.92	0.32	0.18						
320	13.90	38.40	20.74	8.07	10.20	5.51	3.56	1.39	0.75	2.05	0.37	0.20						
340	14.80	43.00	23.22	8.58	11.50	6.21	3.78	1.56	0.84	2.18	0.41	0.22						
360	15.60	47.80	25.81	9.08	12.70	6.86	<b>4.00</b>	1.73	0.93	2.30	0.45	0.24						
380	16.50	52.80	28.51	9.59	14.10	7.61	<b>4.22</b>	1.92	1.04	2.43	0.50	0.27						
400	17.40	58.00	31.32	10.10	15.50	8.37	<b>4.44</b>	2.11	1.14	2.57	0.55	0.30	1.63	0.183	0.10			
450	20.40	78.00	42.12	11.49	19.00	10.26	<b>5.00</b>	2.62	1.41	2.88	0.69	0.37	1.83	0.228	0.12			
500	21.70	87.70	47.36	12.60	23.40	12.64	<b>5.56</b>	3.19	1.72	3.20	0.84	0.45	2.04	0.277	0.15			
550	23.90	105.00	56.70	13.90	27.90	15.07	6.11	3.80	2.05	3.52	1.00	0.54	2.24	0.330	0.18			
600	26.00	123.00	66.42	15.10	32.80	17.71	6.66	4.46	2.41	3.85	1.17	0.63	2.44	0.388	0.21			
650	28.20	143.00	77.22	16.40	38.00	20.52	7.22	5.17	2.79	<b>4.17</b>	1.36	0.73	2.64	0.450	0.24			
700				17.60	43.60	23.54	7.78	5.93	3.20	<b>4.49</b>	1.56	0.84	2.85	0.516	0.28			
750				18.90	49.50	26.73	8.34	6.74	3.64	<b>4.81</b>	1.77	0.96	3.06	0.590	0.32			
800				20.20	55.80	30.13	8.90	7.60	4.10	<b>5.13</b>	1.99	1.07	3.25	0.660	0.36			
850				21.40	62.40	33.70	9.45	8.50	4.59	<b>5.45</b>	2.23	1.20	3.47	0.750	0.41			
900				22.70	69.30	37.42	10.00	9.44	5.10	<b>5.77</b>	2.48	1.34	3.66	0.821	0.44	2.56	0.34	0.18
950				24.00	76.60	41.36	10.50	10.20	5.51	6.09	2.74	1.48	3.88	0.910	0.49	2.70	0.33	0.18
1000				25.20	84.30	45.52	11.10	11.50	6.21	6.41	3.02	1.63	<b>4.07</b>	0.998	0.54	2.84	0.41	0.22
1100				27.70	101.00	54.54	12.20	13.70	7.40	7.05	3.60	1.94	<b>4.48</b>	1.190	0.64	3.12	0.50	0.27
1200							13.30	16.10	8.69	7.69	4.23	2.28	<b>4.89</b>	1.400	0.76	3.41	0.58	0.31
1300							14.40	18.60	10.04	8.33	4.90	2.65	<b>5.30</b>	1.620	0.87	3.69	0.67	0.36
1400							15.60	21.40	11.56	8.97	5.62	3.03	<b>5.70</b>	1.86	1.00	3.98	0.77	0.42
1500							16.70	24.30	13.12	9.61	6.39	3.45	6.10	2.11	1.14	<b>4.26</b>	0.88	0.47
1600							17.80	27.40	14.80	10.30	7.20	3.89	6.51	2.38	1.29	<b>4.55</b>	0.99	0.53
1800							20.00	34.10	18.41	11.50	8.95	4.83	7.32	2.96	1.60	<b>5.11</b>	1.23	0.66
2000							22.20	41.40	22.36	12.80	10.90	5.89	8.14	3.60	1.94	<b>5.68</b>	1.50	0.81
2200							24.40	49.40	26.68	14.10	13.00	7.02	8.95	4.29	2.32	6.25	1.78	0.96
2400							26.70	58.00	31.32	15.40	15.20	8.21	9.76	5.04	2.72	6.81	2.10	1.13
2600										16.70	17.70	9.56	10.60	5.84	3.15	7.38	2.43	1.31
2800										18.00	20.30	10.96	11.40	6.70	3.62	7.95	2.78	1.50
3000										19.20	23.00	12.42	12.20	7.61	4.11	8.52	3.17	1.71
3200										20.80	26.80	14.47	13.00	8.58	4.63	9.10	3.51	1.90
3500										22.40	30.60	16.52	14.30	10.08	5.44	9.95	4.21	2.27
3800										24.00	34.90	18.85	15.51	13.40	7.24	10.80	4.90	2.65
4200										27.20	44.00	23.76	16.91	14.75	7.97	11.92	5.83	3.15
4500										28.80	48.80	26.35	18.30	16.10	8.69	12.80	6.70	3.62
5000										32.00	59.30	32.02	20.30	19.60	10.58	14.20	8.15	4.40
5500										35.30	70.70	38.18	22.40	23.40	12.64	15.60	9.72	5.25
6000													24.40	27.50	14.85	17.00	11.40	6.16
6500													26.40	31.80	17.17	18.40	13.20	7.13
7000													28.50	36.50	19.71	19.90	15.20	8.21
7500																22.70	19.40	10.48

Values are for estimating purposes only.

## Friction Loss – Class 160 PVC Pipe

For Water at 60°F per 100 Feet of Pipe

Pipe Size U.S. Gallons Per Min.	3/4"			1" (1.31" OD) (1.19" ID)			1-1/4" (1.66" OD) (1.53" ID)			1-1/2" (1.9" OD) (1.75" ID)			2" (2.37" OD) (2.19" ID)			2-1/2" (2.87" OD) (2.65" ID)		
	VEL Ft. Per Sec.	PSI Loss	Head Loss Ft.	VEL Ft. Per Sec.	PSI Loss	Head Loss Ft.	VEL Ft. Per Sec.	PSI Loss	Head Loss Ft.	VEL Ft. Per Sec.	PSI Loss	Head Loss Ft.	VEL Ft. Per Sec.	PSI Loss	Head Loss Ft.	VEL Ft. Per Sec.	PSI Loss	Head Loss Ft.
2				0.57	0.06	0.14	0.35	0.02	0.05	0.27	0.01	0.02	0.17					
4				1.14	0.23	0.53	0.7	0.07	0.16	0.53	0.04	0.09	0.34	0.01	0.02	0.23		
6				1.71	0.49	1.13	1.04	0.15	0.35	0.8	0.08	0.18	0.51	0.03	0.07	0.35	0.01	0.02
8				2.29	0.84	1.94	1.39	0.25	0.58	1.06	0.13	0.30	0.68	0.04	0.09	0.46	0.02	0.05
10				2.86	1.27	2.93	1.74	0.38	0.88	1.33	0.2	0.46	0.85	0.07	0.16	0.58	0.03	0.07
12				3.43	1.78	4.11	2.09	0.53	1.22	1.59	0.28	0.65	1.02	0.09	0.21	0.69	0.04	0.09
15				<b>4.29</b>	2.7	6.24	2.61	0.8	1.85	1.99	0.42	0.97	1.27	0.14	0.32	0.87	0.06	0.14
18				<b>5.14</b>	3.78	8.73	3.13	1.13	2.61	2.39	0.58	1.34	1.53	0.2	0.46	1.04	0.08	0.18
20				<b>5.71</b>	4.59	10.60	3.48	1.37	3.16	2.65	0.71	1.64	1.7	0.24	0.55	1.16	0.09	0.21
25				7.14	6.94	16.03	<b>4.35</b>	2.07	4.78	3.32	1.07	2.47	2.12	0.36	0.83	1.45	0.14	0.32
30				8.57	9.73	22.48	<b>5.22</b>	2.91	6.72	3.98	1.5	3.46	2.55	0.51	1.18	1.74	0.2	0.46
35				10	12.95	29.91	6.08	3.87	8.94	<b>4.64</b>	2	4.62	2.97	0.67	1.55	2.03	0.27	0.62
40				11.43	16.58	38.30	6.95	4.95	11.43	<b>5.3</b>	2.56	5.91	3.39	0.86	1.99	2.32	0.34	0.78
45				12.86	20.62	47.63	7.82	6.16	14.23	<b>5.9</b>	3.19	7.37	3.82	1.07	2.47	2.6	0.42	0.97
50				14.29	25.07	57.91	8.69	7.48	17.28	6.63	3.87	8.94	<b>4.24</b>	1.31	3.03	2.89	0.52	1.20
55				15.71	29.9	69.07	9.56	8.93	20.63	7.29	4.62	10.67	<b>4.67</b>	1.56	3.60	3.1	0.61	1.41
60				17.14	35.13	81.15	10.43	10.49	24.23	7.96	5.43	12.54	<b>5.09</b>	1.83	4.223	3.47	0.72	1.66
65				18.57	40.75	94.13	11.3	12.16	28.09	8.62	6.3	14.55	<b>5.51</b>	2.12	4.890	3.76	0.84	1.94
70							12.17	13.95	32.22	9.28	7.22	16.68	<b>5.94</b>	2.44	5.64	<b>4.05</b>	0.96	2.22
75							13.04	15.86	36.64	9.95	8.21	18.96	6.36	2.77	6.40	<b>4.34</b>	1.09	2.52
80							13.91	17.87	41.28	10.61	9.25	21.37	6.79	3.12	7.21	<b>4.63</b>	1.23	2.84
85							14.78	19.99	46.18	11.27	10.35	23.90	7.21	3.49	8.06	<b>4.92</b>	1.38	3.19
90							15.65	22.23	51.35	11.94	11.5	26.56	7.64	3.88	8.96	<b>5.21</b>	1.53	3.53
95							16.51	24.57	56.76	12.6	12.72	29.38	8.06	4.29	9.91	<b>5.5</b>	1.69	3.90
100							17.38	27.01	62.39	13.26	13.98	32.29	8.48	4.72	10.90	<b>5.79</b>	1.86	4.30
110							19.12	32.23	74.45	14.59	16.68	38.53	9.33	5.63	13.00	6.37	2.22	5.13
120										15.91	19.6	45.28	10.18	6.61	15.27	6.95	2.61	6.03
130										17.24	22.73	52.51	11.03	7.67	17.72	7.52	3.02	6.98
140										18.57	26.08	60.24	11.88	8.79	20.30	8.1	3.47	8.01
150										19.89	29.63	68.44	12.73	9.99	23.08	8.68	3.94	9.10
160													13.57	11.26	26.01	9.26	4.44	10.26
170													14.42	12.6	29.11	9.84	4.97	11.48
180													15.27	14.01	32.36	10.42	5.52	12.75
190													16.12	15.48	35.76	11	6.11	14.11
200													16.97	17.02	39.32	11.58	6.72	15.52
225													19.09	21.17	48.90	13.02	8.35	19.29
250																14.47	10.15	23.45
275																15.92	12.11	27.97
300																17.36	14.23	32.87
325																18.81	16.5	38.11
350																		
375																		
400																		
425																		
450																		
475																		

Values are for estimating purposes only.

# Friction Loss Charts

## For Water at 60° F per 100 Feet of Pipe

Pipe Size U.S. Gallons Per Min.	3" (3.5" OD) (3.23" ID)			4" (4.5" OD) (4.15" ID)			6" (6.62" OD) (6.11" ID)			8" (8.62" OD) (7.96" ID)			10" (10.75" OD) (9.92" ID)			12" (12.75" OD) (11.77" ID)		
	VEL Ft. Per Sec.	PSI Loss	Head Loss Ft.	VEL Ft. Per Sec.	PSI Loss	Head Loss Ft.	VEL Ft. Per Sec.	PSI Loss	Head Loss Ft.	VEL Ft. Per Sec.	PSI Loss	Head Loss Ft.	VEL Ft. Per Sec.	PSI Loss	Head Loss Ft.	VEL Ft. Per Sec.	PSI Loss	Head Loss Ft.
6	0.23																	
8	0.31	0.01	0.02															
10	0.39	0.01	0.02															
12	0.47	0.01	0.02															
15	0.59	0.02	0.05	0.35	0.01	0.02												
18	0.7	0.03	0.07	0.43	0.01	0.02												
20	0.78	0.04	0.09	0.47	0.01	0.02												
25	0.98	0.05	0.11	0.59	0.02	0.05												
30	1.17	0.08	0.18	0.71	0.02	0.05												
35	1.37	0.1	0.23	0.83	0.03	0.07												
40	1.56	0.13	0.30	0.95	0.04	0.09	0.44	0.01	0.02									
45	1.76	0.16	0.37	1.06	0.05	0.11	0.49	0.01	0.02									
50	1.96	0.2	0.46	1.18	0.06	0.14	0.55	0.01	0.02									
55	2.15	0.24	0.55	1.3	0.07	0.16	0.6	0.01	0.02									
60	2.35	0.28	0.65	1.42	0.08	0.18	0.65	0.01	0.02									
65	2.54	0.32	0.74	1.54	0.09	0.21	0.71	0.01	0.02									
70	2.74	0.37	0.85	1.66	0.11	0.25	0.76	0.02	0.05	0.45								
75	2.93	0.42	0.97	1.77	0.12	0.28	0.82	0.02	0.05	0.48	0.01	0.02						
80	3.13	0.47	1.08	1.89	0.14	0.32	0.87	0.02	0.05	0.52	0.01	0.02						
85	3.32	0.53	1.22	2.01	0.16	0.37	0.93	0.02	0.05	0.55	0.01	0.02						
90	3.52	0.59	1.36	2.13	0.17	0.39	0.98	0.03	0.07	0.58	0.01	0.02						
95	3.72	0.65	1.50	2.25	0.19	0.44	1.04	0.03	0.07	0.61	0.01	0.02						
100	3.91	0.72	1.66	2.36	0.21	0.48	1.09	0.03	0.07	0.64	0.01	0.02						
110	<b>4.3</b>	0.85	1.96	2.6	0.25	0.58	1.2	0.04	0.09	0.71	0.01	0.02						
120	<b>4.69</b>	1	2.31	2.84	0.3	0.69	1.31	0.04	0.09	0.77	0.01	0.02						
130	<b>5.08</b>	1.16	2.68	3.07	0.34	0.78	1.42	0.05	0.11	0.84	0.01	0.02	0.54					
140	<b>5.47</b>	1.34	3.09	3.31	0.39	0.90	1.53	0.06	0.14	0.9	0.02	0.05	0.58	0.01	0.02			
150	<b>5.87</b>	1.52	3.51	3.55	0.45	1.04	1.64	0.07	0.16	0.97	0.02	0.05	0.62	0.01	0.02			
160	6.26	1.71	3.95	3.78	0.5	1.15	1.75	0.08	0.18	1.03	0.02	0.05	0.66	0.01	0.02			
170	6.65	1.91	4.41	<b>4.02</b>	0.56	1.29	1.85	0.09	0.21	1.09	0.02	0.05	0.7	0.01	0.02			
180	7.04	2.13	4.92	<b>4.26</b>	0.63	1.45	1.96	0.1	0.23	1.16	0.03	0.07	0.75	0.01	0.02			
190	7.43	2.35	5.43	<b>4.49</b>	0.69	1.59	2.07	0.11	0.25	1.22	0.03	0.07	0.79	0.01	0.02			
200	7.82	2.59	5.98	<b>4.73</b>	0.76	1.75	2.18	0.12	0.28	1.29	0.03	0.07	0.83	0.01	0.02	0.59		
225	8.8	3.22	7.44	<b>5.32</b>	0.95	2.19	2.45	0.14	0.32	1.45	0.04	0.09	0.93	0.01	0.02	0.66	0.01	0.02
250	9.78	3.91	9.03	<b>5.91</b>	1.15	2.66	2.73	0.18	0.41	1.61	0.05	0.11	1.04	0.02	0.05	0.74	0.01	0.02
275	10.75	4.67	10.79	6.5	1.37	3.16	3	0.21	0.48	1.77	0.06	0.14	1.14	0.02	0.05	0.81	0.01	0.02
300	11.73	5.48	12.66	7.09	1.61	3.72	3.27	0.25	0.58	1.93	0.07	0.16	1.24	0.02	0.05	0.88	0.01	0.02
325	12.71	6.36	14.69	7.68	1.87	4.32	3.55	0.28	0.65	2.09	0.08	0.18	1.35	0.03	0.07	0.96	0.01	0.02
350	13.69	7.29	16.84	8.28	2.14	4.94	3.82	0.33	0.76	2.25	0.09	0.21	1.45	0.03	0.07	1.03	0.01	0.02
375	14.67	8.29	19.15	8.87	2.44	5.64	<b>4.09</b>	0.37	0.85	2.41	0.1	0.23	1.55	0.04	0.09	1.1	0.02	0.05
400	15.64	9.34	21.57	9.46	2.75	6.35	<b>4.36</b>	0.42	0.97	2.58	0.12	0.28	1.66	0.04	0.09	1.18	0.02	0.05
425	16.62	10.45	24.14	10.05	3.07	7.09	<b>4.64</b>	0.47	1.08	2.74	0.13	0.30	1.76	0.04	0.09	1.25	0.02	0.05
450	17.6	11.62	26.84	10.64	3.41	7.88	<b>4.91</b>	0.52	1.20	2.9	0.14	0.32	1.86	0.05	0.11	1.33	0.02	0.05
475	18.58	12.84	29.66	11.23	3.77	8.71	<b>5.18</b>	0.58	1.34	3.06	0.16	0.37	1.97	0.05	0.11	1.4	0.02	0.05
500				11.82	4.15	9.59	<b>5.46</b>	0.63	1.45	3.22	0.18	0.41	2.07	0.06	0.14	1.47	0.03	0.07
550							<b>6</b>	0.75	1.73	3.54	0.21	0.48	2.28	0.07	0.16	1.62	0.03	0.07
600							6.55	0.89	2.05	3.86	0.25	0.56	2.49	0.08	0.18	1.77	0.04	0.09
650							7.09	1.03	2.38	<b>4.18</b>	0.28	0.65	2.69	0.1	0.23	1.91	0.04	0.09
700							7.64	1.18	2.72	<b>4.51</b>	0.33	0.76	2.9	0.11	0.25	2.06	0.05	0.11
750							8.18	1.34	3.09	<b>4.83</b>	0.37	0.85	3.11	0.13	0.30	2.21	0.06	0.14
800							8.73	1.51	3.49	<b>5.15</b>	0.42	0.97	3.31	0.14	0.32	2.36	0.06	0.14
850							9.27	1.69	3.90	<b>5.47</b>	0.47	1.08	3.52	0.16	0.37	2.5	0.07	0.16
900							9.82	1.88	4.34	<b>5.79</b>	0.52	1.20	3.73	0.18	0.41	2.65	0.08	0.18
1000							10.91	2.28	5.27	6.44	0.63	1.45	<b>4.14</b>	0.22	0.51	2.95	0.09	0.21
1100							12	2.72	6.28	7.08	0.75	1.73	<b>4.56</b>	0.26	0.60	3.24	0.11	0.25
1200							13.09	3.2	7.39	7.73	0.89	2.05	<b>4.97</b>	0.3	0.69	3.53	0.13	0.30
1300							14.18	3.71	8.57	8.37	1.03	2.38	<b>5.39</b>	0.35	0.81	3.83	0.15	0.35
1400							15.28	4.26	9.84	9.01	1.18	2.72	<b>5.8</b>	0.4	0.92	<b>4.12</b>	0.18	0.41
1500							16.37	4.84	11.18	9.66	1.34	3.09	6.21	0.46	1.06	<b>4.42</b>	0.2	0.46
1600							17.46	5.45	12.59	10.3	1.51	3.47	6.63	0.52	1.20	<b>4.71</b>	0.23	0.53
1700							18.55	6.1	14.09	10.94	1.69	3.90	7.04	0.58	1.34	<b>5.01</b>	0.25	0.58
1800							19.64	6.78	15.66	11.59	1.88	4.34	7.46	0.64	1.48	<b>5.3</b>	0.28	0.65
1900										12.23	2.08	4.80	7.87	0.71	1.64	<b>5.6</b>	0.31	0.71
2000										12.88	2.28	5.27	8.29	0.78	1.80	<b>5.89</b>	0.34	0.78
2200										14.16	2.72	6.28	9.11	0.93	2.15	6.48	0.41	0.95
2400										15.45	3.2	7.39	9.94	1.09	2.52	7.07	0.48	1.11
2600										16.74	3.71	8.57	10.77	1.27	2.93	7.66	0.55	1.27
2800										18.03	4.26	9.84	11.6	1.46	3.37	8.25	0.64	1.48
3000										19.31	4.84	11.18	12.43	1.66	3.83	8.84	0.72	1.66
3200													13.26	1.87	4.32	9.42	0.81	1.87
3400													14.09	2.09	4.83	10.01	0.91	2.10
3600													14.91	2.32	5.36	10.6	1.01	2.33
3800													15.74	2.56	5.91	11.19	1.12	2.59
4000													16.57	2.82	6.51	11.78	1.23	2.84
4500													18.64	3.51	8.10	13.25	1.53	3.53
5000																14.73	1.86	4.30
6000																17.67	2.6	6.01
6500																		
7000																		
7500																		

Values are for estimating purposes only.

## Friction Loss – Class 200 PVC Pipe

For Water at 60°F per 100 Feet of Pipe

Pipe Size U.S. Gallons Per Min.	3/4" (1.05" OD) (.93" ID)			1" (1.31" OD) (1.19" ID)			1-1/4" (1.66" OD) (1.50" ID)			1-1/2" (1.9" OD) (1.72" ID)			2" (2.37" OD) (2.15" ID)			2-1/2" (2.87" OD) (2.60" ID)		
	VEL Ft. Per Sec.	PSI Loss	Head Loss Ft.	VEL Ft. Per Sec.	PSI Loss	Head Loss Ft.	VEL Ft. Per Sec.	PSI Loss	Head Loss Ft.	VEL Ft. Per Sec.	PSI Loss	Head Loss Ft.	VEL Ft. Per Sec.	PSI Loss	Head Loss Ft.	VEL Ft. Per Sec.	PSI Loss	Head Loss Ft.
2	0.94	0.22	0.51	0.58	0.07	0.16	0.36	0.02	0.05	0.28	0.01	0.02	0.18					
4	1.89	0.79	1.82	1.15	0.24	0.55	0.72	0.08	0.18	0.55	0.04	0.09	0.35	0.01	0.02	0.24	0.01	0.02
6	2.83	1.68	3.88	1.73	0.51	1.18	1.09	0.16	0.37	0.83	0.08	0.18	0.53	0.03	0.07	0.36	0.01	0.02
8	3.77	2.85	6.58	2.31	0.86	1.99	1.45	0.28	0.65	1.1	0.14	0.32	0.71	0.05	0.11	0.48	0.02	0.05
10	<b>4.72</b>	4.31	9.96	2.89	1.3	3.00	1.81	0.42	0.97	1.38	0.22	0.51	0.88	0.07	0.16	0.6	0.03	0.07
12	<b>5.66</b>	6.05	13.97	3.46	1.83	4.23	2.17	0.59	1.36	1.65	0.3	0.69	1.06	0.1	0.23	0.72	0.04	0.09
15	7.08	9.13	21.09	<b>4.33</b>	2.76	6.37	2.71	0.89	2.05	2.07	0.46	1.06	1.33	0.16	0.37	0.9	0.06	0.14
18	8.49	12.81	29.59	<b>5.19</b>	3.87	8.94	3.26	1.24	2.86	2.48	0.64	1.48	1.59	0.22	0.51	1.09	0.09	0.21
20	9.43	15.58	35.99	<b>5.77</b>	4.71	10.88	3.62	1.51	3.47	2.76	0.78	1.80	1.77	0.26	0.60	1.21	0.1	0.23
25	11.79	23.52	54.33	7.22	7.12	16.45	<b>4.52</b>	2.28	5.27	3.45	1.18	2.72	2.21	0.4	0.92	1.51	0.16	0.37
30	14.15	33	76.23	8.66	9.97	23.03	<b>5.43</b>	3.2	7.39	<b>4.14</b>	1.65	3.81	2.65	0.56	1.29	1.81	0.22	0.51
35	16.51	43.91	101.43	10.1	13.27	30.65	6.33	4.26	9.84	<b>4.83</b>	2.2	5.08	3.09	0.74	1.71	2.11	0.29	0.67
40	18.87	56.23	129.89	11.54	16.99	39.25	7.23	5.45	12.59	<b>5.52</b>	2.82	6.51	3.53	0.95	2.19	2.41	0.38	0.88
45				12.99	21.13	48.81	8.14	6.78	15.66	6.21	3.51	8.11	3.98	1.19	2.75	2.71	0.47	1.08
50				14.43	25.69	59.34	9.04	8.24	19.03	6.9	4.26	9.84	<b>4.42</b>	1.44	3.33	3.02	0.57	1.32
55				15.87	30.65	70.80	9.95	9.83	22.71	7.59	5.08	11.73	<b>4.86</b>	1.72	3.97	3.32	0.68	1.57
60				17.32	36	83.16	10.85	11.55	26.68	8.27	5.97	13.79	<b>5.3</b>	2.02	4.67	3.62	0.8	1.85
65				18.76	41.76	96.46	11.76	13.39	30.93	8.96	6.93	16.01	<b>5.74</b>	2.34	5.40	3.92	0.93	2.15
70							12.66	15.36	35.48	9.65	7.95	18.36	6.18	2.69	6.21	<b>4.22</b>	1.06	2.45
75							13.56	17.46	40.33	10.34	9.03	20.86	6.63	3.05	7.04	<b>4.52</b>	1.21	2.79
80							14.47	19.67	45.44	10.38	10.17	23.49	7.07	3.44	7.95	<b>4.82</b>	1.36	3.14
85							15.37	22.01	50.84	11.72	11.38	26.29	7.51	3.85	8.89	<b>5.13</b>	1.52	3.51
90							16.28	24.47	56.52	12.41	12.65	29.22	7.95	4.28	9.87	<b>5.43</b>	1.69	3.90
95							17.18	27.05	62.48	13.1	13.99	32.32	8.39	4.73	10.93	<b>5.73</b>	1.87	4.32
100							18.09	29.74	68.70	13.79	15.38	35.53	8.83	5.2	12.01	6.03	2.06	4.76
110							19.89	35.48	81.96	15.17	18.35	42.39	9.72	6.21	14.34	6.63	2.45	5.66
120										16.55	21.56	49.80	10.6	7.3	16.86	7.24	2.88	6.65
130										17.93	25	57.75	11.48	8.46	19.54	7.84	3.34	7.71
140										19.31	28.68	66.25	12.37	9.71	22.43	8.44	3.83	8.85
150													13.25	11.03	25.48	9.05	4.36	10.07
160																		
170																		
175													15.46	14.67	33.89	10.55	5.8	13.40
180																		
190																		
200													17.67	18.79	43.40	12.06	7.42	17.14
225													19.88	23.37	53.98	13.57	9.23	21.32
250																15.08	11.22	25.92
275																16.58	13.39	30.93
300																18.09	15.73	36.34
325																		
350																		
375																		
400																		
450																		
500																		

Values are for estimating purposes only.

# Friction Loss Charts

## For Water at 60° F per 100 Feet of Pipe

Pipe Size U.S. Gallons Per Min.	3" (3.5" OD) (3.17" ID)			4" (4.5" OD) (4.07" ID)			6" (6.62" OD) (5.99" ID)			8" (8.62" OD) (7.80" ID)			10" (10.75" OD) (9.73" ID)			12" (12.75" OD) (11.54" ID)		
	VEL Ft. Per Sec.	PSI Loss	Head Loss Ft.	VEL Ft. Per Sec.	PSI Loss	Head Loss Ft.	VEL Ft. Per Sec.	PSI Loss	Head Loss Ft.	VEL Ft. Per Sec.	PSI Loss	Head Loss Ft.	VEL Ft. Per Sec.	PSI Loss	Head Loss Ft.	VEL Ft. Per Sec.	PSI Loss	Head Loss Ft.
6	0.24																	
8	0.33	0.01	0.02															
10	0.41	0.01	0.02															
12	0.49	0.02	0.05	0.3														
15	0.61	0.02	0.05	0.37	0.01	0.02												
18	0.73	0.03	0.07	0.44	0.01	0.02												
20	0.81	0.04	0.07	0.49	0.01	0.02												
25	1.02	0.06	0.14	0.62	0.02	0.05												
30	1.22	0.08	0.18	0.74	0.02	0.05												
35	1.42	0.11	0.25	0.86	0.03	0.07												
40	1.63	0.14	0.32	0.98	0.04	0.09	0.45	0.01	0.02									
45	1.8	0.18	0.41	1.11	0.05	0.11												
50	2.04	0.22	0.51	1.23	0.06	0.14	0.57	0.01	0.02									
55	2.24	0.26	0.60	1.35	0.08	0.18	0.62	0.01	0.02									
60	2.44	0.31	0.72	1.48	0.09	0.21	0.68	0.01	0.02									
65	2.65	0.36	0.83	1.6	0.1	0.23	0.74	0.02	0.05	0.44								
70	2.85	0.41	0.95	1.72	0.12	0.28	0.8	0.02	0.05	0.47	0.01	0.02						
75	3.05	0.46	1.06	1.85	0.14	0.32	0.85	0.02	0.05	0.5	0.01	0.02						
80	3.26	0.52	1.20	1.97	0.15	0.35	0.91	0.02	0.05	0.54	0.01	0.02						
85	3.46	0.58	1.34	2.09	0.17	0.39	0.97	0.03	0.07	0.57	0.01	0.02						
90	3.66	0.65	1.50	2.21	0.19	0.44	1.02	0.03	0.07	0.6	0.01	0.02						
95	3.87	0.72	1.66	2.34	0.21	0.48	1.08	0.03	0.07	0.64	0.01	0.02						
100	<b>4.07</b>	0.79	1.82	2.46	0.23	0.53	1.14	0.04	0.09	0.67	0.01	0.02						
110	<b>4.48</b>	0.94	2.17	2.71	0.28	0.65	1.25	0.04	0.09	0.74	0.01	0.02						
120	<b>4.88</b>	1.11	2.56	2.95	0.33	0.76	1.36	0.05	0.11	0.8	0.01	0.02	0.52					
130	<b>5.29</b>	1.28	2.96	3.2	0.38	0.88	1.48	0.06	0.14	0.87	0.02	0.05	0.56	0.01	0.02			
140	<b>5.7</b>	1.47	3.39	3.44	0.43	0.99	1.59	0.07	0.16	0.94	0.02	0.05	0.6	0.01	0.02			
150	6.11	1.67	3.86	3.69	0.49	1.13	1.7	0.08	0.18	1	0.02	0.05	0.65	0.01	0.02			
160							1.82	0.08	0.18	1.07	0.02	0.05	0.69	0.01	0.02			
170							1.93	0.09	0.21	1.14	0.03	0.07	0.73	0.01	0.02			
175	7.12	2.23	5.15	<b>4.31</b>	0.65	1.50												
180							2.04	0.11	0.25	1.21	0.03	0.07	0.78	0.01	0.02			
190							2.16	0.12	0.28	1.27	0.03	0.07	0.82	0.01	0.02	0.58		
200	8.14	2.85	6.58	<b>4.92</b>	0.84	1.94	2.27	0.13	0.30	1.34	0.04	0.09	0.86	0.01	0.02	0.61	0.01	0.02
225	9.16	3.55	8.20	<b>5.54</b>	1.04	2.40	2.56	0.16	0.37	1.51	0.04	0.09	0.97	0.02	0.05	0.69	0.01	0.02
250	10.18	4.31	9.96	6.15	1.27	2.93	2.84	0.19	0.44	1.67	0.05	0.11	1.08	0.02	0.05	0.77	0.01	0.02
275	11.19	5.14	11.87	6.77	1.51	3.49	3.12	0.23	0.53	1.84	0.06	0.14	1.19	0.02	0.05	0.84	0.01	0.02
300	12.21	6.04	13.95	7.38	1.78	4.11	3.41	0.27	0.62	2.01	0.07	0.16	1.29	0.03	0.07	0.92	0.01	0.02
325							3.69	0.31	0.71	2.18	0.09	0.21	1.4	0.03	0.07	1	0.01	0.02
350	14.25	8.04	18.57	8.61	2.36	5.45	3.98	0.36	0.83	2.34	0.1	0.23	1.51	0.03	0.07	1.07	0.01	0.02
375							<b>4.26</b>	0.41	0.94	2.51	0.11	0.25	1.62	0.04	0.09	1.15	0.02	0.05
400	16.28	10.29	23.77	9.84	3.03	7.0	<b>4.54</b>	0.46	1.06	2.68	0.13	0.30	1.72	0.04	0.09	1.23	0.02	0.05
450	18.32	12.8	29.57	11.07	3.76	8.68	<b>5.11</b>	0.57	1.32	3.01	0.16	0.37	1.94	0.05	0.11	1.38	0.02	0.05
500				12.3	4.57	10.56	<b>5.68</b>	0.7	1.62	3.35	0.19	0.44	2.16	0.07	0.16	1.53	0.03	0.07
550				13.53	5.46	12.61	6.25	0.83	1.92	3.68	0.23	0.53	2.37	0.08	0.18	1.69	0.03	0.07
600				14.76	6.41	14.81	6.82	0.98	2.26	<b>4.02</b>	0.27	0.62	2.59	0.09	0.21	1.84	0.04	0.07
650							7.38	1.13	2.61	<b>4.35</b>	0.31	0.72	2.8	0.11	0.25	1.99	0.05	0.11
700				17.22	8.53	19.70	7.95	1.3	3.00	<b>4.69</b>	0.36	0.83	3.02	0.12	0.28	2.15	0.05	0.11
750							8.52	1.48	3.42	<b>5.02</b>	0.41	0.95	3.23	0.14	0.32	2.3	0.06	0.14
800				19.68	10.92	25.22	9.09	1.67	3.86	<b>5.36</b>	0.46	1.06	3.45	0.16	0.37	2.45	0.07	0.16
850							9.66	1.86	4.30	<b>5.69</b>	0.52	1.20	3.66	0.18	0.41	2.61	0.08	0.184
900							10.22	2.07	4.78	6.03	0.57	1.32	3.88	0.2	0.46	2.76	0.09	0.21
950							10.79	2.29	5.29	6.36	0.63	1.45	<b>4.1</b>	0.22	0.51	2.91	0.09	0.21
1000							11.36	2.52	5.82	6.7	0.7	1.62	<b>4.31</b>	0.24	0.55	3.06	0.1	0.23
1100							12.5	3	6.93	7.37	0.83	1.92	<b>4.74</b>	0.28	0.65	3.37	0.12	0.28
1200							13.63	3.53	8.15	8.04	0.98	2.26	<b>5.17</b>	0.33	0.76	3.68	0.15	0.35
1300							14.77	4.09	9.45	8.71	1.13	2.61	<b>5.6</b>	0.39	0.90	3.98	0.17	0.39
1400							15.9	4.7	10.86	9.38	1.3	3.00	6.04	0.44	1.02	<b>4.29</b>	0.19	0.44
1500							17.04	5.34	12.33	10.05	1.48	3.42	6.47	0.51	1.18	<b>4.6</b>	0.22	0.51
1600							18.18	6.01	13.88	10.72	1.66	3.83	6.9	0.57	1.317	<b>4.9</b>	0.25	0.58
1700							19.31	6.73	15.55	11.39	1.86	4.30	7.33	0.64	1.48	<b>5.21</b>	0.28	0.65
1800										12.06	2.07	4.78	7.76	0.71	1.64	<b>5.52</b>	0.31	0.72
1900										12.73	2.29	5.29	8.19	0.78	1.80	<b>5.82</b>	0.34	0.78
2000										13.4	2.51	5.80	8.62	0.86	1.99	6.13	0.38	0.88
2200										14.73	3	6.93	9.48	1.03	2.38	6.74	0.45	1.04
2400										16.07	3.52	8.13	10.35	1.21	2.79	7.36	0.53	1.22
2600										17.41	4.09	9.45	11.21	1.4	3.23	7.97	0.61	1.41
2800										18.75	4.69	10.83	12.07	1.6	3.70	8.58	0.7	1.61
3000													12.93	1.82	4.20	9.19	0.79	1.82
3200													13.8	2.06	4.76	9.81	0.9	2.08
3400													14.66	2.3	5.31	10.42	1	2.31
3600													15.52	2.56	5.91	11.03	1.11	2.56
3800													16.38	2.83	6.54	11.65	1.23	2.84
4000													17.25	3.11	7.18	12.26	1.35	3.12
4500													19.4	3.86	8.92	13.79	1.68	3.88
5000																15.32	2.05	4.73
5500																16.86	2.44	5.64
6000																18.39	2.87	6.63
6500																19.92	3.33	7.69

Values are for estimating purposes only.

# Wire Size Chart 24V

24V Power Required W(VA)/Amps	Wire Gauge									
	8awg	10awg	12awg	14awg	16awg	18awg	20awg	22awg	24awg	26awg
3W/.13A	14,417	9,253	5,823	3,656	2,299	1,451	905	565	356	226
4W/.17A	11,025	7,076	4,453	2,796	1,758	1,110	692	432	274	173
5W/.21A	8,925	5,728	3,605	2,263	1,423	898	560	350	222	40
10W/.42A	4,463	2,864	1,803	1,132	712	449	280	175	111	70
20W/.83A	2,258	1,449	912	573	360	227	142	89	56	35
30W/1.25A	1,499	962	606	380	239	151	94	59	37	24
40W/1.67A	1,122	720	453	285	179	113	70	44	28	16
50W/2.08A	901	578	364	229	144	91	57	35	22	14
60W/2.50A	750	481	303	190	120	75	47	29	19	12

the recommended maximum distances for 24volts, ac or dc, is the cell below the wire size, adjacent to watts (VA) or required current

# Wire Size Chart - Single Phase

Motor Rating	Circuit Size	Fuse Size	Full Load Amps	Copper Wire Size														
				KW	12	10	8	6	4	2	0	00	000	0000	250	300	350	
120 (1Ø)	1/4	20	10	5.8	0.186	291	464	692	1171	1863	2350	3737	4715	5942	7492			
	1/3	20	10	7.2	0.246	230	365	546	924	1471	2338	3721	4691	5914	7457	8811		
	1/2	20	15	9.8	0.373	171	272	407	689	1096	1742	2773	3495	4406	5556	6565		
	3/4	20	15	13.8	0.559	130	207	310	524	834	1326	2110	2660	3354	4229	4997		
	1	20	20	16	0.746	99	157	236	399	635	1009	1607	2025	2553	3220	3804		
	1-1/2	30	25	20	1.12		128	192	325	515	822	1309	1650	2080	2624	3100		
	2	30	40	24	1.49			134	226	360	573	912	1150	1449	1828	2160	2592	
208 (1Ø)	1/4	20	5	2.9	0.186	1166	1853	2769	4685	7453	11850							
	1/3	20	5	3.6	0.246	920	1462	2186	3699	5884	9355							
	1/2	20	8	4.9	0.373	650	1025	1550	2620	4160	6610	10530	13250					
	3/4	20	8	7	0.559	490	785	1175	1990	3170	5040	8020	10109	12745				
	1	20	10	9	0.746	360	600	895	1515	2410	3835	6105	7695	9705	1225			
	1-1/2	20	15	11	1.12	250	405	605	1025	1635	2595	4130	5205	6568	9230			
	2	20	20	12	1.49	240	385	585	985	1573	2500	3980	5015	6325	7975			
	2-1/2	30	20	14	1.9	205	325	495	840	1335	2125	3575	4510	5690	7175			
	3	30	25	18	2.24	175	275	415	700	1115	1775	2825	3560	4495	5665			
	5	40	35	29	3.73		185	280	475	755	1205	1920	2415	3050	3845			
240 (1Ø)	1/4	20	5	2.9	0.186	1166	1853	2769	4685	7453	11850	18857						
	1/3	20	5	3.6	0.246	920	1462	2186	3699	5884	9355	14887	18764					
	1/2	20	8	4.9	0.373	685	1090	1629	2756	4384	6970	11092	13981					
	3/4	20	8	6.9	0.559	522	829	1240	2098	3337	5305	8443	10642	13416				
	1	20	10	8	0.746	397	631	944	1597	2540	4039	6428	8102	10215	12881			
	1-1/2	20	15	10	1.12	269	427	639	1081	1720	2734	4351	5484	6914	8719			
	2	20	20	12	1.49	259	411	615	1041	1656	2633	4190	5281	6658	8398			
	2-1/2	30	20	11.6	1.9	220	344	522	885	1407	2238							
	3	30	25	17	2.24	184	292	437	739	1176	1871	2977	3752	4731	5966			
	5	40	30	28	3.73		198	296	502	798	1269	2020	2546	3210	4048			
	7-1/2	50	45	40	5.59			218	369	588	935	1488	1876	2365	2983	3524		
	10	60	60	50	7.46				286	456	725	1153	1455	1834	2313	2733	3279	

Values are for estimating purposes only and may not meet NEC code. Design should be verified.



# Conversion Tables

## FRACTION TO DECIMAL CONVERSION TABLE

1/3 = .33	2/3 = .6				
1/4 = .25	3/4 = .75				
1/5 = .20	2/5 = .4	3/5 = .6	4/5 = .8		
1/6 = .16	5/6 = 0.83				
1/7 = .142857	2/7 = .285714	3/7 = .428571	4/7 = .571428	5/7 = .714285	6/7 = .857142
1/8 = .125	3/8 = .375	5/8 = .625	7/8 = .875		
1/9 = .1	2/9 = .2	4/9 = .4	5/9 = .5	7/9 = .7	8/9 = .8
1/10 = .1	3/10 = .3	7/10 = .7	9/10 = .9		
1/11 = .09	2/11 = .18	3/11 = .27	4/11 = .36	5/11 = .45	6/11 = .54
	7/11 = .63	8/11 = .72	9/11 = .81	10/11 = .90	
1/12 = .083	5/12 = .416	7/12 = .583	11/12 = .916		
1/16 = 0.0625	3/16 = .1875	5/16 = .3125	7/16 = .4375	11/16 = .6875	13/16 = .8125
	15/16 = .9375				
1/32 = 0.03125	3/32 = .09375	5/32 = .15625	7/32 = .21875	9/32 = .28125	11/32 = .34375
	13/32 = .40625	15/32 = .46875	17/32 = .53125	19/32 = .59375	21/32 = .65625
	23/32 = .71875	25/32 = .78125	27/32 = .84375	29/32 = .90625	31/32 = .96875

Circumference of circle = 3.1416 x dia = 6.2832 x radius • Area of circle = .7854 x (dia)<sup>2</sup> = 3.1416 x (radius)<sup>2</sup> • Area of Sphere = 3.1416 x (dia)<sup>2</sup> • Volume of Sphere = .5236 x (dia)<sup>3</sup> • 1 lb per sq in is equivalent to .06804 atmospheres.

Important Note: Any span of numbers that are underlined signifies that those numbers are repeated. For example, 0.09 signifies 0.090909. Only fractions in the lowest terms are listed. For instance, to find 2/8, first simplify it to 1/4 then search for it in the table above.

## PARTICLE SIZE TABLE

Inch	Millimeter	Microns	Mesh
0.00	--	25	--
0.0015	--	37	400
0.002	--	50	300
0.003	--	75	200
0.004	1/10	100	150
0.005	1/8	125	115
0.006	--	149	100
0.007	--	177	80
0.010	1/4	250	60
0.011	--	280	50
0.016	--	406	40
0.020	1/2	500	--
0.021	--	533	30
0.030	3/4	750	--
0.033	--	838	--
0.034	--	840	20
0.039	1	1000	16
0.045	--	1143	--
0.046	--	1190	14
0.055	--	1410	12
0.059	1 1/2	1500	--
0.062	--	1575	--
0.065	--	1680	10
0.079	2	2000	9
0.093	--	2380	8
0.094	--	2388	--
0.110	--	2790	7
0.118	3	3000	--
0.125	--	3175	--
0.131	--	3330	6
0.156	4	4000	5
0.185	--	4700	4
0.1875	--	4763	--
0.197	5	5000	--
0.236	6	6000	--
0.250	--	6350	--
0.263	--	6700	3

## HOW MUCH IS THAT?

1 US bushel	= 1.24 cu feet	1 BR bushel	= 1.284 cu feet
1 peck	= 1/4 bushel	1 mil. gallons per day	= 694.4 gpm
1 pottle	= 2 quarts	1 comb	= 4 bushels
1 wey	= 4 bushels	1 last	= 80 bushels
1 US gallon	= 128 fl ounces	1 BR gallon	= 1.28 US gallons
1 firkin	= 9 gallons	1 butt	= 108 gallons
1 puncheon	= 84 gallons	1 tierce	= 42 gallons
1 pipe	= 108 gallons	1 hogshead	= 54 gallons
1 runlet	= 18 gallons	1 gill	= 4 ounces
1 furlong	= 660 feet	1 chain	= 66 feet
1 hand	= 4 inches	1 rod	= 16.5 feet
1 perch	= 8 feet	1 fathom	= 6 feet
1 stat. mile	= 5280 feet	1 naut. mile	= 6076 feet
1 US ton	= 2000 lbs	1 BR ton	= 2200 lbs
1 metric ton	= 2240 lbs	1 stone	= 14 lbs
1 mech. horsepower	= 33000 ft-lb/min	1 royal cubit	= 20.62 inches
1 drum fluid	= 55 gallons	1 barrel fluid	= 31.5 gallons

METRIC CONVERSION TABLE					
To Convert From	To	Multiply By	To Convert From	To	Multiply By
<b>Length</b>			<b>Length</b>		
mm	inches	.03937	inches	mm	25.40
cm	inches	.3937	inches	cm	2.540
meters	inches	39.37	inches	meters	.0254
meters	feet	3.281	feet	meters	.3048
meters	yards	1.0936	feet	km	.0003048
km	feet	3280.8	yards	meters	.9144
km	yards	1093.6	yards	km	.0009144
km	miles	.6214	miles	km	1.609
<b>Area</b>			<b>Area</b>		
sq mm	sq inches	.00155	sq inches	sq mm	645.2
sq cm	sq inches	.155	sq inches	sq cm	6.452
sq meters	sq feet	10.764	sq feet	sq meters	.09290
sq meters	sq yards	1.196	sq yards	sq meters	.8361
sq km	sq miles	.3861	sq miles	sq km	2.590
hectares	acres	2.471	acres	hectares	.4047
<b>Volume</b>			<b>Volume</b>		
cu cm	cu inches	.06102	cu inches	cu cm	16.387
cu cm	fl ounces	.0338	cu inches	liters	.01639
cu meters	cu feet	35.314	cu feet	cu meters	.02832
cu meters	cu yards	1.308	cu feet	liters	28.317
cu meters	US gallons	264.2	cu yards	cu meters	.7646
liters	cu inches	61.023	fl ounces	cu cm	29.57
liters	cu feet	.03531	US gallon	cu meters	.003785
liters	US gallons	.2642	US gallon	liters	3.785
<b>Weight</b>			<b>Weight</b>		
grams	grains	15.432	grains	grams	.0648
grams	ounces	.0353	ounces	grams	28.350
kg	ounces	35.27	ounces	kg	.02835
kg	pounds	2.2046	pounds	kg	.4536
kg	US tons	.001102	US tons	kg	907.2
<b>Unit Weight</b>			<b>Unit Weight</b>		
gr/sq cm	lb/sq in	.01422	lb/ft	kg/m	1.4881
gr/cu cm	lb/cu in	.0361	lb/sq in	gr/sq cm	70.31
kg/sq cm	lb/sq in	14.22	lb/sq in	kg/sq cm	.07031
kg/cu m	lb/cu ft	.0624	lb/cu in	gr/cu cm	27.68
kg/m	lb/ft	.6720	lb/cu ft	kg/cu m	16.018
<b>Unit Volume</b>			<b>Unit Volume</b>		
liters/min	US gpm	.2642	US gpm	liters/min	3.785
liters/min	cfm	.03531	US gpm	liters/hr	227.1
liters/hr	US gpm	.0044	US gpm	cu m/hr	.2271
cu m/min	cfm	35.314	cfm	liters/min	28.317
cu m/hr	cfm	.5886	cfm	cu m/min	.02832
cu m/hr	US gpm	4.4028	cfm	cu m/hr	1.6992
<b>Power</b>			<b>Power</b>		
watts	ft-lb/sec	.7376	ft-lb/sec	watts	1.356
watts	hp	.00134	hp	watts	745.7
kw	hp	1.3410	hp	kw	.7457
cheval-vap	hp	.9863	hp	cheval-vap	1.0139

ENGLISH CONVERSION TABLE					
<b>Length</b>			<b>Volume</b>		
inches	feet	.0833	cu inches	cu feet	.0005787
inches	yards	.0278	cu inches	cu yards	.00002143
feet	inches	12	cu inches	US gallon	.004329
feet	yards	.3333	cu feet	cu inches	1728
feet	miles	.0001894	cu feet	cu yards	.03704
yards	feet	3	cu feet	US gallon	7.481
yards	miles	.0005682	cu yards	cu feet	27
<b>Area</b>			<b>Weight</b>		
sq inches	sq feet	.00694	grains	ounces	.002286
sq inches	sq yards	.000772	ounces	grains	437.5
sq feet	sq inches	144	ounces	pounds	.0625
sq feet	sq yards	.11111	pounds	ounces	16
sq yards	sq inches	1296	pounds	US tons	.0005
sq yards	sq feet	9	pounds	long tons	.000446
sq yards	acres	.000207	US tons	pounds	2000
acres	sq feet	43560	long tons	pounds	2240

## Decimal Equivalent Chart

Fraction	Decimals	Millimeters	Fraction	Decimals	Millimeters	MM	Inches	MM	Inches
1/64	.15625	0.397	33/64	.515625	13.097	.1	.0039	46	1.8110
1/32	.03125	0.794	17/32	.53125	13.494	.2	.0079	47	1.8504
3/64	.046875	1.191	35/64	.546875	13.891	.3	.0118	48	1.8898
<b>1/16</b>	<b>.0625</b>	<b>1.588</b>	<b>9/16</b>	<b>.5625</b>	<b>14.288</b>	.4	.0157	49	1.9291
5/64	.078125	1.984	37/64	.578125	14.684	.5	.0197	50	1.9685
3/32	.09375	2.381	19/32	.59375	15.081	.6	.0236	51	2.0079
7/64	.109375	2.778	39/64	.609375	15.478	.7	.0276	52	2.0472
<b>1/8</b>	<b>.1250</b>	<b>3.175</b>	<b>5/8</b>	<b>.6250</b>	<b>15.875</b>	.8	.0315	53	2.0866
9/64	.140625	3.572	41/64	.640625	16.272	.9	.0354	54	2.1260
5/32	.15625	3.969	21/32	.65625	16.669	1	.0394	55	2.1654
11/64	.171875	4.366	43/64	.671875	17.066	2	.0787	56	2.2047
<b>3/16</b>	<b>.1875</b>	<b>4.763</b>	<b>11/16</b>	<b>.6875</b>	<b>17.463</b>	3	.1181	57	2.2441
13/64	.203125	5.159	45/64	.703125	17.859	4	.1575	58	2.2835
7/32	.21875	5.556	23/32	.71875	18.256	5	.1969	59	2.3228
15/64	.234375	5.953	47/64	.734375	18.653	6	.2362	60	2.3622
<b>1/4</b>	<b>.2500</b>	<b>6.350</b>	<b>3/4</b>	<b>.7500</b>	<b>19.050</b>	7	.2756	61	2.4016
17/64	.265625	6.747	49/64	.765625	19.447	8	.3150	62	2.4409
9/32	.28125	7.144	25/32	.78125	19.844	9	.3543	63	2.4803
19/64	.296875	7.541	51/64	.796875	20.241	10	.3937	64	2.5197
<b>5/16</b>	<b>.3125</b>	<b>7.938</b>	<b>13/16</b>	<b>.8125</b>	<b>20.638</b>	11	.4331	65	2.5591
21/64	.328125	8.334	53/64	.828125	21.034	12	.4724	66	2.5984
11/32	.34375	8.731	27/32	.84375	21.431	13	.5118	67	2.6378
23/64	.359375	9.128	55/64	.859375	21.828	14	.5512	68	2.6772
<b>3/8</b>	<b>.3750</b>	<b>9.525</b>	<b>7/8</b>	<b>.8750</b>	<b>22.225</b>	15	.5906	69	2.7165
25/64	.390625	9.922	57/64	.890625	22.622	16	.6299	70	2.7559
13/32	.40625	10.319	29/32	.90625	23.019	17	.6693	71	2.7953
27/64	.421875	10.716	59/64	.921875	23.416	18	.7087	72	2.8346
<b>7/16</b>	<b>.4375</b>	<b>11.113</b>	<b>15/16</b>	<b>.9375</b>	<b>23.813</b>	19	.7480	73	2.8740
29/64	.453125	11.509	61/64	.953125	24.209	20	.7874	74	2.9134
15/32	.46875	11.906	31/32	.96875	24.606	21	.8268	75	2.9528
31/64	.484375	12.303	63/64	.984375	25.003	22	.8661	76	2.9921
<b>1/2</b>	<b>.5000</b>	<b>12.700</b>	<b>1</b>	<b>1.000</b>	<b>25.400</b>	23	.9055	77	3.0315
						24	.9449	78	3.0709
						25	.9843	79	3.1102
						26	1.0236	80	3.1496
						27	1.0630	81	3.1890
						28	1.1024	82	3.2283
						29	1.1417	83	3.2677
						30	1.1811	84	3.3071
						31	1.2205	85	3.3465
						32	1.2598	86	3.3858
						33	1.2992	87	3.4242
						34	1.3386	88	3.4646
						35	1.3780	89	3.5039
						36	1.4173	90	3.5433
						37	1.4567	91	3.5827
						38	1.4961	92	3.6220
						39	1.5354	93	3.6614
						40	1.5748	94	3.7008
						41	1.6124	95	3.7402
						42	1.6535	96	3.7795
						43	1.6929	97	3.8189
						44	1.7323	98	3.8583
						45	1.7717	99	3.8976
								100	3.9370

# Measuring Tools

---

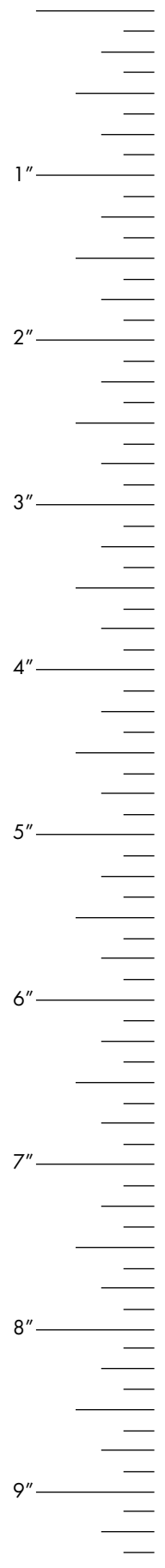
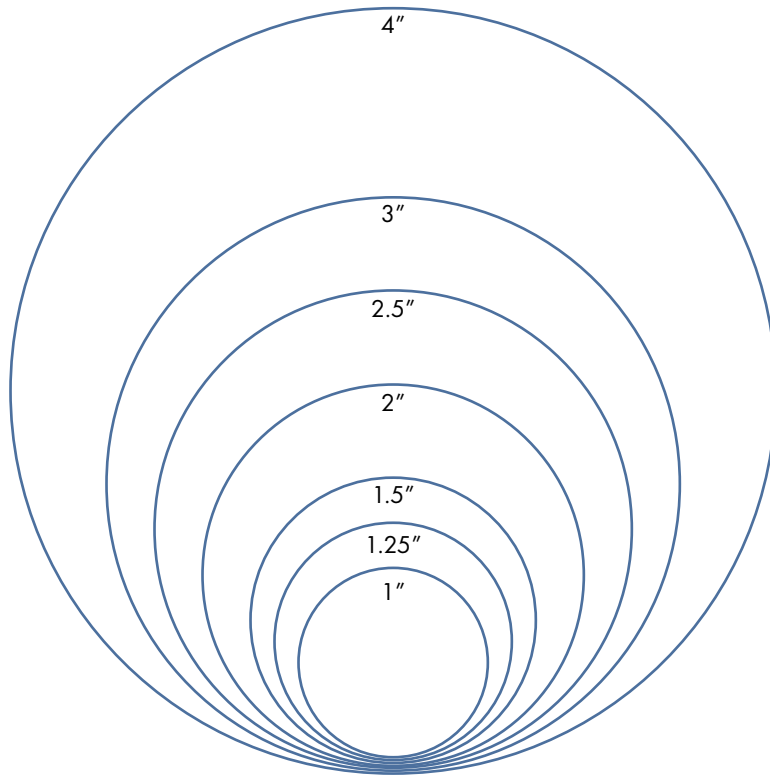

<b>2 WIRE DECODER SYSTEM</b>	Technology that permits control of large irrigation systems, over relatively long distances, by inserting waterproof decoder modules in a low voltage, direct burial two-wire path
<b>2 WIRE WATER WELL MOTOR</b>	Motor which has own relay and start capacitor built into the motor, which is suspended off the bottom of the pump in the well. The pump must be pulled out of the well to repair.
<b>ABSOLUTE PRESSURE</b>	Atmospheric pressure added to gauge pressure.
<b>ACCELERATION</b>	Rate at which velocity increases.
<b>ADAPTER</b>	Connects the dry (power) end to the wet end of a pump.
<b>AIR LOCK</b>	An air bubble caught in a pump or pipework that prevents the flow of water.
<b>ALIGNMENT</b>	Centerline of the pump is aligned to the drive shaft of a pump motor.
<b>AMBIENT COMPENSATED</b>	Environmental condition around an operating system where two elements (i.e. control and motor) are at different or changing temperatures.
<b>AMBIENT HEAT</b>	The heat that is present in and around the ground or water surface, primarily through the storage of solar energy
<b>AMBIENT PRESSURE</b>	The pressure of the surrounding air, gas or liquid in contact with an object at a specific location
<b>AMPERAGE</b>	Also known as current or Coulombs, it is the amount of electrical energy flowing through an appliance at any time, measured in amperes (amps).
<b>AMPERES (AMPS)</b>	Measurement of electrical energy flowing through an appliance.
<b>AMPHIBIOUS</b>	Equipment that can work on land and submerged in water.
<b>APPLICATION</b>	Conditions of use, in operation, that a pump must achieve to fulfill a specific outcome.
<b>ASME</b>	American Society of Mechanical Engineers.
<b>ATMOSPHERIC PRESSURE</b>	The pressure exerted by the weight of the atmosphere surrounding the earth – measured as pounds per square inch.
<b>AWWA</b>	American Water Works Association.
<b>ANSI PROCESS PUMP</b>	Horizontal, end suction, single stage pump with dimensionally standard sizes. Used in transfer and process applications for many type of industrial and manufacturing applications.
<b>API PROCESS PUMP</b>	Pump built to API 610 standard for use in industrial applications.
<b>AUGER PUMP</b>	Pump that raises water by means of helical impellers in the pump casing. Used in irrigation and dewatering applications.
<b>AXIAL FLOW PUMP</b>	Pump, also known as elbow or propeller pumps, that moves the fluid along the axis of the pump. They are used in high flow and low head applications.
<b>BACK FLOW</b>	Occurs when water flows in reverse of intended flow within the piping.
<b>BACK PLATE</b>	Pump component, also known as a bracket or mount ring, that attaches the motor and pump housing.
<b>BACK TO BACK DOUBLE SEAL</b>	Rotating seals are facing opposite directions.
<b>BACKFLOW PREVENTION DEVICE</b>	Used to prevent the flow of water from the system back to the pump/water source.
<b>BALL BEARING</b>	Friction reduction bearing device that uses both a rotating and stationary part separated by a ring of solid metal balls.
<b>BALL VALVE</b>	An adjustable valve that utilizes a spherical disk in order to control flow.
<b>BAR</b>	Metric term for an atmosphere of pressure.
<b>BASE PLATE</b>	Piece of material that the pump and motor is connected to.

<b>BASKET STRAINER</b>	A basket-shaped device that water flows through and into a pump – used to separate particulate and debris out of the fluid.
<b>BEARING</b>	Supports the rotating shaft and allows it to turn with minimal friction.
<b>BEARING - SEALED</b>	Designed bearing that requires little or no additional lubrication. See owner's manual.
<b>BEARING LUBRICATION</b>	Grease used to reduce friction, which allows for smooth continuous, operation of equipment, with only mild wear, and without excessive stress or seizure at the bearings.
<b>BEST EFFICIENCY POINT</b>	The point where the power coming out of the pump is closest to the power coming into the pump.
<b>BOOSTER PUMP</b>	A pump used to boost the existing pressure of a system.
<b>BOOSTER STATION</b>	A pumping system used to increase the pressure in a system.
<b>BUMP</b>	Momentarily supplying power to a pump to determine impeller rotation.
<b>BUTTERFLY VALVE</b>	Employing a metal disk, this valve can restrict flow or completely stop flow.
<b>CAM COUPLING (FITTING)</b>	Connection fitting which allows a quick hook-up and removal of hose at a pump or other connection point
<b>CANNED MOTOR PUMPS</b>	A sealless centrifugal pump, with an impeller that is attached to the motor rotor. Used in chemical or high temperature pump applications..
<b>CAPACITOR</b>	Storage device for electrical energy.
<b>CAPACITOR START MOTOR</b>	Motor in which a capacitor is in series with the start winding.
<b>CAPACITY (FLOW RATE)</b>	The amount of water a pump will put out or a tank will hold.
<b>CARBIDE</b>	A compound that is formed when carbon combines with an element creating a very hard metal often used as a mechanical seal face.
<b>CARBONIZING</b>	An effect that results in residue affecting the movement of mechanical seals.
<b>CASE-HOUSING</b>	The pump reservoir in which a fluid enters in the intake and then exits through the discharge.
<b>CAVITATE</b>	Occurs when a pump body's outgoing flow is not matched by the incoming flow. The imbalance creates molecules that release stored energy by imploding.
<b>CAVITATION DAMAGE</b>	The pitting or erosion of the impeller caused by the collapsing of any cavitation molecules.
<b>CENTRIFUGAL FORCE</b>	Fluid is forced from the center of the impeller outwards.
<b>CENTRIFUGAL PUMP</b>	A type of kinetic pump that employs centrifugal force to move water.
<b>CENTRIFUGAL SWITCH</b>	Within a motor, an electric switch that operates using centrifugal force created from a rotating shaft which disconnects the start windings after reaching operating speed.
<b>CERAMIC</b>	A hard, chemically inert seal face material.
<b>CHECK VALVE</b>	These valves only allow for a one way flow of liquid, entering at one end and exiting at the other.
<b>CHEMICAL FEEDER</b>	A device used to introduce chemicals into something else.
<b>CIRCUIT BREAKER</b>	An automatic device for stopping the flow of current in an electric circuit as a safety measure.
<b>CIRCULATOR PUMP</b>	Pump that is used in HVAC systems in buildings circulating all temperatures of water.
<b>CISTERN</b>	Waterproof receptacle for holding liquids.
<b>CLEAR WATER</b>	Rainwater runoff collected in a sump or collection basin.
<b>CLOSED IMPELLER</b>	These impellers are designed to have enclosed veins which increases the velocity of the liquid moving through the pump resulting in higher head.

<b>COMPOSITE</b>	A material made up of more than one substance.
<b>CONTINUOUS DUTY DESIGN</b>	A design specification that allows motors to run for long periods of time through heat disbursement.
<b>CONTROL BOX</b>	A device that contains electrical components and is used to control irrigation equipment.
<b>CONCRETE PUMP</b>	A concrete pump is designed to pump concrete and other mixed aggregate solutions.
<b>CORROSION RESISTANT</b>	Corrodes at a rate of .002 inches per year.
<b>CRYOGENIC PUMP</b>	Used in applications where the liquid is at a very low temperature.
<b>CURRENT</b>	The movement of an electrical charged matter, carried by electrons along a path (conductor, wire). Current is measured in terms of amperes (amps).
<b>CYCLING</b>	This happens when a pump repeatedly turns on and off, which can damage the pump.
<b>D.I.N. STANDARD</b>	The German standard for industrial products.
<b>DEAD HEAD</b>	The point on a pump performance curve where the unit is pumping zero GPM.
<b>DEEP WELL JET PUMP</b>	A pump that uses a two-pipe system and an ejector to increase suction lift.
<b>DEEP WELL SUBMERSIBLE PUMP</b>	Pumps that use stacked impellers to raise water to the surface. They can be submersed 1000' feet or more.
<b>DENSITY</b>	A measure of the weight of fluid.
<b>DEWATERING</b>	Removing water areas that you don't want water in.
<b>DIAPHRAGM PUMP</b>	Reciprocating positive displacement pump used where the fluid has high solids or high viscosity.
<b>DIFFUSER</b>	Component of a pump that directs the discharge flow of water coming off an impeller.
<b>DISCHARGE</b>	The pump outlet where water exits the pump.
<b>DISCHARGE HEAD</b>	The total head, including static head and friction head, on the discharge side of the pump.
<b>DISTANCE</b>	The straight line separation between an object and a reference point.
<b>DOUBLE SUCTION PUMP</b>	The rotor is suspended between bearings with the fluid entering on either side of the impeller. Used at higher capacities.
<b>DRAWDOWN</b>	The difference between the static water level and the pumping water level in a well.
<b>DRAWDOWN LEVEL</b>	The water level in a well, measured while the pump is running at full capacity.
<b>DRUM PUMP</b>	This slim pump is used to move small quantities of liquids out of drums and carboys.
<b>DRY END</b>	The motor end of the pump that never sees fluid.
<b>DRY RUNNING</b>	Running the pump without fluid at the seal face.
<b>DUAL SEAL</b>	Two seals running in various configurations.
<b>DUCTILITY</b>	The ability of a metal to be easily bent or stretched, rather than break.
<b>DYNAMIC (SYSTEM) HEAD</b>	The working load on a pump while it is running.
<b>DYNAMIC ELASTOMER</b>	The rubber part that has to move or flex to compensate for seal face wear or shaft movement.
<b>E.P.A.</b>	Environmental Protection Agency.
<b>E.P.R. (ETHYLENE PROPYLENE RUBBER)</b>	The most common elastomer used in the sealing of water based higher pH materials, but cannot be used in petroleum products.

<b>EFFECTIVE DIAMETER</b>	The calculated diameter where the pressure penetrates between the metal plates. This number is used to determine the hydraulic balance diameter of the seal face.
<b>EFFICIENCY</b>	Power out of the equipment divided by the power in.
<b>EFFLUENT</b>	Sewage or wastewater which has undergone some pretreatment.
<b>EFFLUENT PUMP</b>	A pump used in sanitary sump drainage and grey water applications. Usually pump smaller solids than a sewage pump.
<b>ELASTIC RANGE</b>	The stressed part retains its memory and returns to its original shape.
<b>ELASTOMER</b>	A rubber like material that, when compressed and then released will return 90% of its original shape in less than five seconds.
<b>ELECTRICAL DISCONNECT SWITCH (MOTOR NAMEPLATE REFERENCE)</b>	A manually operated external switch that is used to make sure that an electrical circuit can safely be completely de-energized.
<b>ELECTRICAL GROUND</b>	Circuits connected to the ground to protect the user.
<b>ELECTRICAL PHASE</b>	Motors are designed to run on either single or three phase power. Check the motor nameplate to determine. Consult power company for availability of power.
<b>ELECTRICAL RELAY</b>	An electrical switch that accepts a signal voltage from a source, allowing electricity to flow to a pump or other device.
<b>ELEVATION</b>	The vertical distance that a fluid must travel from the pump to the highest point in the discharge system.
<b>END SUCTION PUMP</b>	Flow enters the end of the casing and is pushed out of the top, used to transfer or circulate liquid. This is not a self priming pump and requires a foot valve.
<b>ENDURANCE LIMIT</b>	Beyond this point the metal will fatigue without increasing the stress.
<b>ENERGY DRIVEN PUMP</b>	A type of pump which uses an electric or hydraulic motor as its driver or motive force.
<b>EPDM (ETHYLENE PROPYLENE DIENE MONOMER)</b>	Elastomer characterized by a wide range of applications.
<b>EXTENDED DUTY DESIGN</b>	Designed for long-term intermittent use. (Not continuous duty use)
<b>EYE OF THE IMPELLER</b>	The center of the impeller, where the fluid enters.
<b>FACE LUBRICATION</b>	The fluid or vapor that sometimes exists between lapped mechanical seal faces.
<b>FACE PRESSURE</b>	The sum of all the loads on the seal face divided by the area of the seal face.
<b>FACE TO FACE SEALS</b>	Two seals running against a common seal face.
<b>FILTER</b>	A device used to remove solid particles from a fluid, removing smaller particles than a strainer.
<b>FIRE PUMP</b>	Centrifugal pump, employing high pressure, used for fire fighting.
<b>FLANGE</b>	A device used to couple to a pipe on the suction or discharge of a pump.
<b>FLEXIBLE IMPELLER PUMP</b>	Type of rotary displacement pump that has a rotating rubber impeller with vanes that bend then straighten as the impeller rotates to conform to the internal cam in the pump casing. Used in marine services.
<b>FLOAT CONTROL</b>	(see Float Switch)
<b>FLOAT SWITCH</b>	A hanging switch device used to detect the level of liquid within a tank.
<b>FLOW CONTROL VALVE</b>	A device that regulates the flow or pressure of a liquid.
<b>FLOW SLEEVE</b>	A sleeve attached to a submersible pump to force liquid to pass around it and enter the pump's suction intake from below to water cool the motor.

<b>FLOW SWITCH</b>	A device designed to monitor fluid flow in a pipe.
<b>FLUID</b>	A substance that can either be a liquid or a gas.
<b>FOOT VALVE</b>	Use to prevent debris from entering the pump or pipe and to prevent backflow. Assists with suction lift and reduces start-up stress on pump.
<b>FORCE</b>	An applied effort that tends to attempt to move something.
<b>FRANCIS VANE IMPELLER</b>	Most popular impeller shape with a specific speed between 1500 and 4000.
<b>FRICTION</b>	The resistance to motion of two objects or surfaces that touch.
<b>FRICTION LOSS</b>	The loss of pressure or head due to resistance to flow in the pipe and fittings.
<b>FRICTION LOSS CALCULATIONS</b>	Based on the type of pipe used, the size of the pipe, the average flow rate, and the length of the pipe.
<b>FRICTION LOSS CHARTS</b>	Table showing resistance to water movement within various types of piping material.
<b>FULL LOAD AMPS</b>	The amount of current a motor will draw at its rated horsepower.
<b>FULL PORT BALL VALVE</b>	A valve that allows for full pipe size flow, no friction loss, when in the open position.
<b>FUSE</b>	A safety device utilizing a thin strip of metal that will melt and break an electric current if the current exceeds a safe level.
<b>GALLONS PER DAY (GPD)</b>	Flow rate measurement.
<b>GALLONS PER HOUR (GPH)</b>	Flow rate measurement.
<b>GALLONS PER MINUTE (GPM)</b>	Flow rate measurement.
<b>GASKET</b>	A plastic or rubber ring or flat plastic or paper device used in machinery as a seal against air, oil, or high pressure.
<b>GATE VALVE</b>	This valve opens and closes by lifting or dropping a gate or wedge.
<b>GAUGE</b>	A measurement instrument, some uses include measuring PSI.
<b>GEAR PUMP</b>	Rotary displacement pump in which liquid is passed between two meshing gears and the surrounding casing. Used for clean oils and other viscous liquids.
<b>GLOBE VALVE</b>	A valve used to regulate flow in a pipeline, utilizing a movable disk.
<b>GOVERNOR</b>	A device that maintains a constant engine speed; a spring loaded device which is mounted under the canopy on the motor shaft designed to regulate rotational speed or momentum.
<b>GRAY WATER</b>	Non-toilet household wastewater that is sometimes recycled especially for use in gardening or for flushing toilets.
<b>GREASE SEAL (LIP SEAL)</b>	A spring loaded elastomer seal commonly used to seal bearing.
<b>GRINDER PUMP</b>	A sewage pump designed to chop or cut solids into smaller pieces.
<b>GROUND WATER</b>	The water that systems pump and treat from aquifers.
<b>H-O-A (HAND-OFF-AUTO)</b>	A toggle switch which allows you to choose how you want the pump to run. Auto allows flow switches to turn the pump on or off, while hand allows for manual on/off.
<b>HARD FACE</b>	A seal face either rotating or stationary, must be a wider seal face.
<b>HEAD IN FEET</b>	A term used to define water pressure in vertical feet.
<b>HERTZ (HZ)</b>	One cycle of AC electric flow.

<b>“HIGH VOLTAGE” (MOTOR NAMEPLATE REFERENCE)</b>	The highest voltage a motor can use to run. Running a motor on high voltage may increase the amperage draw and heat of the motor, while decreasing the life of the motor.
<b>HORSE POWER</b>	One horsepower is defined as the ability to move 33,000 pounds one foot in a minute. It is a measure of the work performed.
<b>HORIZONTAL SPLIT PUMP</b>	Centrifugal pumps that has a single double suction impeller supported between two bearings. Used in higher flow applications.
<b>HOSE CONNECTOR</b>	The fitting used to connect the hose to the wall or pump fitting.
<b>HYDRAULIC SHOCK</b>	A damaging condition that occurs when a column of liquid changes direction quickly and increases in velocity. Also known as water hammer.
<b>HYDRAULIC RAM PUMP</b>	Cyclic water pump power by hydropower, using the water hammer effect to develop pressure that allows a portion of the input water that powers the pump to be lifted to a point that is higher than where the water originally was. Used for pumping water to an elevation higher than the water source. Requires no outside source of power.
<b>I.S.O</b>	International standards organization. Sets and certifies manufacturing quality standards.
<b>IMPELLER</b>	Attaches to the end of the shaft to impart energy the fluid being pumped. Available in open, semi-open and closed designs.
<b>IMPELLER EYE</b>	The center of the impeller or where fluid enters the impeller.
<b>IMPELLER VANE</b>	Located between the eye and the discharge side of the impeller. Directs the flow of the liquid to the outside diameter of the impeller.
<b>IMPLODE</b>	Occurs when a material collapses in on itself, releasing stored energy in the molecules, causing damage to a pump. (Cavitation)
<b>INLET</b>	The entry point where water passes into a pump.
<b>JAMMED IMPELLER</b>	Occurs when some type of debris is pulled into the suction port that stops motor rotation.
<b>JET PUMP</b>	A centrifugal pump with a venturi attached, either at the pump (shallow well) or in the well (deep well).
<b>JOULE</b>	A metric unit for the measurement of heat. Defined as the energy required to move one Newton over one meter.
<b>KILOWATT</b>	One thousand watts. The normal unit for work in the metric system.
<b>LIFT</b>	The height that water must be pushed through a system.
<b>LIP SEAL (GREASE SEAL)</b>	A spring loaded elastomer seal commonly used to seal bearing.
<b>LIQUID LEVEL CONTROL</b>	General term given to any device that monitors the height change of liquid that can send a start/stop or warning signal to a separate electrical device.
<b>LIQUID LEVEL PROBES</b>	An electrical device that detects the level of liquid within a tank.
<b>LOBE PUMP</b>	Employs two shaft drive lobes which mesh with each other, but do not touch due to the use of timing gears. Used for food, beverage, pharmaceutical and biotech applications.
<b>LOW FLOW</b>	A condition that can cause excessive heat inside the pump volute.
<b>“LOW VOLTAGE” (MOTOR REFERENCE)</b>	Lowest voltage on which a motor will turn.
<b>LUBRICANT</b>	Any fluid that will maintain a film thickness of one micron or more at its operating temperature and load.
<b>MAGNETIC DRIVE PUMP</b>	A sealless centrifugal pump transmitting torque from the motor to the impeller using a rotating outer magnet which transmits the magnetic flux through a can to an inner magnet that is attached to the impeller. Used for pumping chemicals, hydrocarbons or other liquids difficult to seal.

<b>MECHANICAL GROOVE FITTING</b>	Components of a pipe joining system where a bolted coupling and gasket use grooves to join different parts together.
<b>MECHANICAL SEAL</b>	A positive sealing device used to seal all fluids.
<b>METERING PUMP</b>	Type of reciprocating positive displacement diaphragm pump that has a very low flow rate. Used to meter low doses with high accuracy, for chemical treatment applications.
<b>MINIMUM FLOW</b>	A condition where low fluid flow can cause excessive head inside the pump volute.
<b>MIXED FLOW PUMP</b>	Functions as a compromise between radial and axial flow pumps, the fluid experiences both radial acceleration and lift and exits the impeller somewhere between 0-90 degrees from the axial acceleration.
<b>MOTOR BEARINGS</b>	Supports both ends of the motor shaft allowing it to rotate smoothly with a minimum of friction and wear.
<b>MULTISTAGE PUMP</b>	A pump that utilizes multiple impellers, sometimes to boost pressure or increase the depth of a deep well pump.
<b>NET POSITIVE SUCTION HEAD (NPSH)</b>	NPSH compares the difference between the actual pressure of a liquid in a pipeline (available) and the point of cavitation in a pump (required).
<b>N.P.S.H.A</b>	Net Positive Suction Head Available is the amount of head available to overcome the NPSHR.
<b>N.P.S.H.R</b>	Net Positive Suction Head Required is the amount of head required by the pump to keep the liquid being pump in a liquid state.
<b>NBR (NITRILE RUBBER)</b>	Synthetic Rubber that is resistant to oil, fuel and other chemicals.
<b>NEC</b>	National Electrical Code is a standard for the safe installation of electrical wiring and equipment in the United States.
<b>NEMA</b>	National Electrical Manufacturers Association is the association of electrical equipment and medical imaging manufacturers in the United States.
<b>NEMA 1</b>	General-purpose electrical enclosure. Protects against dust, light and indirect splashing; primarily prevents contact with live parts. Used indoors and under normal atmospheric conditions.
<b>NEMA 3R</b>	Electrical enclosure intended for outdoor use. Mainly used in the irrigation industry to protect electrical components from falling rain and ice formation.
<b>NEMA 4</b>	Watertight (weatherproof) electrical enclosure used outdoors. Used for industrial applications; employing gaskets to protect against wind-driven or directed water, dust, or particle entry.
<b>NOZZLE</b>	A device attached to the end of a pipe or hose to direct the stream of liquid in a certain manner.
<b>O-RING GROOVE</b>	The space into which an O-ring is inserted.
<b>O.E.M</b>	Original equipment manufacturer.
<b>OHMS METER</b>	Device used to check the resistance of the flow of electricity.
<b>OIL LIFE</b>	Lubricating oil has a useful life of about thirty years at thirty degrees centigrade if it is not contaminated.
<b>OPEN IMPELLER</b>	Impellers designed with open blades or veins. This impeller works best when unrestricted.
<b>OSHA</b>	Occupation and Safety Health Administration is a federal agency of the United States that regulates workplace safety and health.
<b>OZONE</b>	An extremely oxidizing agent and bactericide, which consists of three oxygen atoms.

<b>PARALLEL OPERATION</b>	The pumps are discharging to a common header pipe.
<b>PERMEABLE</b>	Allowing some material to pass through.
<b>PERISTALTIC PUMPS</b>	Also known as a hose pump that has a roller or shoe that squeezes a tube or hose as it rotates. Used in applications where solids or corrosive liquids exist.
<b>pH</b>	A measurement of water acidity or alkalinity using a scale of 0-14. 7 is neutral, below 7 is acidic, above 7 is alkalinity.
<b>PIPE STRAIN</b>	The strain on the pump volute caused by the piping. It will cause excessive mechanical seal movement and can cause contact between rotating and stationary pump and seal components.
<b>PISTON PUMPS</b>	Pumps that employ double acting reciprocating pistons. Used in oil production and high pressure applications.
<b>PITTING</b>	Surface voids caused by corrosion, erosion or cavitation.
<b>PLUNGER PUMPS</b>	Pumps that are built with 3 or 5 single acting reciprocating plungers. Used in oil or high pressure applications.
<b>POLYMERS</b>	A chemical compound with many repeating structural units.
<b>POSITIVE DISPLACEMENT PUMP</b>	This pump does not have impellers, but instead relies on rotating or reciprocating parts that directly push liquid in an enclosed volume, until enough pressure is built up to move the liquid into the discharge system. Used in low flow, high pressure, high viscosity or fragile solid applications.
<b>POTABLE WATER</b>	Any water, such as an approved domestic water supply, which is bacteriologically safe and otherwise suitable for drinking.
<b>PRESSURE</b>	The effect produced by the application of force over the surface of an enclosed area.
<b>PRESSURE DROP</b>	The decrease of hydrostatic force due to the effects of friction or restrictions on a flowing liquid.
<b>PRESSURE GRADIENT</b>	The pressure drop between the seal faces.
<b>PRESSURE HEAD</b>	(see Static Head)
<b>PRESSURE SENSOR</b>	A device that measures the pressure of a gas or liquid.
<b>PRESSURE SWITCH</b>	Electrical/pneumatic device used to turn the pump on and off.
<b>PRIME</b>	Filling the pump case to remove any trapped air in the system.
<b>PROGRESSIVE CAVITY PUMP</b>	A type of positive displacement pump that transfers fluid by means of the progress, through the pump, of a sequence of small fixed shape, discrete cavities as the rotor is turned. Applications include: oil, slurry, and sewage pumping.
<b>PROPELLER</b>	A type of fan or impeller that converts energy into thrust.
<b>PSI</b>	Pounds per square inch.
<b>PUMP</b>	Converts mechanical energy into hydraulic energy.
<b>PUMP CURVE</b>	A diagram supplied by the pump manufacture to describe the relationship between the head and the capacity of a particular pump using various size impellers.
<b>PUMP EFFICIENCY</b>	The ratio of water power to the shaft power.
<b>PUMP HAT</b>	Small cover for protecting the pump motor from the elements while providing shade for cooling.
<b>PVC</b>	Polyvinyl Chloride. Plastic material widely used in irrigation for pipe and fittings because it is light, inexpensive, easy to assemble and can have a long life.
<b>RATE OF FLOW (GPM)</b>	The measurement of the volume of flow per unit of time expressed in gallons per minute.

<b>REDUCED EXTERNAL VOLTAGE - REV</b>	A wiring configuration ensuring any voltage leaving an electrical panel to a float, probe or other device is rated at a safe level of 30v.
<b>REDUCED INCOMING AMPS - RIA</b>	A component configuration that will work with low amperage incoming signals. Will work with all start/stop signal controls - including 2-wire systems.
<b>REGENERATIVE TURBINE PUMP</b>	Type of pump in which the fluid takes multiple trips through the vanes of the impeller increasing flow and pressure. Used in boiler feed applications.
<b>RELIEF VALVE</b>	A type of valved used to relieve the pressure in a system.
<b>RESISTANCE</b>	Impedes the flow of electrons, and is measured in Ohms
<b>ROTATION CLOCKWISE (cw)</b>	A left to right shaft rotation while facing the shaft end of a motor, or suction tap of a pump.
<b>ROTATION COUNTERCLOCKWISE (ccw)</b>	A right to left shaft rotation while facing the shaft end of a motor, or suction tap of a pump. Most pumps run this direction.
<b>ROLLER PUMP</b>	Employs rollers that revolve inside the pump housing to force a liquid through the outlet to the nozzle. Used for agricultural applications and industrial spraying.
<b>SAND PUMP</b>	A type of plunger pump that removes chopped-up drill core from a drill hole.
<b>SCREW PUMPS</b>	Built with two intermeshing screws, driven by timing gears these pumps are used in fuel transfer, and other applications requiring high flow rates of viscous liquids.
<b>S.F.A</b>	Service Factor Amps. A factor indicating the degree to which an electric motor can be operated over the specified horsepower without danger of overloading or failure.
<b>SEAL FACES</b>	The lapped faces that that provide the primary sealing in a mechanical seal.
<b>SEAL LIFE</b>	Seals should run leak free until the sacrificial face (usually carbon/ graphite) is worn away.
<b>SELF ALIGN</b>	A method of keeping both mechanical seal faces square to the rotating shaft.
<b>SELF PRIMING</b>	A pump with the ability to exhaust air/gas from a pump case.
<b>SELF PRIMING PUMP</b>	A centrifugal pump having the capability of dispersing a certain amount of air from its pump body, assuming the pump has been primed initially, when operating under a suction lift; to free itself of entrained gas without losing prime; and to continue normal pumping operation without attention.
<b>SEPTIC TANK</b>	A container used to collect wastewater from a house. Generally they have two compartments and are watertight. The larger compartment is for the raw sewage and the second compartment for effluent water. The second compartment can also be used as a pump chamber.
<b>SEWAGE</b>	Raw wastewater from residential, commercial or industrial sites. Sewage from residential sites is generally defined as 2" or less solids and commercial sites are 3" or 4" solids.
<b>SEWAGE PUMP</b>	A pump designed to pump black water (effluent).
<b>SHALLOW WELL</b>	A type of jet pump OR a well having less than 25' of lift.
<b>SHALLOW WELL SUBMERSIBLE PUMP</b>	A type of submersible pump will work up to a depth of around 100 feet.
<b>SHALLOW-WELL JET PUMP</b>	A type of pump that will work to a maximum depth of about 25 feet. The jet is either attached or pre-cast into the pump body.
<b>SHUT OFF HEAD</b>	The total head created by a pump that is running against a closed discharge.
<b>SILICA CARBIDE</b>	Synthetically produced crystalline compound that is incredibly hard - used in pump seals.
<b>SKIMMER</b>	A machine that separates debris from the top of the water.

<b>SLURRY</b>	Solids in liquid. It is impossible to define when the quantity and size of the particles becomes too much for the mechanical seal.
<b>SMARTBOX</b>	A Munro Manufacturing trademarked control panel that offers exceptional pump protection against loss of prime or heat.
<b>SOFT START</b>	Device used to temporarily reduce the load and torque in the powertrain and electrical current surge of the motor during startup.
<b>SOLENOID VALVE</b>	An automatic valve operating under low voltage (24V AC) which may be remotely located in the landscape and controlled via a signal cable from the central controller (timer).
<b>SOLUBLE</b>	When one liquid dissolves or mixes with another liquid.
<b>SPECIFIC GRAVITY</b>	Ratio of the weight of a volume of a substance to an equal volume of water.
<b>STAINLESS STEEL</b>	Alloy steels containing a high percentage of chromium.
<b>START SIGNAL</b>	An electrical signal sent to begin a water cycle. Signal can initiate from a switch, controller, manual operation or other means.
<b>STARTBOX</b>	A Munro Manufacturing trademarked control panel that provides pilot duty operation between start signal and pump.
<b>STATIC HEAD</b>	The maximum height that a liquid is being pump.
<b>STRAIN</b>	A measure of the amount of deformation produced in a substance when it is stressed.
<b>STRAINER</b>	Any device used to sift debris from inlet of pipework.
<b>STRESS</b>	A measure of the intensity of the load applied to a material.
<b>STRESS RELIEVE</b>	To take residual stress out of an object. This is very important with lapped seal faces; especially those that have been inserted into a metal holder.
<b>SUBMERSIBLE PUMP</b>	A multi-stage centrifugal pump with a waterproof electric motor mounted below the pump end.
<b>SUCTION HEAD</b>	The head on the suction side of the pump. You subtract it from the discharge head to determine the head being produced by the pump. It is a sum of the static, pressure and friction heads.
<b>SUCTION LEAK</b>	An escape of liquid from, or insertion of air into, the piping system going into a pump.
<b>SUCTION LIFT</b>	The condition where the water supply is below the pump.
<b>SUCTION SIDE (OF A PUMP)</b>	The side of the pump where the inlet is located.
<b>SUMP</b>	A low space that collect liquids such as water or chemicals.
<b>SYSTEM CAPACITY</b>	The ability of an irrigation system to deliver water to an acreage.
<b>SYSTEM CURVE</b>	A description of what the pump is required to perform. The pump will pump where the system curve intersects the pump curve.
<b>SYSTEM HEAD</b>	The head caused by friction in the piping, valves and fittings.
<b>T.D.H</b>	Total Discharge Head. A combination of the suction head and the head being produced by the pump.
<b>TANK</b>	A steel, plastic, or fibrewound vessel designed to store pressure or water.
<b>TEMPERATURE SWITCH</b>	A device used to monitor the temperature within a pump. If the temperature is too high the pump will turn off, protecting the pump.
<b>THERMAL CONDUCTIVITY</b>	A measure of the material's ability to conduct heat.

<b>THERMAL OVERLOAD</b>	Over-working equipment causing it to generate heat to the point of damaging itself.
<b>THERMAL OVERLOAD PROTECTION</b>	Relay used to shut down an overloaded motor before the motor becomes hot enough to cause damage. A bimetallic heat detection device.
<b>THERMAL PROTECTION</b>	A bimetallic heat detection device that will shut an overworked motor down before the generated heat causes damage to itself.
<b>THERMOPLASTIC</b>	A plastic material that can be softened or melted repeatedly without change of properties.
<b>TIME DELAY</b>	A adjustable timer capable of delaying an action after start signal is received.
<b>TORQUE</b>	A turning or twisting effort that results from a force being applied to a rigid object at a radial distance from the center of rotation.
<b>TORQUE ARRESTOR</b>	A device use to prevent the turning and twisting of pipes.
<b>TOTAL DYNAMIC HEAD (TDH)</b>	Total height that a fluid is to be pump, taking into account all losses, which include friction loss, pounds per square inch and elevation change.
<b>TRANSDUCER</b>	Attached to the pump and used to send a vibration signal to a meter where it can be read.
<b>TURBIDITY</b>	A measurement of the amount of suspended solids (colloids) in a solution.
<b>TRASH PUMP</b>	Self-priming centrifugal designed to handle rocks and other solids, used in dewatering applications.
<b>UTILITY PUMP</b>	An inexpensive pump similar to a sump pump except that it is not automatic.
<b>VANE IMPELLER (SEMI-OPEN)</b>	This has only one shroud. The other side of the impeller is in close contact with the pump volute case. The vanes of the impeller are spaced far enough apart to pass solids.
<b>VANE PASSING SYNDROME</b>	A type of cavitation caused by the impeller/ cutwater clearance being too small.
<b>VANE PUMPS</b>	These pumps employ a rotor with vanes located in slots, rotating inside an eccentrically shaped casing. Used in transferring oils and other viscous liquids.
<b>VAPORIZE</b>	The fluid passes from a liquid to a gaseous state. If this happens at the seal faces the seal faces will be blown open.
<b>VARIABLE FREQUENCY DRIVE</b>	Circuitry that runs a motor from 0 to 60 Hz. Adjusting the power to save energy.
<b>VARIABLE SPEED MOTOR</b>	Used to control flow in a system by varying the frequency of the motor. Recommended for circulating systems and any other system where the main head is friction losses in the piping system.
<b>VELOCITY</b>	The measurement of the motion of liquids, expressed in feet per second.
<b>VELOCITY HEAD</b>	Part of the total head calculation.
<b>VENT</b>	To remove air or gas from the system. It is important to vent the stuffing box in vertical pumps to prevent the seal faces from running dry.
<b>VERTICAL SUMP PUMP</b>	These pumps are built with a vertical shaft supported in a center column. Used in sump applications.
<b>VERTICAL TURBINE PUMP</b>	Vertical shaft pump that is designed to fit in a bore-hole well. Used for irrigation and booster applications.
<b>VISCOSITY</b>	Resistance to deformation by shear force. Example honey has a higher viscosity than water.
<b>VITON</b>	An E.I. Dupont Dow manufactured elastomer widely used in the sealing industry. The generic name is fluorocarbon. Many of these compounds are attacked by water and steam.
<b>VOC</b>	Volatile Organic Chemical. It is a category of water contaminants.

<b>VOLTAGE</b>	Electrical force or pressure that causes current to flow in a circuit.
<b>VOLTAGE IMBALANCE</b>	Difference between the highest and the lowest voltage exceeding 4%.
<b>VOLUTE CASING</b>	A pump component that encloses the impeller and converts the high velocity energy created by the impeller into pressure energy. It is spiral shaped, similar to a snail's shell.
<b>VORTEX IMPELLER</b>	This impeller creates a revolving mass of water which forms a whirlpool. Minimizing the risk of clogging.
<b>VORTEX PUMP</b>	A type of pump used for excessive solids. The impeller is recessed into the volute. A very low efficiency design, but practical in many applications.
<b>VORTEXING LIQUID</b>	Creating a "whirlpool affect" that can draw air into the suction of the pump.
<b>W.O.G</b>	Designation for parts rated for water, oil and gas.
<b>WATER HAMMER</b>	A damaging condition that occurs when a column of liquid changes direction quickly and increases in velocity. Also known as hydraulic shock.
<b>WATER HORSE POWER</b>	The energy added by the spinning impeller.
<b>WATER-COOLED</b>	Liquid is forced past the motor so that the heat of the motor can be transferred to the liquid increasing usage time and usable life.
<b>WATT</b>	A measurement of electrical power where watts = volts x amps. One watt is the rate of energy expended when a steady current of one amp flows under a pressure of one volt.
<b>WEAR RING</b>	Used with closed impeller pumps to restrict leakage from the high pressure side of the pump to the low pressure side. Should be replaced when the recommended clearance is doubled.
<b>WEEP HOLE - PUMP PANEL</b>	Small opening meant as an outlet for water to escape an electrical box.
<b>WEEP HOLE - PUMP</b>	Small opening meant as an outlet for air to escape a pump case to prevent air lock.
<b>WEIR</b>	A barrier that is designed to alter flow characteristics across rivers and streams.
<b>WELL CAP</b>	A tight-fitting, vermin-proof seal designed to prevent contaminants from flowing down inside of the well casing.
<b>WELL CASING</b>	The tubular lining of a well. Also a steel or plastic pipe installed during construction to prevent collapse of the well hole.
<b>WIRING DIAGRAM</b>	Shows how the pump is wired for voltage.
<b>Y-STRAINER</b>	Inline strainer that removes unwanted solids from liquid, gas, or steam lines.
<b>ZONE</b>	A zone is the area to be watered by a single control valve. Zones are ideally comprised of similar sprinkler types and plants with similar water requirements. This term is usually used with domestic sprinkler systems.

<b>ANSI Process Pump</b>	Horizontal, end suction, single stage pump with dimensionally standard sizes. Used in transfer and process applications for many types of industrial and manufacturing applications.
<b>API Process Pump</b>	Pump built to API 610 standard for use in industrial applications.
<b>Auger Pump</b>	Pump that raises water by means of helical impellers in the pump casing. Used in irrigation and dewatering applications.
<b>Axial Flow Pump</b>	Also known as propeller pump, pump that is very high flow, low head. Used in dewatering, circulating and irrigation applications.
<b>Booster Pump</b>	This pump is used to boost the pressure in a system.
<b>Canned Motor Pumps</b>	A seal-less centrifugal pump, with an impeller that is attached to the motor rotor. Used in chemical or high temperature pump applications. Can be flooded rotor or magnetic drive.
<b>Circulator Pump</b>	Pump that is used in HVAC systems in buildings circulating all temperatures of water.
<b>Concrete Pump</b>	A concrete pump is designed to pump concrete and other mixed aggregate solutions.
<b>Cryogenic Pump</b>	Used in applications where the liquid is at a very low temperature.
<b>Deep Well Jet Pump</b>	Uses a venturi, which becomes a second pump that charges the above ground unit, to increase pressure.
<b>Deep Well Submersible Pump</b>	Pump that can be submersed 1000's of feet.
<b>Diaphragm Pump</b>	Reciprocating positive displacement pump used where the fluid has high solids or high viscosity. Works with two valves like a human heart.
<b>Double Suction Pump (horizontal split case)</b>	The rotor is suspended between bearings with the fluid entering on either side of the impeller.
<b>Drum Pump</b>	This slim pump is used to move small quantities of liquids out of drums and carboys.
<b>Effluent Pump</b>	A pump used in sanitary sump drainage and grey water applications. Usually pumps smaller solids than a sewage pump.
<b>End Suction Pump</b>	Flow enters the end of the casing and is pushed out of the top, used to transfer or circulate liquid. This is not a self-priming pump and requires a foot valve.
<b>Fire Pump</b>	Centrifugal pump, employing high pressure, used for fire fighting.

<b>Flexible Impeller Pump</b>	Type of rotary displacement pump that has a rotating rubber impeller with vanes that bend then straighten as the impeller rotates to conform to the internal cam in the pump casing. Used in marine services.
<b>Gear Pump</b>	Positive displacement pump in which liquid is passed between two meshing gears and the surrounding casing. Used for clean oils and other viscous liquids.
<b>Grinder Pump</b>	A sewage pump designed to chop or cut solids into smaller pieces.
<b>Horizontal Split Pump</b>	Centrifugal pump that has a single, double suction impeller supported between two bearings. Used in higher flow applications.
<b>Hydraulic Ram Pump</b>	Cyclic water pump powered by hydro power, using the water hammer effect to develop pressure that allows a portion of the input water that powers the pump to be lifted to a point that is higher than where the water originally was. Used for pumping water to an elevation higher than the water source. Requires no outside source of power.
<b>Jet Pump</b>	A centrifugal pump with a venturi attached, either at the pump (shallow well) or in the well (deep well).
<b>Lobe Pump</b>	Employs two shaft drive lobes which mesh with each other but do not touch, due to the use of timing gears. Used for food, beverage, pharmaceutical and biotech applications.
<b>Magnetic Drive Pump</b>	A seal-less centrifugal pump transmitting torque from the motor to the impeller using a rotating outer magnet which transmits the magnetic flux through a can to an inner magnet that is attached to the impeller. Used for pumping chemicals, hydrocarbons or other liquids difficult to seal.
<b>Metering pump</b>	Type of reciprocating positive displacement diaphragm pump that has a very low flow rate. Used to meter low doses with high accuracy, for chemical treatment applications.
<b>Mixed Flow Pump</b>	Functions as a compromise between radial and axial flow pumps, the fluid experiences both radial acceleration and lift and exits the impeller somewhere between 0-90 degrees from the axial acceleration.
<b>Multistage Pump</b>	A pump that utilizes multiple impellers, sometimes to boost pressure or increase the depth of a deep well pump.
<b>Peristaltic Pumps</b>	Also known as a hose pump that has a roller or shoe that squeezes a tube or hose as it rotates. Used in applications where solids or corrosive liquids exist.
<b>Piston Pumps</b>	Pumps that employ double acting reciprocating pistons. Used in oil production and high pressure applications. Utilizes some type of sliding scale.
<b>Plunger Pumps</b>	Pumps that are built with 3 or 5 single acting reciprocating plungers. Used in oil or high pressure applications. Works on close tolerance.

<b>Positive Displacement Pump</b>	This pump does not have impellers, but instead relies on rotating or reciprocating parts that directly push liquid in an enclosed volume, until enough pressure is built up to move the liquid into the discharge system. Used in low flow, high pressure, high viscosity or fragile solid applications.
<b>Progressive Cavity Pump</b>	A type of positive displacement pump that transfers fluid by means of the progress, through the pump, of a sequence of small fixed shape, discrete cavities as the rotor is turned. Applications include: oil, slurry, and sewage pumping.
<b>Regenerative Turbine Pump</b>	Type of pump in which the fluid takes multiple trips through the vanes of the impeller increasing flow and pressure. Used in boiler feed applications.
<b>Roller Pump</b>	Employs rollers that revolve utilizing centrifugal force inside the pump housing to force a liquid through the outlet to the nozzle. Used for agricultural applications and industrial spraying.
<b>Sand Pump (Plunger Sand Centrifugal)</b>	A type of plunger pump that removes chopped-up drill core from a drill hole.
<b>Screw Pumps (Gear, Auger) (See Auger)</b>	Built with two inter-meshing screws, driven by timing gears, these pumps are used in fuel transfer, and other applications requiring high flow rates of viscous liquids. See Auger.
<b>Self-Priming Pump</b>	A centrifugal pump having the capability of dispersing a certain amount of air from its pump body, assuming the pump has been primed initially, when operating under a suction lift; to free itself of entrained gas without losing prime and to continue normal pumping operation without attention.
<b>Sewage Pump</b>	A pump designed to pump raw sewage water.
<b>Shallow-Well Jet Pump</b>	A type of pump that will work to a maximum depth of about 25 feet. The water returns through a venturi orifice and is either attached or pre-cast into the pump body to assist with lift. See Jet Pump.
<b>Single-stage Submersible Pump</b>	A submersible pump with only one impeller.
<b>Slurry Pump</b>	A pump that handles abrasive slurry in mining, procession, dredging and slurry applications.
<b>Spur-gear Pump (Internal Gear)</b>	Utilizing a "gear within a gear" system, the inter-meshing gear provides pockets of liquid which rotate and force liquid from the pump. Used in industrial applications to pump fluids such as fuel, glycol and asphalt.
<b>Submersible Pump</b>	Pumps with an enclosed motor that are able to be submersed. Used in sump, dewatering and irrigation applications.
<b>Trash Pump</b>	Self-priming centrifugal designed to handle rocks and other solids, used in dewatering applications.
<b>Utility Pump</b>	A versatile submersible pump similar to a sump pump.

<b>Vane Pumps</b>	These pumps employ a rotor with vanes located in slots, rotating inside an eccentrically shaped casing. Used in transferring oils and other viscous liquids.
<b>Vertical Sump Pump</b>	These pumps are built with a vertical shaft supported in a center column to allow the motor to run above the pumped product. Used in sump applications.
<b>Vertical Turbine Pump</b>	Vertical shaft pump that is designed to fit in a bore-hole well or for short coupled units, rivers or ponds. Used for irrigation and booster applications.
<b>Vortex Pump</b>	A type of pump used for excessive solids. The impeller is recessed into the volute and pumps by creating a vortex within the chamber.

## Associations/Organizations

<b>ANSI</b>	American National Standards Institute	<a href="http://www.ansi.org">www.ansi.org</a>
<b>API</b>	American Petroleum Institute	<a href="http://www.api.org">www.api.org</a>
<b>ARCOSA</b>	American Rainwater Catchment Systems Association	<a href="http://www.arcosa.org">www.arcosa.org</a>
<b>ASIC</b>	American Society of Irrigation Consultants	<a href="http://www.asic.org">www.asic.org</a>
<b>ASLA</b>	American Society of Landscape Architects	<a href="http://www.asla.org">www.asla.org</a>
<b>ASME</b>	American Society of Mechanical Engineers	<a href="http://www.asme.org">www.asme.org</a>
<b>AWWA</b>	American Water Works Association	<a href="http://www.awwa.org">www.awwa.org</a>
<b>CE</b>	Consumer Electronics Association	<a href="http://www.ce.org">www.ce.org</a>
<b>CSA</b>	Canadian Standards Association	<a href="http://www.csagroup.org">www.csagroup.org</a>
<b>D.I.N. Standard</b>	Deutsches Institut für Normung	<a href="http://www.din.de/en">www.din.de/en</a>
<b>EPA</b>	Environmental Protection Agency	<a href="http://www.epa.gov">www.epa.gov</a>
<b>EASA</b>	Electrical Apparatus Service Association	<a href="http://www.easa.com">www.easa.com</a>
<b>FM</b>	Industrial and Commercial Product Certification	<a href="http://www.fmglobal.com">www.fmglobal.com</a>
<b>IA</b>	Irrigation Association	<a href="http://www.irrigation.org">www.irrigation.org</a>
<b>ISO</b>	International Standards Organization	<a href="http://www.iso.org">www.iso.org</a>
<b>NAHAD</b>	National Association for Hose and Accessory Distributors	<a href="http://www.nahad.org">www.nahad.org</a>
<b>NEC</b>	National Electric Code	<a href="http://www.nec.com">www.nec.com</a>
<b>NEMA</b>	National Electrical Manufacturers Association	<a href="http://www.nema.org">www.nema.org</a>
<b>OSHA</b>	Occupational Safety and Health Administration	<a href="http://www.osha.gov">www.osha.gov</a>
<b>UL</b>	Underwriter's Laboratories	<a href="http://www.ul.com">www.ul.com</a>

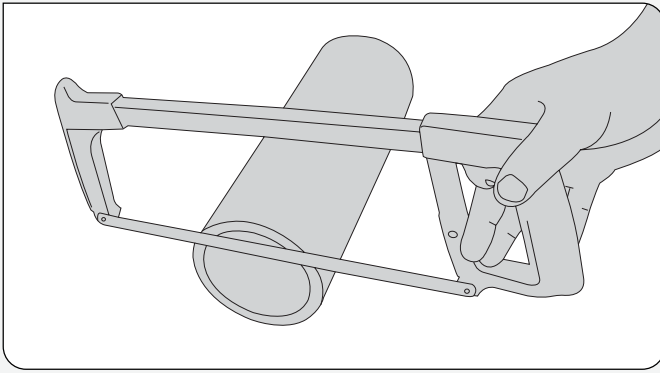

## 1. CUT THE PIPE

Make certain that the pipes are cut squarely and free of imperfections.

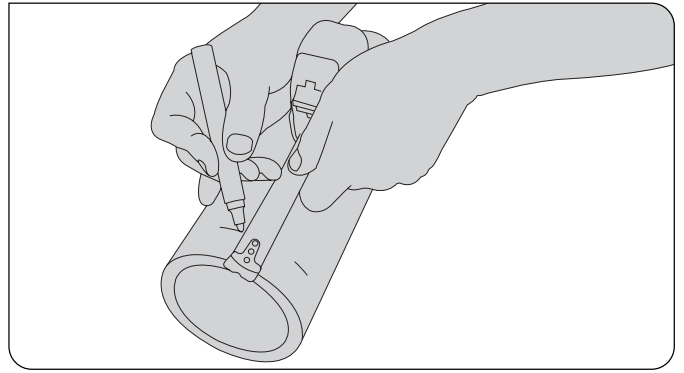

## 2. MEASURE FOR GASKET PLACEMENT

Measure and mark a minimum of 4 equally spaced lines around each of the pipes you will join. These lines will mark where the edge of the gasket should be, to ensure that the gasket is centered between the 2 pipes.

- 2" thru 4" pipe - mark  $7/8$ " from the end of the pipe
- 6" pipe - mark 1" from the end of the pipe
- 8" thru 12" pipe - mark  $1\ 1/16$ " from the end of the pipe

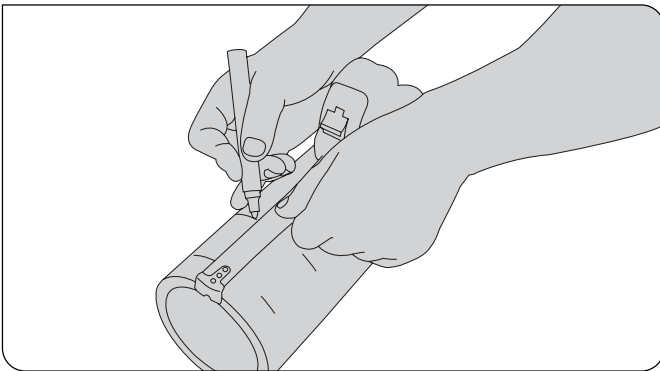

## 3. MEASURE FOR COUPLING PLACEMENT

Measure and mark another set of a minimum of 4 equally spaced lines around each of the pipes you will join. These lines will mark where the edge of the fitting should be, to ensure that the pipe placement is correct when the coupling is installed.

- 2" thru 4" pipe - mark  $2\ 5/16$ " from the end of the pipe
- 4" thru 6" pipe - mark 3" from the end of the pipe
- 8" pipe - mark  $3\ 1/16$ " from the end of the pipe
- 10" pipe - mark  $3\ 1/4$ " from the end of the pipe
- 12" pipe - mark  $3\ 9/16$ " from the end of the pipe

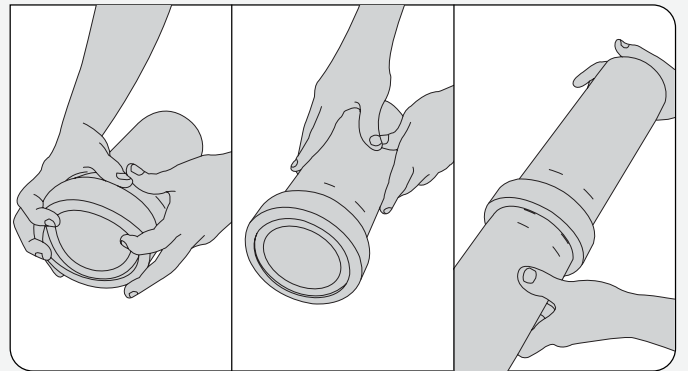

## 4. INSTALL GASKET

Ensure that the gasket is free from burrs or any imperfections and that the gasket material and size is acceptable for the intended service. Slide the gasket over the pipe end so that it is flush with the pipe end. Next, butt up against and center with the other pipe. Slide the gasket into place, so that it is equally covering both pieces of pipe. Use the first set of lines that you marked on the pipe as a guide to ensure proper placement, centering the gasket between the pipes.

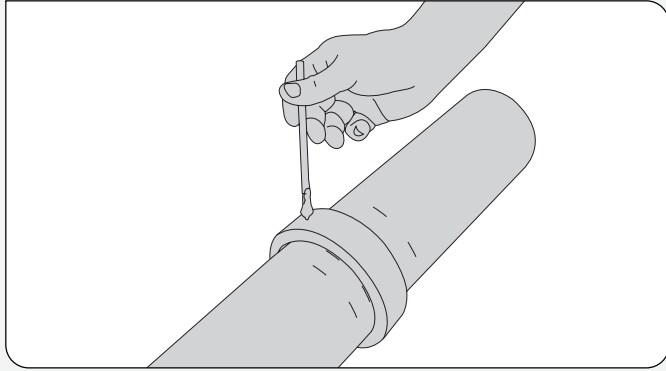

## 5. PREPARE GASKET

Apply a thin coating of lubricant on the exterior and lip of the gasket. We recommend only silicon based lubricant for our Nitrile gaskets. Please check with the pipe manufacturer to ensure that your chosen lubricant is compatible with the pipe.

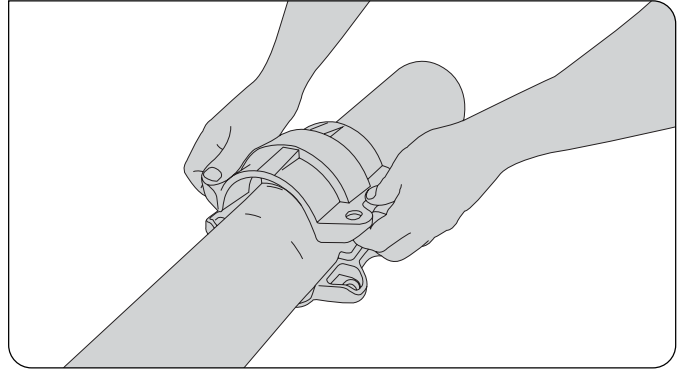

## 6. INSTALL HOUSINGS

Place the coupling halves over the gasket. Ensure that the two halves mate correctly, that the gasket stays centered on the pipe and that the pipes remain butted together. Use the lines that you marked on the pipe as a guide to ensure proper placement.

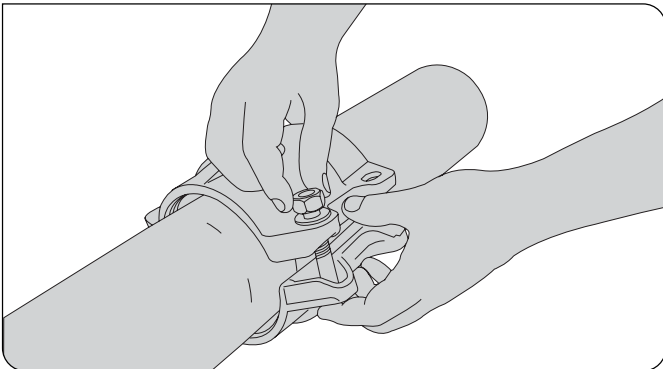

## 7. INSTALL BOLTS

Either a flanged nut or a nut and a washer are provided. Add washers (if provided) and hand tighten nuts.

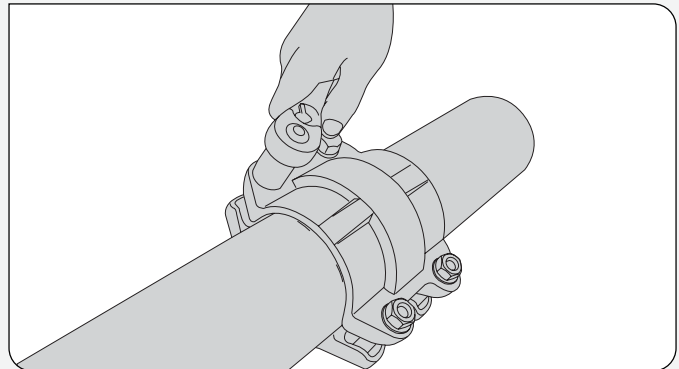

## 8. TIGHTEN NUTS

When metal to metal contact is achieved, bolt torque should fall within specified range.

### SPECIFIED BOLT TORQUE

Specified bolt torque is for the oval neck track bolts used on Munro couplings. The nuts must be tightened alternately and evenly until fully tightened. CAUTION: Use of an impact wrench is not recommended because the torque output can vary significantly due to many variables including air pressure supply, battery strength and operational variations.

#### ⚠ CAUTION

Proper torquing of coupling bolts is required to obtain specified performance. Over torquing the bolts may result in damage to the bolt and/or casting which could result in pipe joint separation. Under torquing the bolts may result in lower pressure retention capabilities, lower bend load capabilities, joint leakage and pipe joint separation. Pipe joint separation may result in significant property damage and serious injury.

### BOLT TORQUE

Coupling Bolts	Minimum		Maximum	
	In.	Ft.-Lbs./N-m	Ft.-Lbs./N-m	Ft.-Lbs./N-m
1/2 X 2 3/8 (2" couplings)		80 110		100 150
1/2 X 3 (3"- 4" couplings)		80 110		100 150
5/8 X 3 1/2 (6"- 8" couplings)		100 135		130 175
3/4 X 4 3/4 (10"- 12" couplings)		130 175		180 245

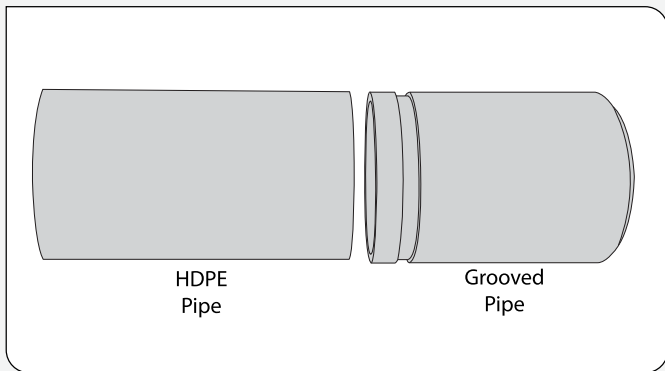

## 1. INSPECT PIPES ENDS

Inspect the steel grooved pipe. Make certain that any burrs, grease, dirt or foreign objects are removed from the grooved end. Ends must be free of sharp edges, indentations, or other defects.

Inspect the HDPE pipe. Make certain that the pipes are cut squarely and free of imperfections.

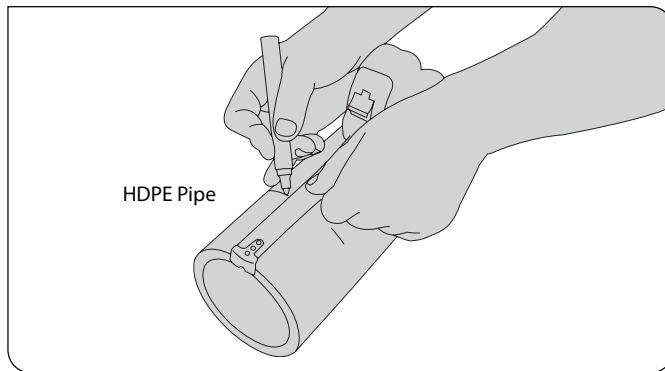

## 2. MEASURE FOR COUPLING PLACEMENT

Measure and mark, at a minimum, 5 equally spaced lines around the HDPE pipe to ensure that the pipe placement is correct when the coupling is installed.

- 2" thru 3" pipe - mark 2 1/8" from the end of the pipe
- 4" thru 6" pipe - mark 2 3/4" from the end of the pipe
- 8" pipe - mark 3" from the end of the pipe
- 10" pipe - mark 3 3/4" from the end of the pipe
- 12" pipe - mark 3 7/8" from the end of the pipe

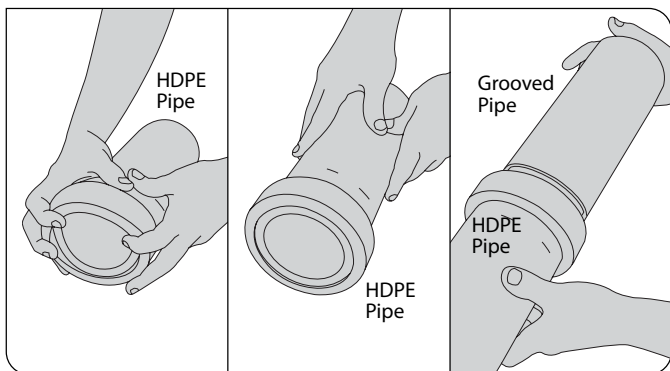

## 3. INSTALL GASKET

Inspect gasket to ensure that it is the correct material for the application and that it is clean and free of defects.

Slide the gasket over the end of the HDPE pipe until the gasket is not overhanging the end of the pipe. Next, align the HDPE pipe end with the grooved steel pipe end and slide the gasket into place so that it is centered between the two pipe ends. The gasket should not extend into the groove on the steel pipe.

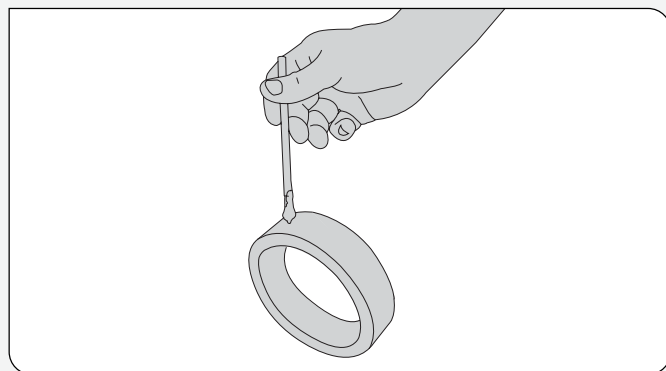

## 4. LUBRICATE GASKET

Coat the sealing edges and outer surface of the gasket with a thin layer of silicon-based lubricant (available from Munro).

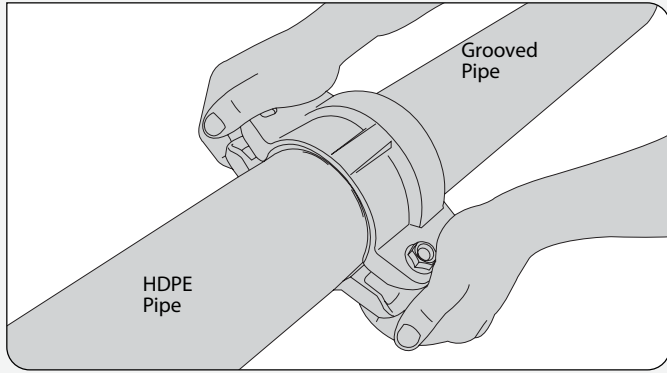

## 5. INSTALL HOUSINGS AND BOLTS

Align housings over the gasket. Your marks on the HDPE pipe should align with the edge of the housing. You may find it easier to start with one bolt in place, with the nut unthreaded to the end of the bolt. Insert the bolts through the housings and thread the nuts on the bolts until they are finger tight. Ensure that the housings are not misaligned and that the oval head of each bolt sits properly in the bolt hole.

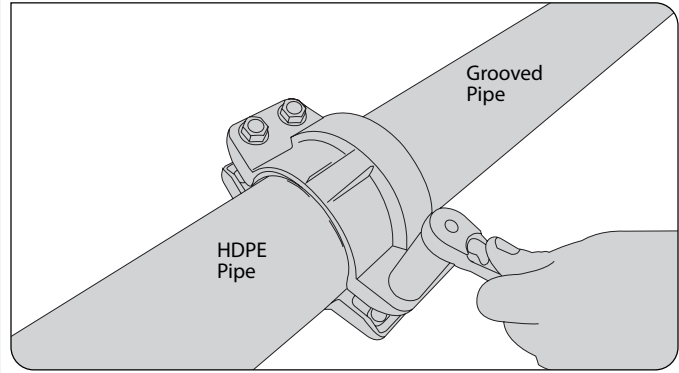

## 6. TIGHTEN NUTS

Using the torque specification table as a guide, ensure that the nuts are tightened alternately and equally until metal to metal contact is made with no gaps.

### SPECIFIED BOLT TORQUE

Specified bolt torque is for the oval neck track bolts used on Munro couplings. The nuts must be tightened alternately and evenly until fully tightened. CAUTION: Use of an impact wrench is not recommended because the torque output can vary significantly due to many variables including air pressure supply, battery strength and operational variations.

#### ⚠ CAUTION

Proper torquing of coupling bolts is required to obtain specified performance. Over torquing the bolts may result in damage to the bolt and/or casting which could result in pipe joint separation. Under torquing the bolts may result in lower pressure retention capabilities, lower bend load capabilities, joint leakage and pipe joint separation. Pipe joint separation may result in significant property damage and serious injury.

### BOLT TORQUE

Coupling Bolts	Minimum		Maximum	
	In.	Ft.-Lbs./N-m	Ft.-Lbs./N-m	Ft.-Lbs./N-m
1/2 X 2 3/8 (2" couplings)		80 110		100 150
1/2 X 3 (3" - 4" couplings)		80 110		100 150
5/8 X 3 1/2 (6" - 8" couplings)		100 135		130 175
3/4 X 4 3/4 (10" - 12" couplings)		130 175		180 245

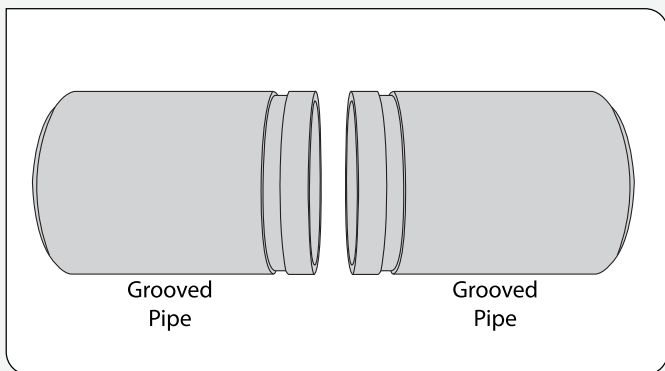

## 1. INSPECT GROOVED END PIPES OR FITTINGS

Make certain that any burrs, grease, dirt or foreign objects are removed from the grooved end. Ends must be free of sharp edges, indentations, or other defects.

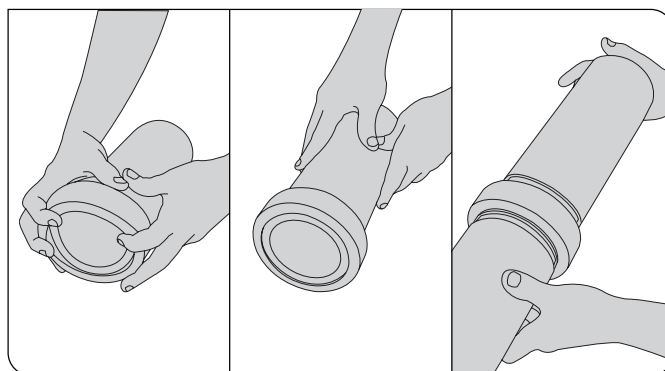

## 2. INSTALL GASKET

Inspect gasket to ensure that it is the correct material for the application and that it is clean and free of defects.

Slide the gasket over the end of the pipe until the gasket is not overhanging the end of the pipe. Next, align the two pipe ends and slide the gasket into place so that it is centered between the two pipe ends, between the groove on either pipe.

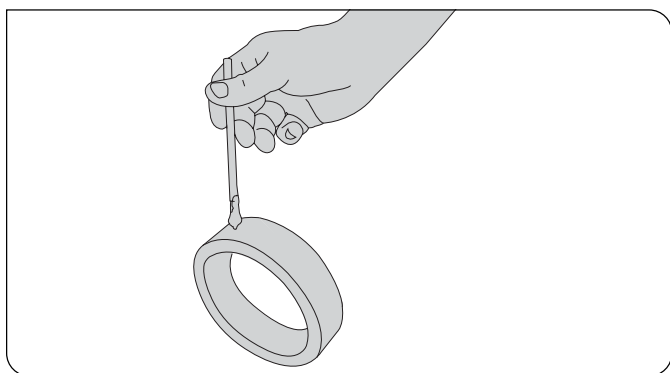

## 3. LUBRICATE GASKET

Coat the sealing edges and outer surface of the gasket with a thin layer of silicon-based lubricant (available from Munro).

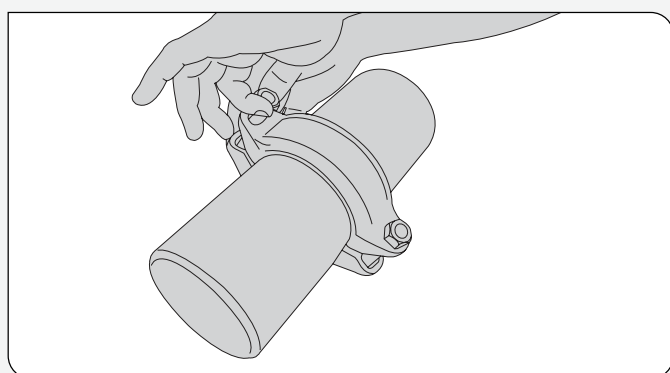

## 4. INSTALL HOUSINGS AND BOLTS

Ensure that the grooved ends remain aligned and together. Align the housings over the gasket. Ensure that the housing's grooved end is inserted into the pipe's groove. Insert the bolts through the housings and thread the nuts on the bolts until they are finger tight. Ensure that the housings are not misaligned and that the oval head of each bolt sits properly in the bolt hole.

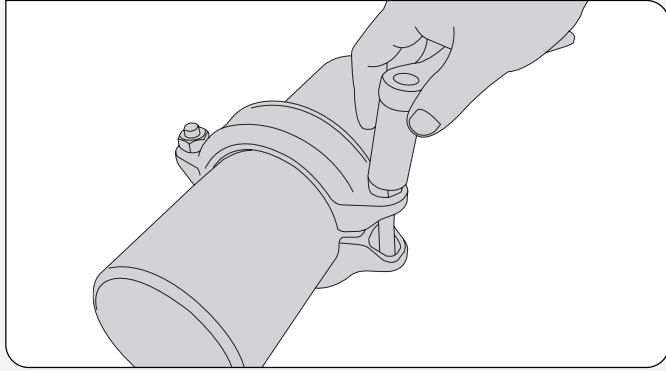

## 5. TIGHTEN NUTS

Using the torque specification table as a guide, ensure that the nuts are tightened alternately and equally until metal to metal contact is made with no gaps.

## SPECIFIED BOLT TORQUE

Specified bolt torque is for the oval neck track bolts used on Munro couplings. The nuts must be tightened alternately and evenly until fully tightened. CAUTION: Use of an impact wrench is not recommended because the torque output can vary significantly due to many variables including air pressure supply, battery strength and operational variations.

### ⚠ CAUTION

Proper torquing of coupling bolts is required to obtain specified performance. Over torquing the bolts may result in damage to the bolt and/or casting which could result in pipe joint separation. Under torquing the bolts may result in lower pressure retention capabilities, lower bend load capabilities, joint leakage and pipe joint separation. Pipe joint separation may result in significant property damage and serious injury.

## BOLT TORQUE

Coupling Bolts	BOLT TORQUE	
	Minimum	Maximum
In.	Ft.-Lbs./N-m	Ft.-Lbs./N-m
1/2 X 2 3/8 (2" couplings)	80 110	100 150
1/2 X 3 (3" - 4" couplings)	80 110	100 150
5/8 X 3 1/2 (6" - 8" couplings)	100 135	130 175
3/4 X 4 3/4 (10" - 12" couplings)	130 175	180 245

## Standard Cut Groove for Steel and Other IPS Pipe

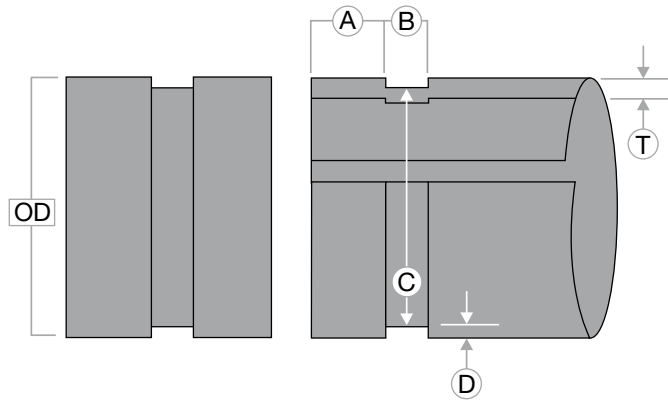

Nom- inal Size	Pipe OD						A		B		D		C				T	
	Basic		Tolerance				Gasket Seat ± 0.03 in ± 0.77 mm		Groove Width ± 0.03 in ± 0.77 mm		Groove Depth (Reference)		Groove Diameter		Min. Pipe Wall Thickness			
	in	in/mm	+	-	+	-	in/mm	in/mm	in/mm	in/mm	in/mm	in/mm	Actual	Tolerance + 0.00	in/mm	in/mm		
1	1.32	33.7	0.01	0.33	-0.01	-0.33	0.62	15.88	0.31	7.93	0.06	1.70	1.19	30.23	-0.01	-0.38	0.12	3.3
1 1/4	1.66	42.4	0.01	0.41	-0.01	-0.41	0.62	15.88	0.31	7.93	0.06	1.70	1.53	38.99	-0.01	-0.38	0.13	3.5
1 1/2	1.90	48.3	0.01	0.48	-0.01	-0.48	0.62	15.88	0.31	7.93	0.07	1.98	1.77	45.09	-0.01	-0.38	0.14	3.6
2	2.37	60.3	0.02	0.61	-0.02	-0.61	0.62	15.88	0.31	7.93	0.07	1.98	2.25	57.15	-0.01	-0.38	0.14	3.6
2 1/2	2.87	73.0	0.02	0.74	-0.02	-0.74	0.62	15.88	0.31	7.93	0.07	1.98	2.72	69.09	-0.01	-0.46	0.15	4.0
3	3.50	88.9	0.03	0.89	-0.03	-0.79	0.62	15.88	0.31	7.93	0.07	1.98	3.34	84.94	-0.01	-0.46	0.17	4.5
3 1/2	4.00	101.6	0.04	1.02	-0.03	-0.79	0.62	15.88	0.31	7.93	0.08	2.11	3.83	97.38	-0.02	-0.51	0.19	5.0
4	4.48	114.0	0.04	1.14	-0.03	-0.79	0.62	15.88	0.37	9.53	0.08	2.11	4.33	110.08	-0.02	-0.51	0.19	5.0
5	5.56	141.3	0.05	1.42	-0.03	-0.79	0.62	15.88	0.37	9.53	0.08	2.13	5.39	137.03	-0.02	-0.51	0.19	5.0
6	6.62	168.3	0.06	1.60	-0.03	-0.79	0.62	15.88	0.37	9.53	0.08	2.16	6.45	163.96	-0.02	-0.56	0.21	5.4
8	8.62	219.1	0.06	1.60	-0.03	-0.79	0.75	19.05	0.43	11.10	0.09	2.34	8.44	214.40	-0.02	-0.64	0.21	5.4
10	10.74	273.0	0.06	1.60	-0.03	-0.79	0.75	19.05	0.50	12.70	0.09	2.39	10.56	268.28	-0.02	-0.69	0.24	6.3
12	12.75	323.9	0.06	1.60	-0.03	-0.79	0.75	19.05	0.50	12.70	0.10	2.77	12.53	318.29	-0.02	-0.76	0.27	7.1

<b>"A" Dimension</b>	The distance from the pipe end to the groove, identifies the gasket seating area. This area must be free from indentations, projections (including weld seams), and roll marks from the pipe end to the groove to ensure a leak-tight seal for the gasket. All foreign material, such as loose paint, scale, oil, grease, chips, rust, and dirt must be removed.
<b>"B" Dimension</b>	The groove width, controls expansion, contraction, and angular deflection of flexible couplings by the distance it is located from the pipe and its width in relation to the coupling housings' "key" width. The bottom of the groove must be free of all foreign material, such as dirt, chips, rust, and scale that may interfere with proper coupling assembly.
<b>"C" Dimension</b>	The proper diameter at the base of the groove. This dimension must be within the diameter's tolerance and concentric with the outer diameter (OD) for proper coupling fit. The groove must be of uniform depth for the entire pipe circumference.
<b>"D" Dimension</b>	The normal depth of the groove, a reference for a "trial groove" only. Variations in pipe OD affect this dimension and must be altered, if necessary, to keep the "C" dimension within tolerance. This groove must conform to the "C" dimension described above.
<b>"T" Dimension</b>	The lightest grade (minimum, nominal wall thickness) of pipe that is suitable for cut or roll grooving.

Munro grooved fittings are made to USA standards and adhere to AWWA C-606 groove dimensions.

## Standard Roll Groove for Steel and Other IPS Pipe

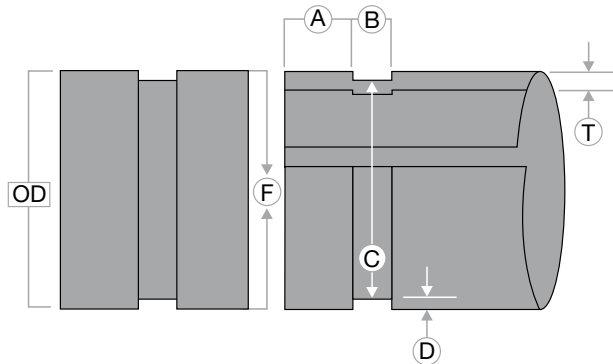

Nominal Size	Pipe OD						A		B		D		C		T		F			
	Basic		Tolerance				Gasket Seat		Groove Width		Groove Depth		Groove Diameter		Min. Pipe Wall Thickness		Reference			
	in	in/mm	+	-	+	-	± 0.03 in ± 0.77 mm	± 0.03 in ± 0.77 mm	± 0.03 in ± 0.77 mm	(Reference)	Actual	Tolerance + 0.00	in/mm	in/mm	in/mm	in/mm	in/mm	in/mm		
1	1.32	33.7	0.01	0.33	-0.01	-0.33	0.62	15.88	0.28	7.14	0.06	1.60	1.19	30.23	-0.01	-0.38	0.07	1.8	1.35	34.5
1 1/4	1.66	42.4	0.01	0.41	-0.01	-0.41	0.62	15.88	0.28	7.14	0.06	1.60	1.53	38.99	-0.01	-0.38	0.07	1.8	1.70	43.3
1 1/2	1.90	48.3	0.01	0.48	-0.01	-0.48	0.62	15.88	0.28	7.14	0.06	1.60	1.77	45.09	-0.01	-0.38	0.07	1.8	1.94	49.4
2	2.37	60.3	0.02	0.61	-0.02	-0.61	0.62	15.88	0.34	8.74	0.06	1.60	2.25	57.15	-0.01	-0.38	0.07	1.8	2.44	62.2
2 1/2	2.87	73.0	0.02	0.74	-0.02	-0.74	0.62	15.88	0.34	8.74	0.07	1.98	2.72	69.09	-0.01	-0.46	0.09	2.3	2.96	75.2
3	3.50	88.9	0.03	0.89	-0.03	-0.79	0.62	15.88	0.34	8.74	0.07	1.98	3.34	84.94	-0.01	-0.46	0.09	2.3	3.51	89.39
3 1/2	4.00	101.6	0.04	1.02	-0.03	-0.79	0.62	15.88	0.34	8.74	0.08	2.11	3.83	97.38	-0.02	-0.51	0.09	2.3	4.07	103.4
4	4.48	114.0	0.04	1.14	-0.03	-0.79	0.62	15.88	0.34	8.74	0.08	2.11	4.29	109.20	-0.02	-0.51	0.09	2.3	4.48	114.0
5	5.56	141.3	0.05	1.42	-0.03	-0.79	0.62	15.88	0.34	8.74	0.08	2.13	5.39	137.03	-0.02	-0.51	0.11	2.9	5.64	143.5
6	6.62	168.3	0.06	1.60	-0.03	-0.79	0.62	15.88	0.34	8.74	0.08	2.16	6.45	163.96	-0.02	-0.56	0.11	2.9	6.72	170.7
8	8.62	219.1	0.06	1.60	-0.03	-0.79	0.75	19.05	0.46	11.91	0.09	2.34	8.44	214.40	-0.02	-0.64	0.11	2.9	8.72	221.5
10	10.74	273.0	0.06	1.60	-0.03	-0.79	0.75	19.05	0.46	11.91	0.09	2.39	10.56	268.28	-0.02	-0.69	0.14	3.6	10.84	275.4
12	12.75	323.9	0.06	1.60	-0.03	-0.79	0.75	19.05	0.46	11.91	0.10	2.77	12.53	318.29	-0.02	-0.76	0.15	4.0	12.84	326.2

<b>"A" Dimension</b>	The distance from the pipe end to the groove, identifies the gasket seating area. This area must be free from indentations, projections (including weld seams), and roll marks from the pipe end to the groove to ensure a leak-tight seal for the gasket. All foreign material, such as loose paint, scale, oil, grease, chips, rust, and dirt must be removed.
<b>"B" Dimension</b>	The groove width, controls expansion, contraction, and angular deflection of flexible couplings by the distance it is located from the pipe and its width in relation to the coupling housings' "key" width. The bottom of the groove must be free of all foreign material, such as dirt, chips, rust, and scale that may interfere with proper coupling assembly.
<b>"C" Dimension</b>	The proper diameter at the base of the groove. This dimension must be within the diameter's tolerance and concentric with the outer diameter (OD) for proper coupling fit. The groove must be of uniform depth for the entire pipe circumference.
<b>"D" Dimension</b>	The normal depth of the groove, a reference for a "trial groove" only. Variations in pipe OD affect this dimension and must be altered, if necessary, to keep the "C" dimension within tolerance. This groove must conform to the "C" dimension described above.
<b>"T" Dimension</b>	The lightest grade (minimum, nominal wall thickness) of pipe that is suitable for cut or roll grooving.
<b>"F" Standard</b> Roll Groove Only	Maximum allowable pipe-end flare diameter is measured at the extreme pipe-end diameter.

Munro grooved fittings are made to USA standards and adhere to AWWA C-606 groove dimensions.

## Troubleshooting Common Issues - Centrifugal Pumps and Controls

This guide was developed to assist you in troubleshooting common centrifugal pump issues for small turf and irrigation applications (5 hp and below). If you need additional assistance, please contact Munro at 1.800.942.4270 or contact your local irrigation wholesaler.

### Common Issues

- “My pump is running, but the sprinklers are not acting normal.” See Reduced Performance (pg. 243)
- “The pump is running, but there is no water coming out.” See Pump Runs But No Water (pg. 244)
- “The water comes out, then goes away. Then it comes out...” See Pump Surging/Flow Cycles (pg. 245)
- “The motor just sits there and hums.” See Motor Hums (pg. 246)
- “When I turn the pump on, nothing happens.” See Motor Does Not Run At All (pg. 247)
- “The pump runs for a little while and then stops and then starts again.” See Motor Cycles and/or Nothing Happens (pg. 248)
- “Nothing is happening. I have a pump start relay.” See StartBox (pg. 249)
- “My pump runs for 30 seconds and shuts off and does not restart.” See SmartBox (pg. 250)

### Evaluating the System

- |  |   |
|--|---|
| <ol style="list-style-type: none"> <li>1. Have there been any changes to the system environment?             <ol style="list-style-type: none"> <li>a. New fencing – Possible damage to pipework</li> <li>b. Added zones – Pump is now undersized</li> <li>c. Aeration or animals – Possible damage to sprinkler heads or pipework</li> <li>d. Water source – Lower levels than usual</li> </ol> </li> <li>2. Look for obvious problem areas             <ol style="list-style-type: none"> <li>a. Leaking from case or seal area</li> <li>b. Cracked or worn components</li> <li>c. Clogged filters or screens</li> <li>d. Damaged gaskets in camlocks and o-rings</li> </ol> </li> </ol> | <ol style="list-style-type: none"> <li>3. Determine the primary issue             <ol style="list-style-type: none"> <li>a. Reduced Performance (pg. 243)</li> <li>b. Pump Runs but No Water (pg. 244)</li> <li>c. Pump Surging/Flow Cycles (pg. 245)</li> <li>d. Motor Hums (pg. 246)</li> <li>e. Motor Does Not Run (pg. 247)</li> <li>f. Motor Cycles (pg. 248)</li> <li>g. Munro StartBox (pg. 249)</li> <li>h. Munro SmartBox (pg. 250)</li> </ol> </li> </ol> |
|--|---|

### Safety Precautions

- Remember when using any tool, refer to the manufacturer’s guidelines for proper use.
- ALWAYS turn the breaker off to work on a pump. Some troubleshooting checks require the pump to be energized, be sure the area is secure prior to the task. Be sure to turn the breaker off again if problem persists.
- NEVER examine, make wiring changes, or touch the motor before disconnecting the electrical supply. Thermal overload protectors automatically reset and can close the electrical circuit without warning.

## How To

### Check Volts Entering Pump



While the motor is running, use a voltmeter to determine if line voltage getting to the motor is the same as indicated leaving the breaker box.

### Check for Air Leaks Using Plastic Wrap



Wrap plastic wrap tightly around a potential air leak path (union joint or cam fitting), turn pump on. If an air leak exists, the plastic wrap will tighten to the area.

### Clear Centrifugal Switch



Debris can get caught in the centrifugal switch inside the motor. Jostling or tapping the motor near the rear plastic cover may free the switch.

### Access the Wrench Slot



Check the motor shaft for a slot to fit an open-ended wrench. This can aid in diagnosis and tear-down/assembly procedure.

### Tear Down and Reassembly of a Pump, Including to Replace a Seal or Clean the Impeller



Refer to the Owners Manual for instructions on tearing down the pump to replace the seal, clean the impeller, or access the inside of the pump for any reason. Visit our YouTube channel for instructional videos: [www.youtube.com/users/munrocompanies](http://www.youtube.com/users/munrocompanies)

## Tools You May Need

- Soft faced hammer or 2x4 board
- Thin profile wrench – 9/16 and 5/8
- Wrench or socket set
- Voltmeter
- Pry bar
- Flathead screwdriver
- Plastic wrap
- Lubricant
- Pipe wrench



#### Did You Know?

A pressure gauge on the pump is a good indicator of system performance. Low pressure while the pump is running indicates a suction or obstruction problem. Normal pressure readings at the pump commonly indicate a sprinkler head or pipework problem.



#### Did You Know?

80% of all pump issues are on the suction side.

## Possible Replacement Parts

- Gaskets: case, diffuser, cam fitting
- Mechanical shaft seal
- Union o-rings

# Troubleshooting Guide - Reduced Performance



### Did You Know?

You cannot always find a suction leak by pressurizing a line. Air can seal under pressure but will enter pipe in a vacuum.

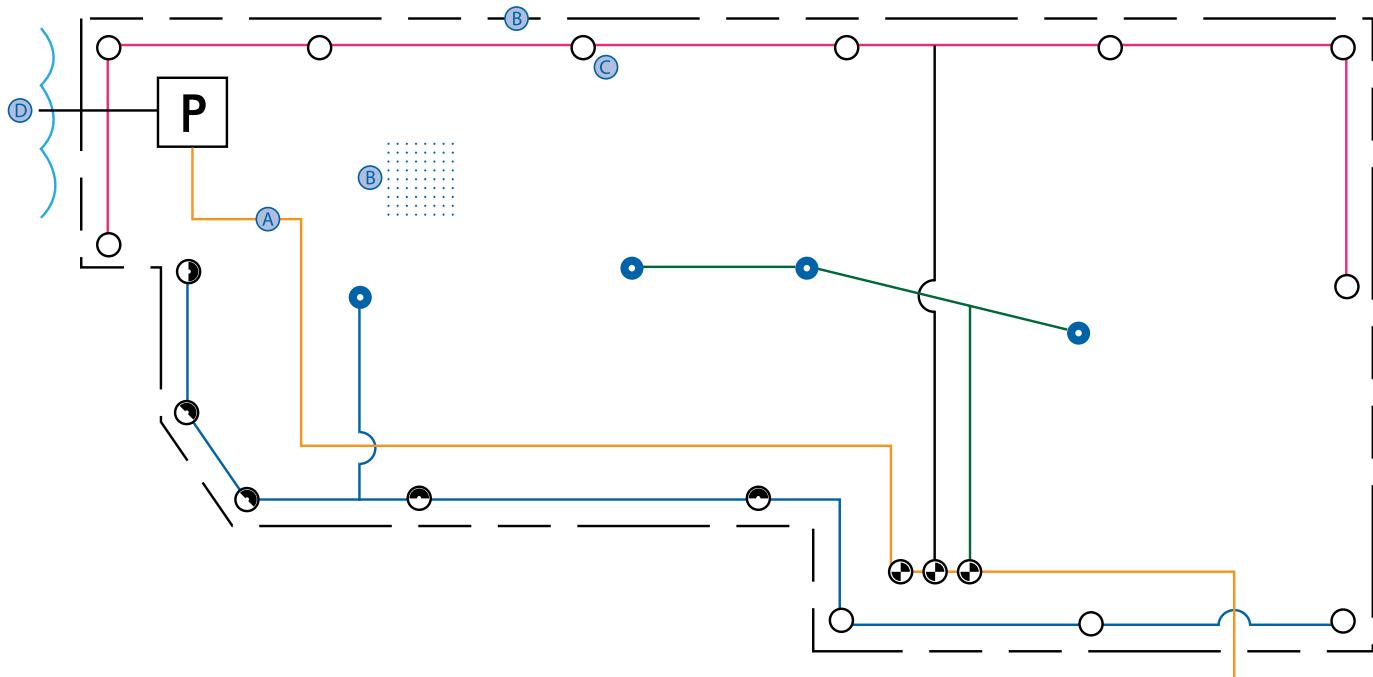
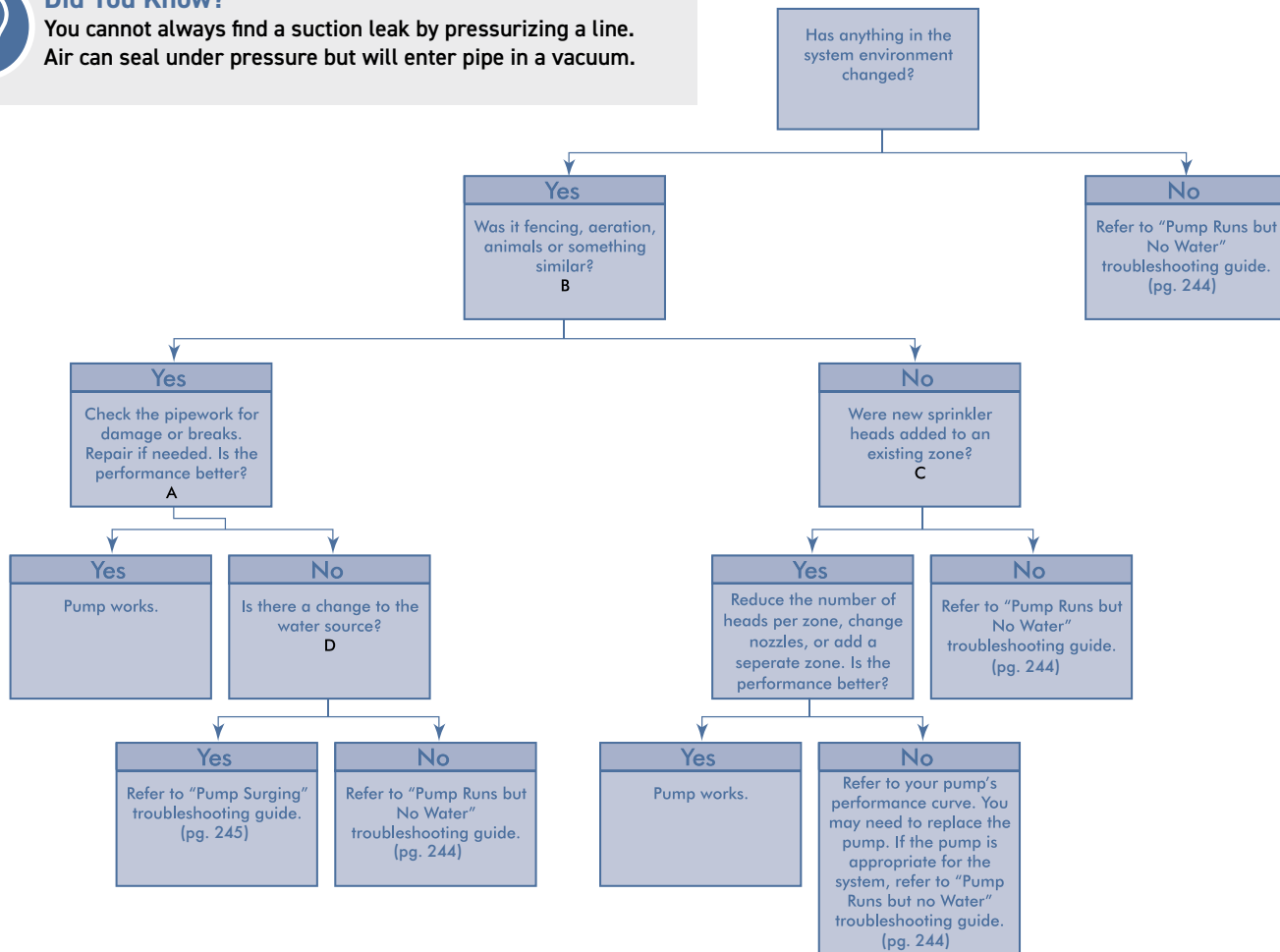

RESOURCES

## Troubleshooting Guide - Pump Runs but No Water



### Did You Know?

Cam fittings are best used with the handles to the top and bottom. It reduces the chance of leaking from the weight of the hose.

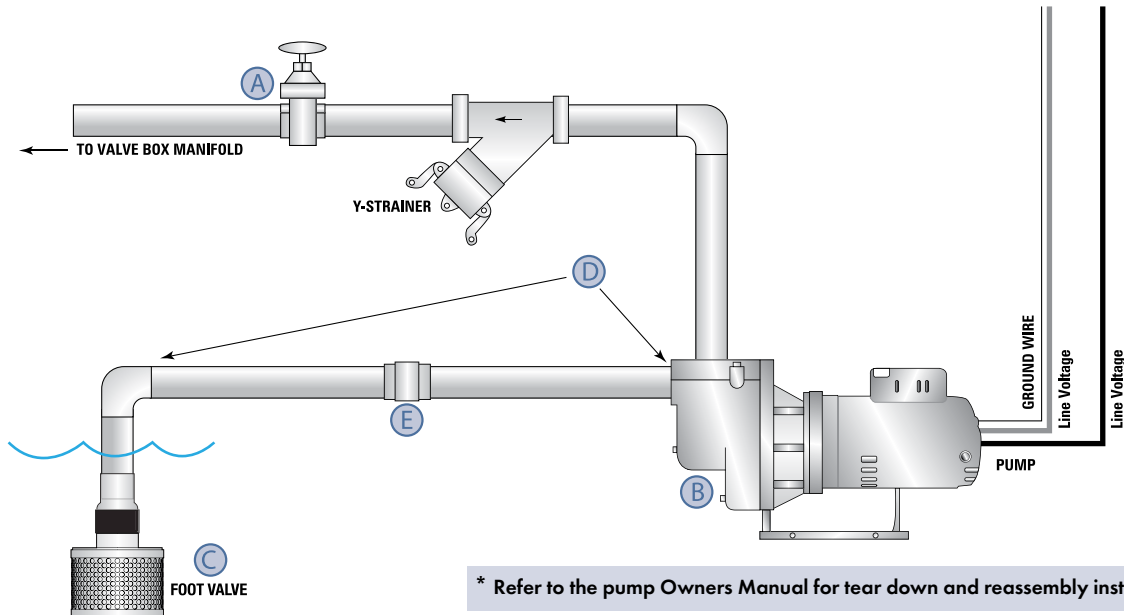
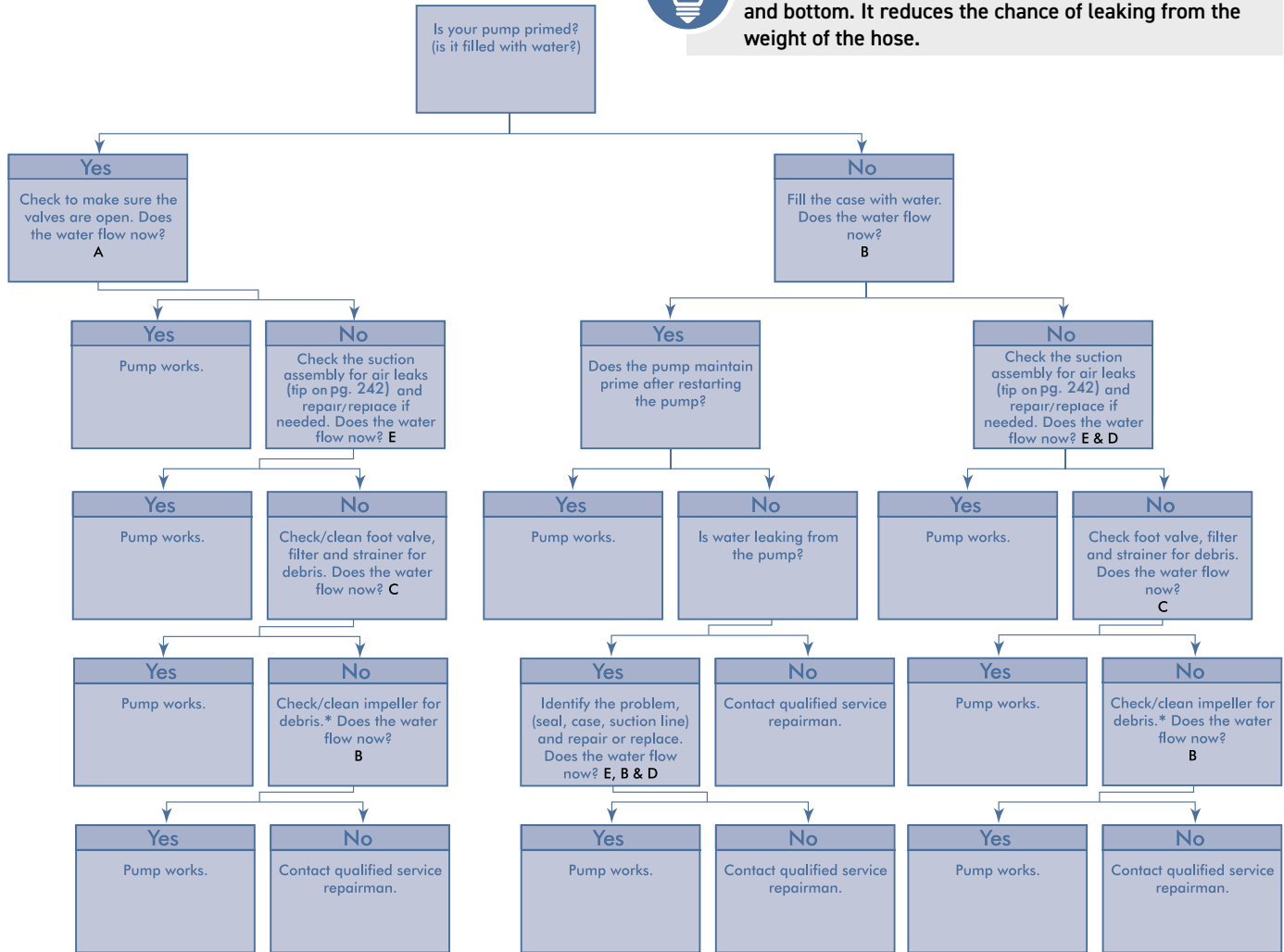

\* Refer to the pump Owners Manual for tear down and reassembly instructions.

# Troubleshooting Guide - Pump Surging (Flow Cycles)



### Did You Know?

Union joint O-rings and cam fitting gaskets should be inspected or replaced every year or two. O-rings and gaskets can harden over time and become brittle, causing air leaks.

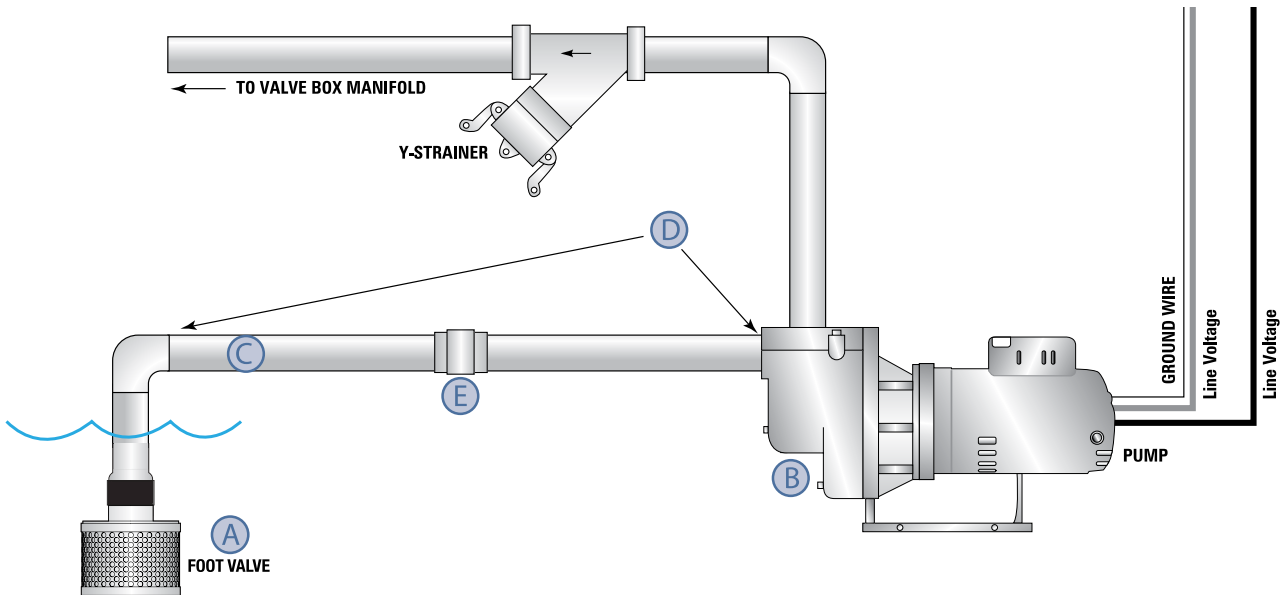
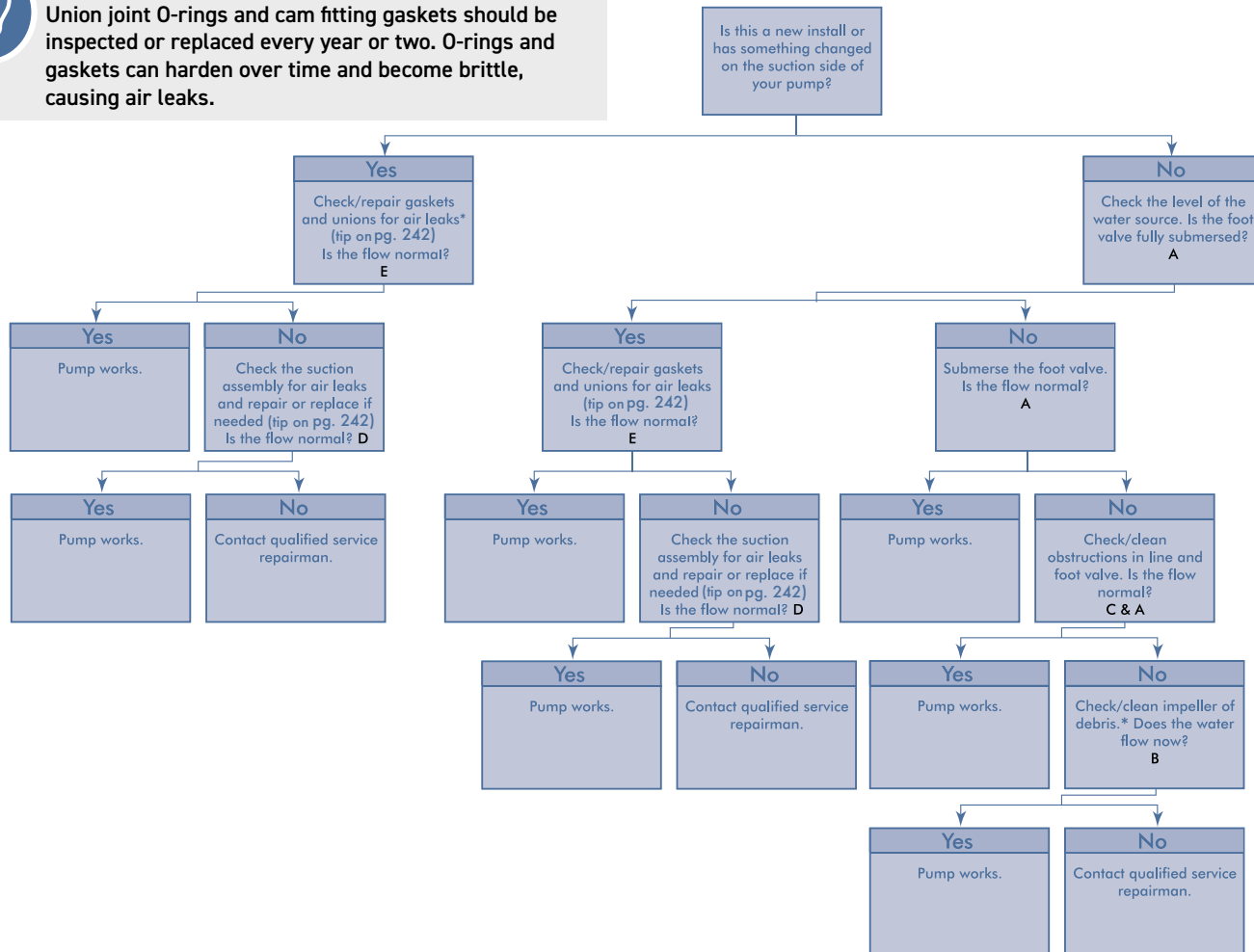

\* Refer to the pump Owners Manual for tear down and reassembly instructions.

## Troubleshooting Guide - Motor Hums



### Did You Know?

To avoid an unnecessary trip, try jostling any debris inside the pump free before bringing your pump to a repairman. (Tip on pg. 242 "Clear Centrifugal Switch")

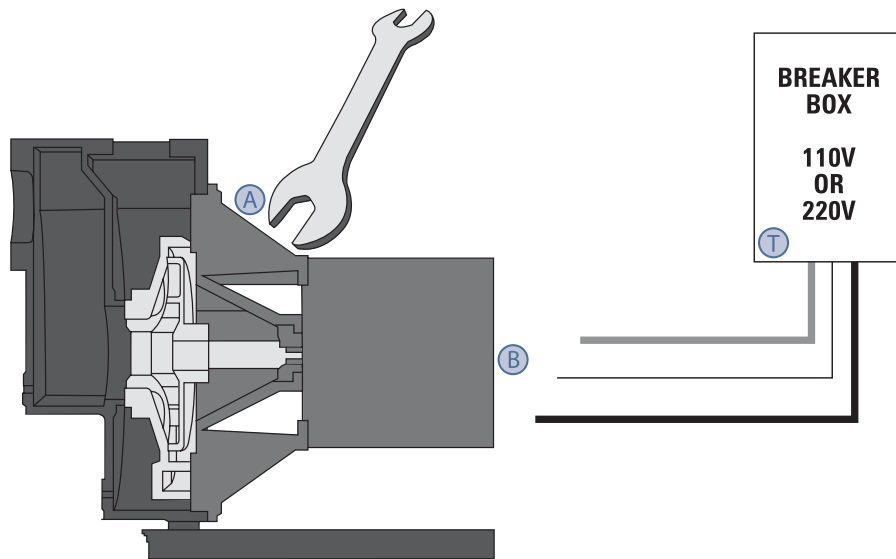
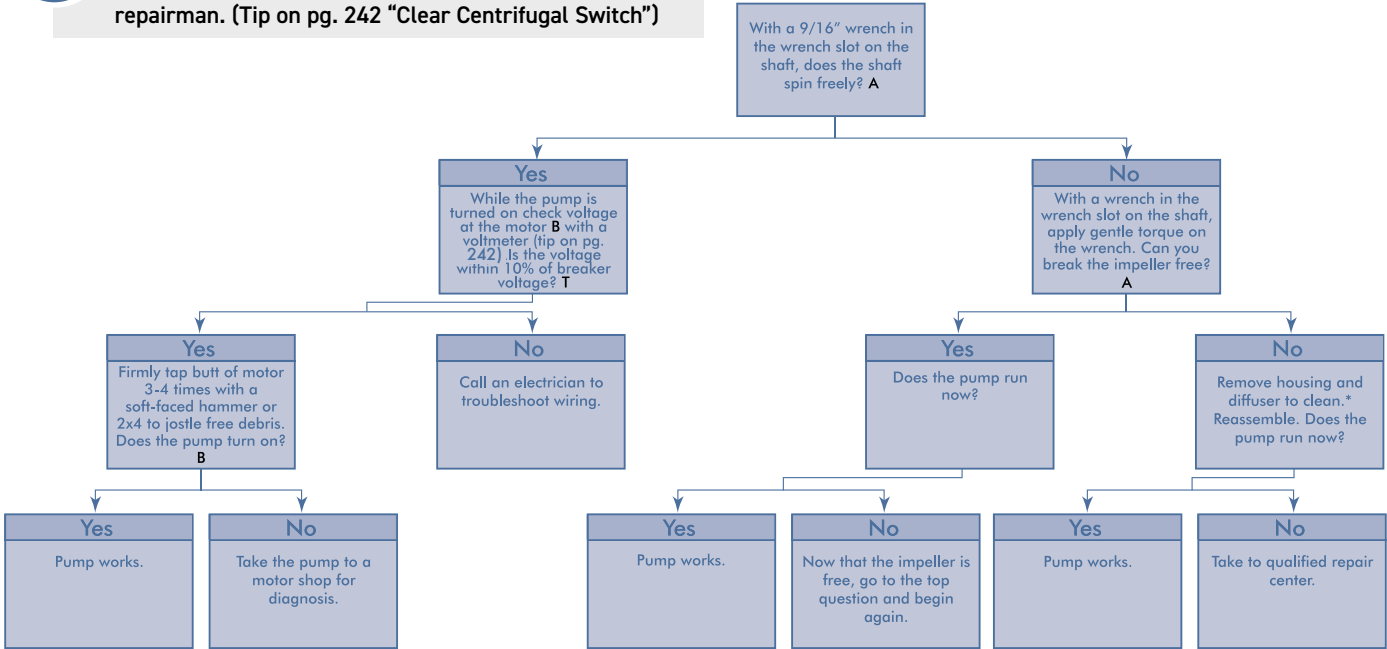

\* Refer to the pump Owners Manual for tear down and reassembly instructions.

# Troubleshooting Guide - Motor Does Not Run at All



**Did You Know?**

A motor may start with low voltage but cannot maintain running at low voltage. It will eventually wind down to a stop or burn the winding's insulation.

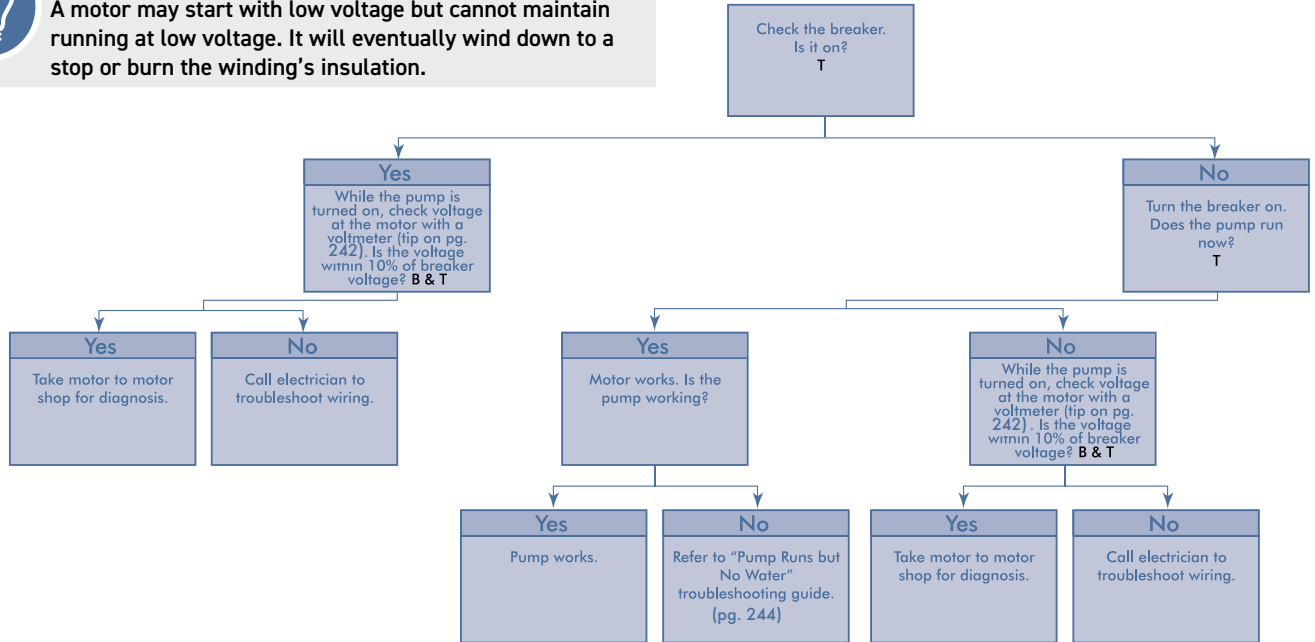

**Did You Know?**

A two-pole motor with 60 cycle current will run at a nominal 3600 RPM.

**Note:** For systems without a pump start relay, also see pg. 245. For systems with a pump start relay, also see pg. 245-247.

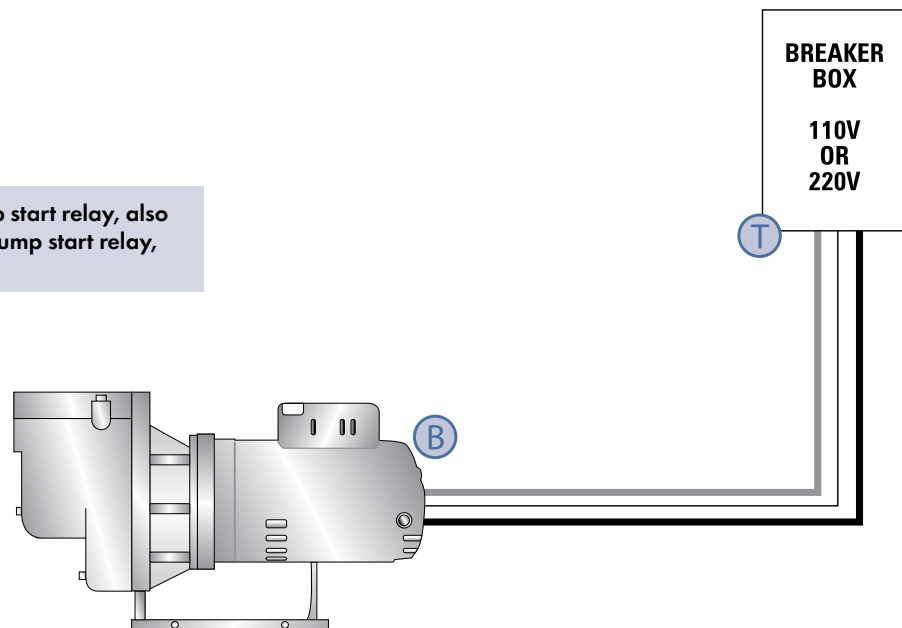

## Troubleshooting Guide - Motor Cycles and/or Nothing Happens



### Did You Know?

A capacitor start motor has an average of 1.5 times more torque during the start process.

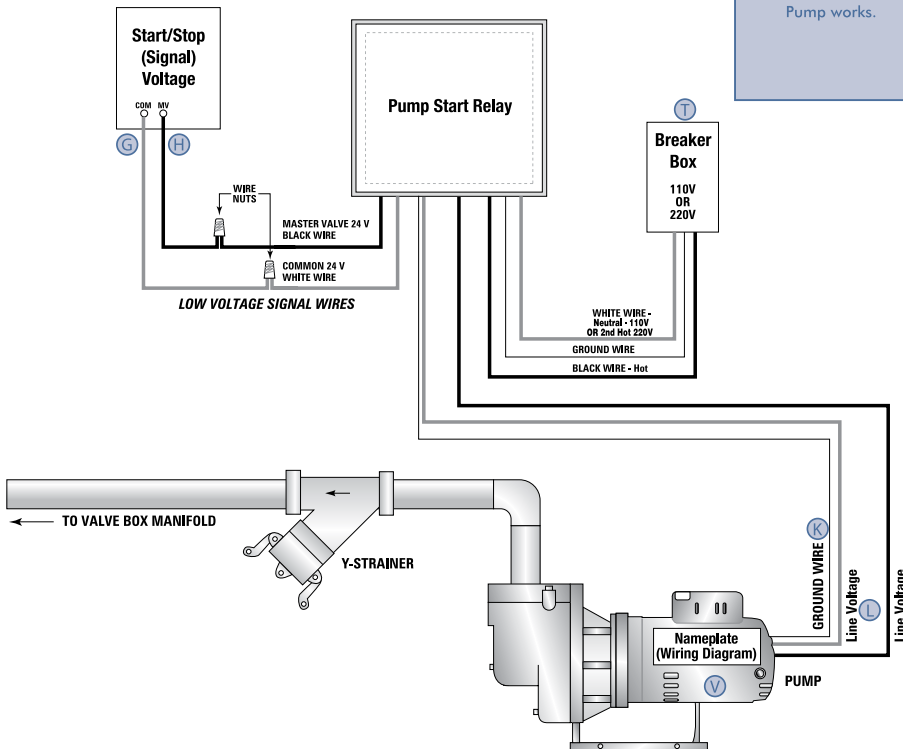
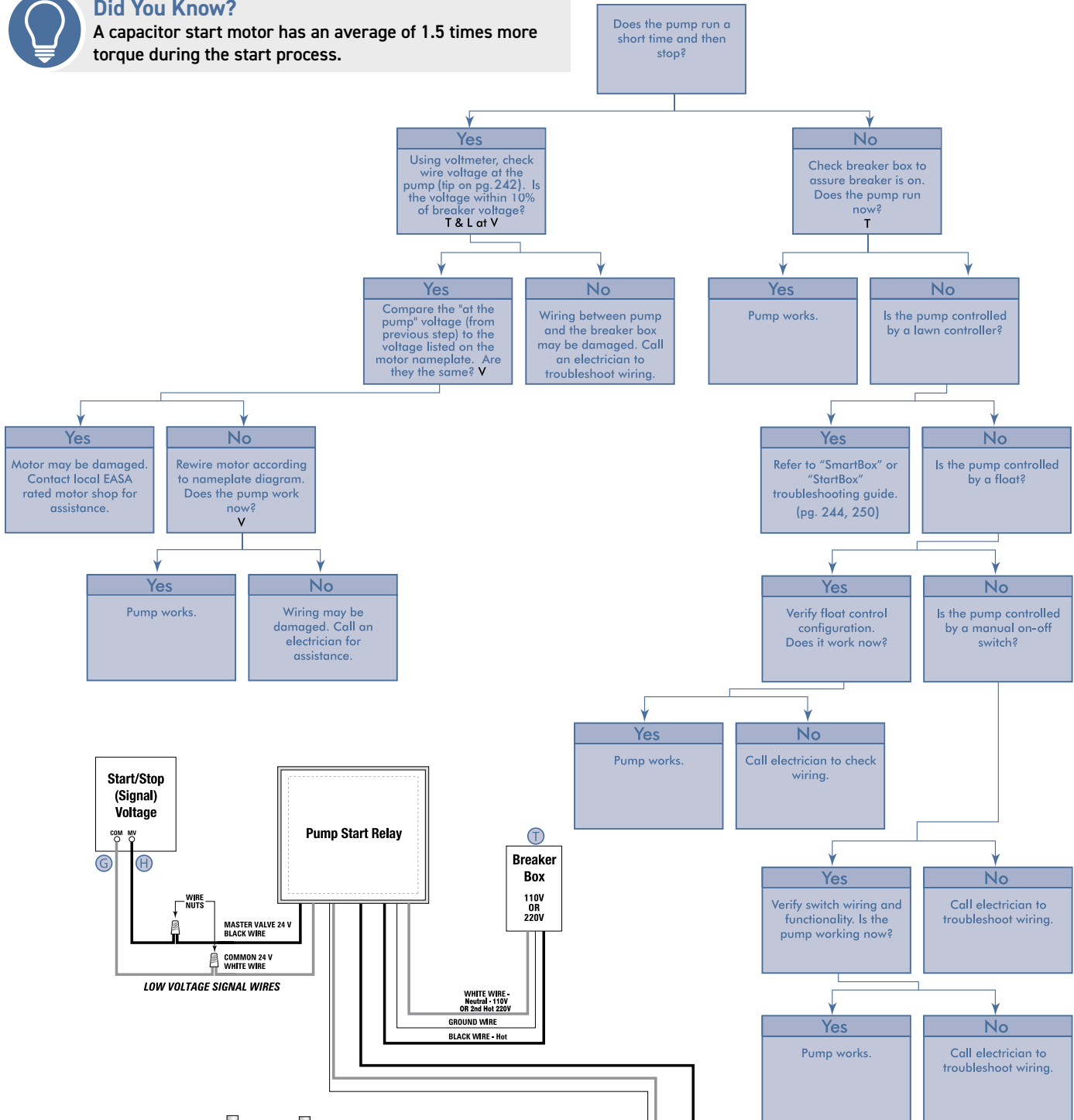

# Troubleshooting Guide - StartBox



**Did You Know?**  
A pump start relay can be signaled by a float switch.

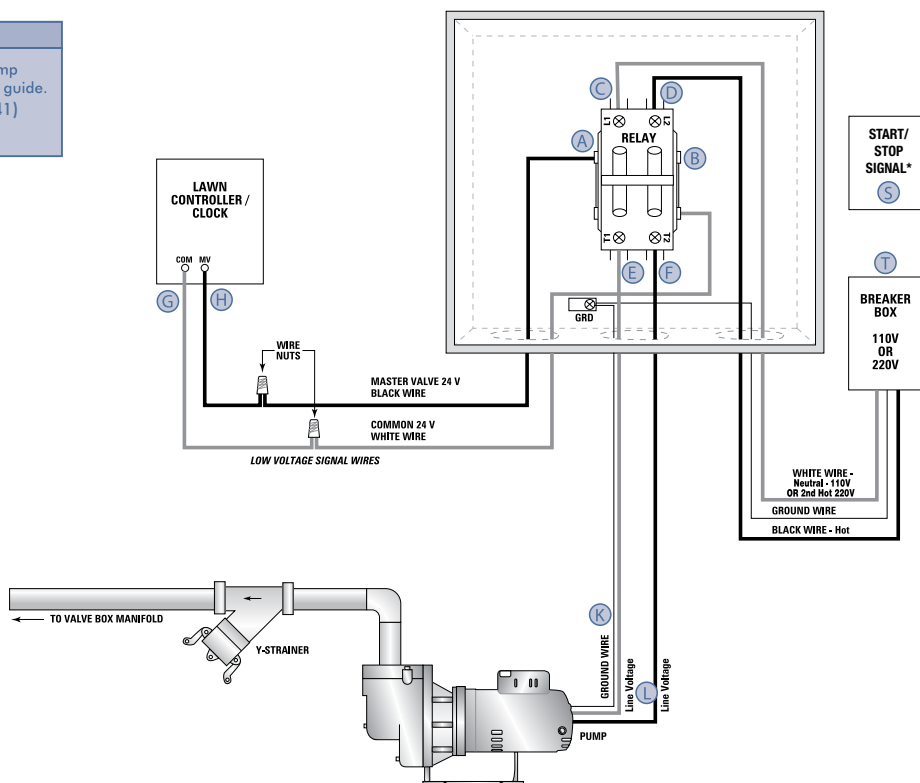
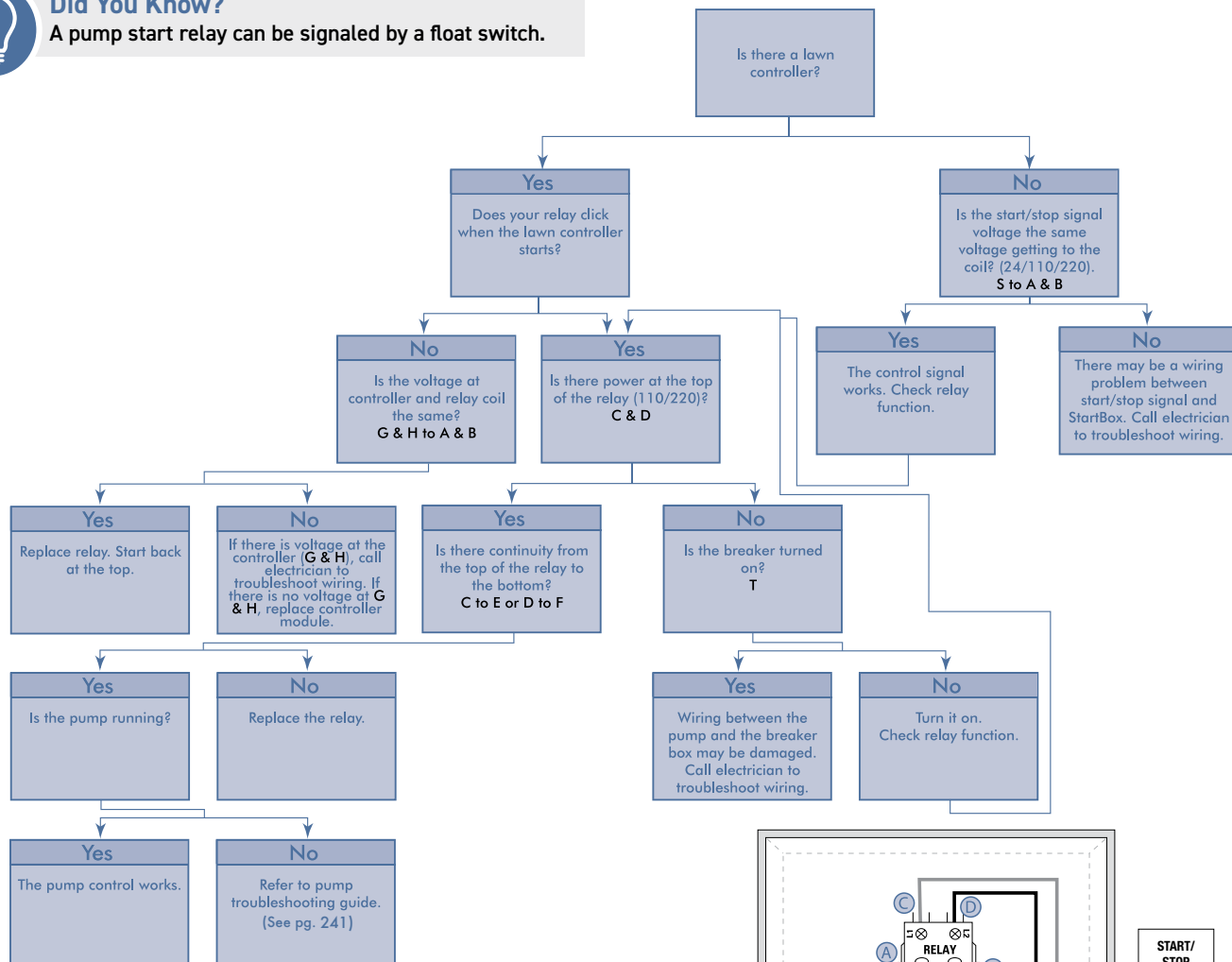

**Note:** Start/Stop signals include, but not limited to, float switches, HOA's, timers etc.

**Note:** The StartBox & SmartBox troubleshooting guides do not apply to 2-wire decoder systems.

## Troubleshooting Guide - SmartBox



### Did You Know?

During a normal "run" cycle, no lights should be lit on the time delay. Should a sensor detect a possible system problem, the "on" light will engage. If the system is shut down during a cycle both the "on" and "up" lights will be lit for the duration of the lawn controller cycle.

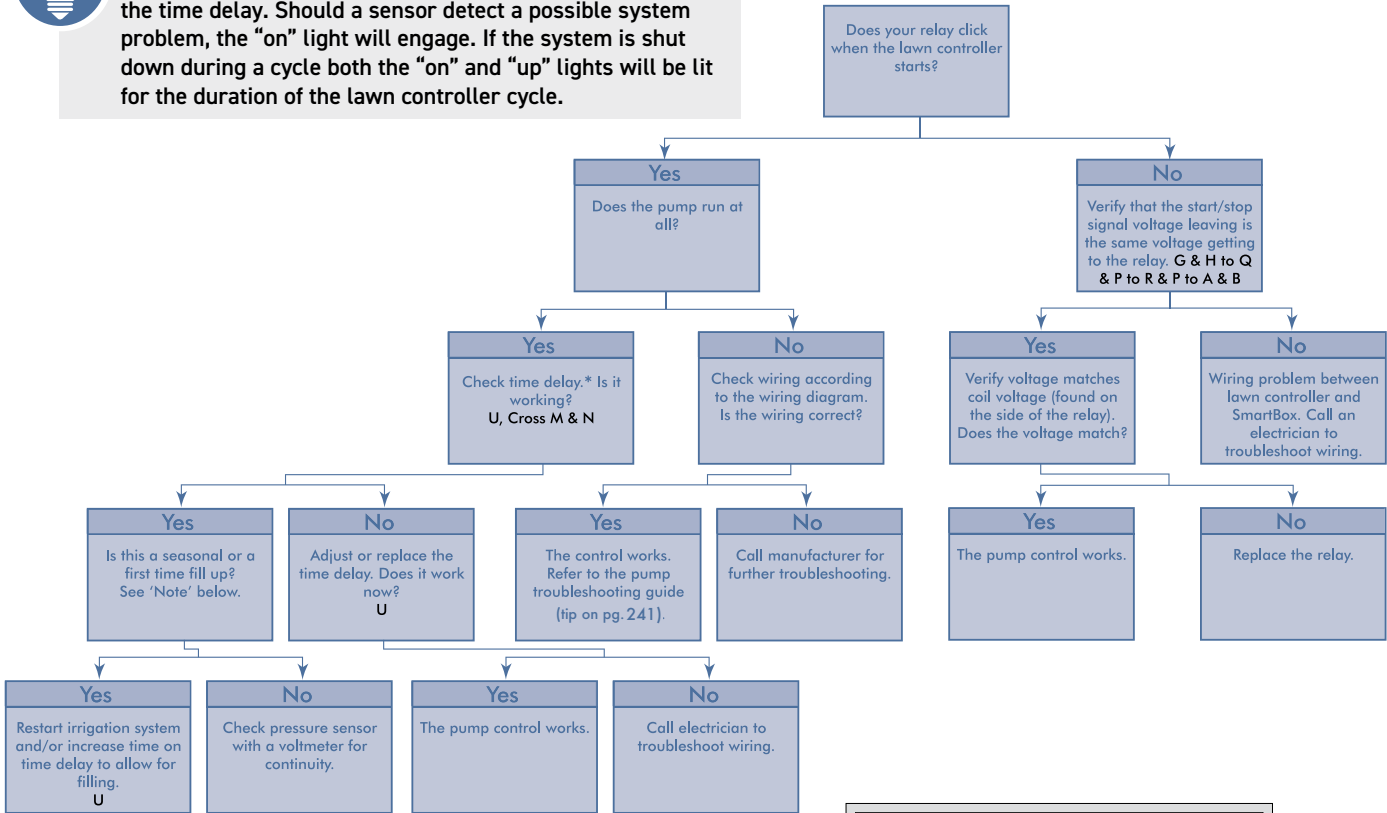

\* Turn the time delay down to 5 seconds. Next, cross the red and blue wire. The "on" light should turn on. After 5 seconds the system should shut off and both the "on" and "up" lights should be on.

Note: Filling system lines may require multiple run cycles to build enough pressure to initiate the sensor.

**OPTIONAL DOMESTIC VALVE:** When low pressure occurs, a 24 VAC valve can be energized. Call Munro for additional information about wiring this component.

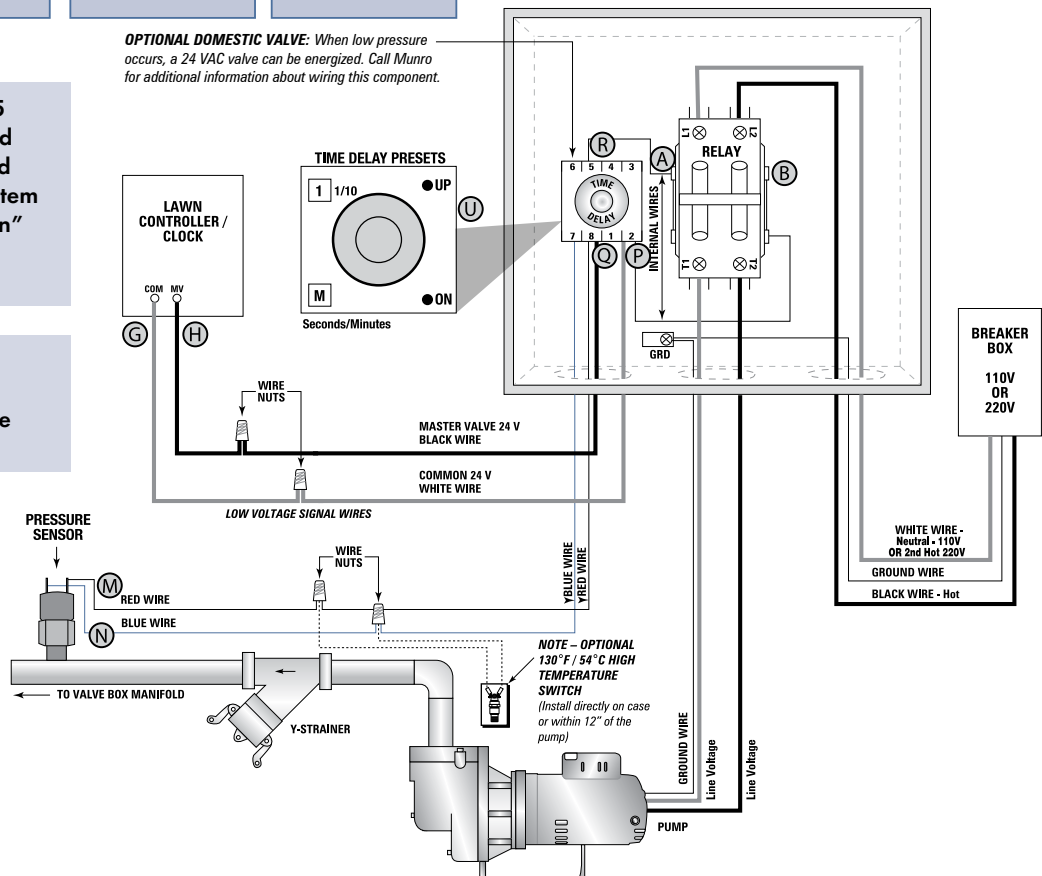

# Troubleshooting Guide - MPLC242W22T

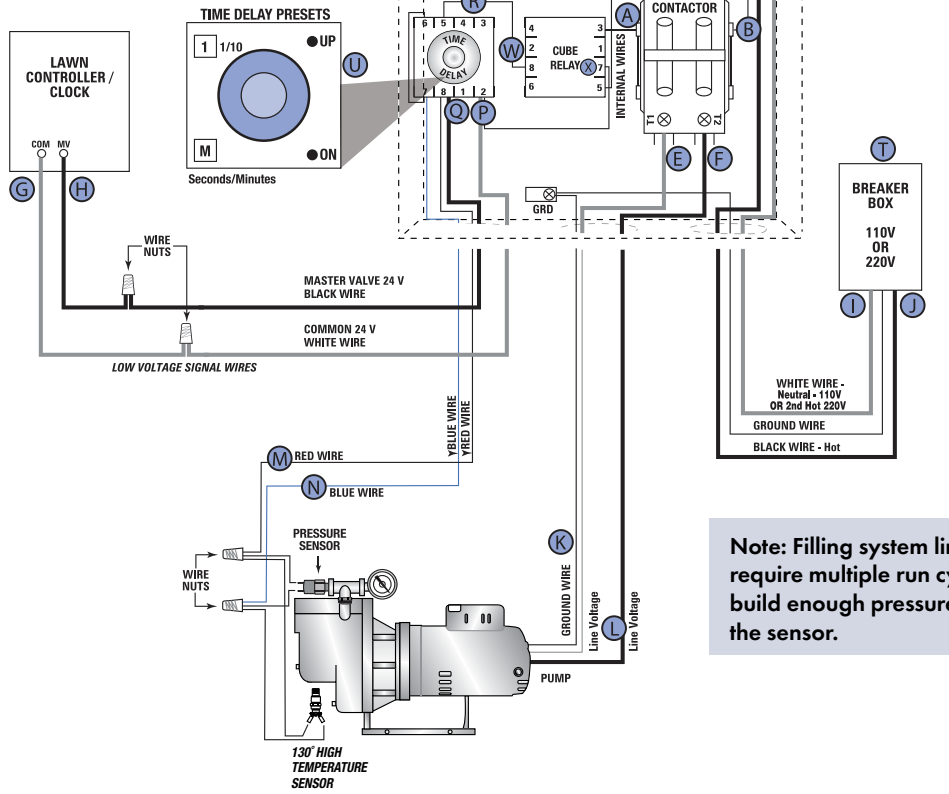
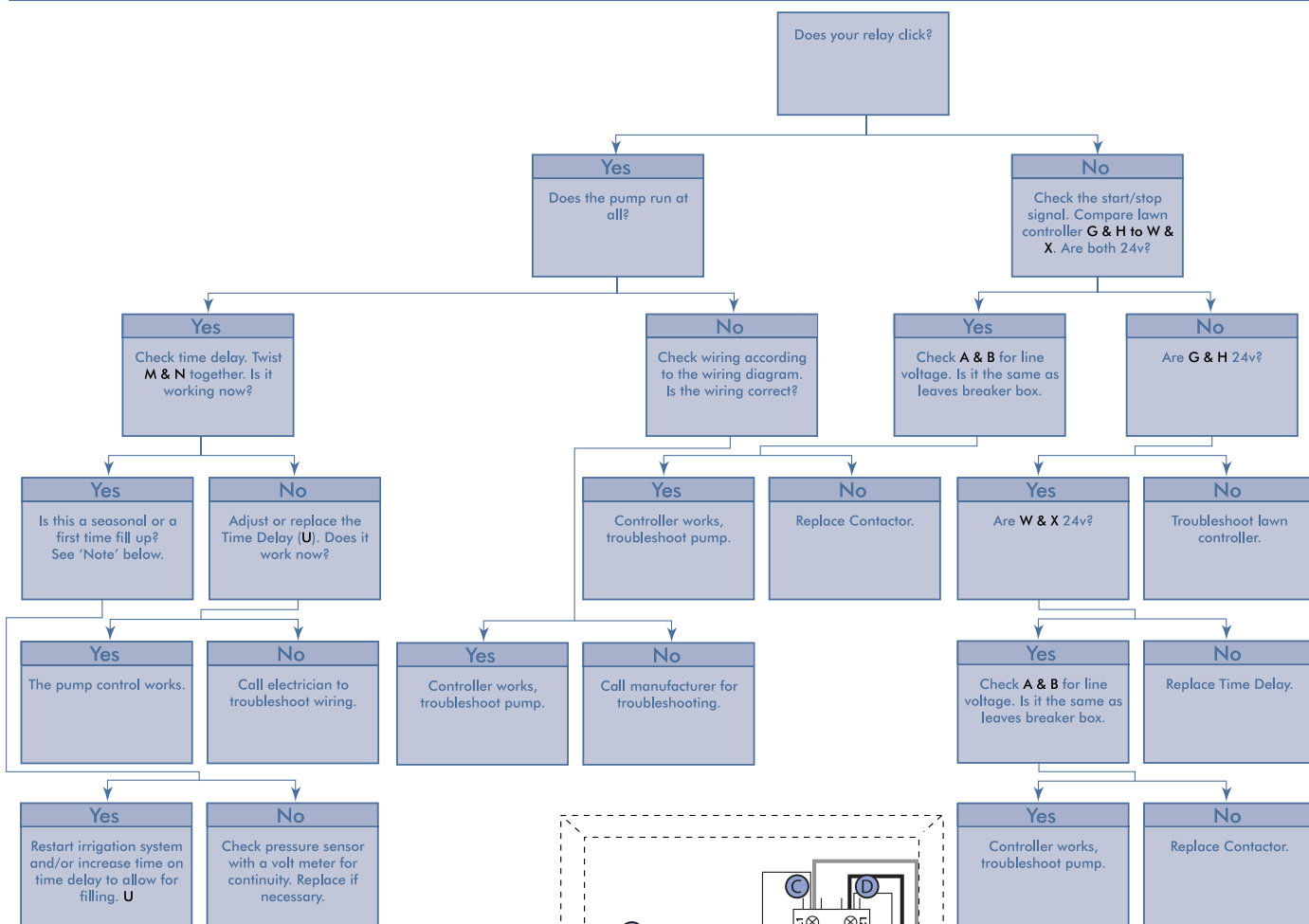

**Note:** Filling system lines may require multiple run cycles to build enough pressure to initiate the sensor.

## Irrigation Pump Wiring Instructions

### READ AND FOLLOW SAFETY INSTRUCTIONS!

**⚠ This is the safety alert symbol.** When you see this symbol on your pump or in this manual, look for one of the following signal words and be alert to the potential for personal injury.

**⚠ DANGER** warns about hazards that **WILL** cause serious personal injury, death or major property damage if ignored.

**⚠ WARNING** warns about hazards that **CAN** cause serious personal injury, death or major property damage if ignored.

**⚠ CAUTION** warns about hazards that **WILL** or **CAN** cause minor personal injury or property damage if ignored.

The label **NOTICE** indicates special instructions which are important but not related to hazards.

### MOTOR AND ELECTRICAL:

Carefully read and follow all safety instructions in this manual and on the pump.



**Electric pump motors can be hazardous if not properly installed. Call a licensed electrician if unsure of any electrical connection.**

#### GENERAL SAFETY – ELECTRICAL

- ⚠ WARNING** Every time work is to be performed on a pump, the power supply should be terminated at the breaker box.
- ⚠ WARNING** Follow all local electrical and safety codes, including the National Electrical Code (NEC) and the Occupational Safety and Health Act (OSHA).
- ⚠ WARNING** Replace damaged or worn cords immediately.
- ⚠ WARNING** Ground motor before connecting to power supply.
- ⚠ WARNING** Use extreme caution around an operating pump and motor – it may be hot enough to cause serious burns.

#### GENERAL OPERATION – ELECTRICAL

- Refer to motor nameplate to verify that supply voltage and motor wiring is the same.
- Verify motor phase against supply power phase.

#### GENERAL SAFETY – MOTOR

- ⚠ WARNING** Disconnect the main power before handling the unit for ANY REASON.
- ⚠ WARNING** An operating motor can run between 250°F and 311°F depending on insulation rating. Never touch a motor without first determining the housing temperature.
- Keep pump motor ventilated to reduce damage due to heat.
- ⚠ DANGER** Motor is not waterproof and should never be submersed into any liquid.
- Motor is designed to work with up to a 15 degree angle of water impact. Do not allow water to spray directly onto motor. External motor protection should be used to eliminate environmental concerns.

- To reduce the risk of electric shock, the motor must be securely and adequately grounded. Refer to National Electric Code (NEC Article 250 – Grounding) for additional information.
- When in doubt, call a licensed electrician. High voltage can shock, burn or cause death.

### WIRING CONNECTION:

Refer to the connection diagram located on the nameplate of the motor.

#### GROUNDING

- Grounding the motor can be achieved by securing the motor to a metal raceway system. Alternately a separate grounding wire connected to bare metal on the motor frame, or to the green grounding screw located inside the motor terminal box, or other suitable means is acceptable. (Refer to NEC Article 250 – Grounding for specifics.)
- Verify motor grounding provision on the nameplate before connecting any wires to the motor.

#### ROTATION

- When facing the suction tapping, all Munro pumps run in a Counter-Clockwise (CCW) rotation only. Rotation from the motor end perspective is Clockwise (CW) and is marked as such on the motor nameplate. Tampering with, or reversing, the rotation will damage your pump and void the warranty.

#### CHECK MOTOR ROTATION – 3 PHASE

- A fractional second application of power should be applied to all 3-phase motors to verify rotation of shaft as described above. This is sometimes referred to as “bumping the motor”.
- Improper rotation can cause catastrophic pump failure and voids the warranty.
- Reversing two of the three power wires makes the motor run in the opposite direction.

#### MOTOR PROTECTION

- Fuses and circuit breakers are used as a safety device for the wire circuit. They do NOT offer motor protection.
- Consult local or national electric codes for proper fuse protection based on the motor data located on the motor nameplate.

#### THERMAL OVERLOAD

- Refer to motor nameplate to verify the presence of overload protection.
- Overload protects the motor from high and low voltage irregularities.
- All motors must be thermally protected – either within the motor or externally.
- ⚠ WARNING** The internal overload is usually automatic and resets itself once the temperature has dropped to a safe point.
- Frequent tripping of the overload indicates motor or power problems. Immediate professional attention is recommended.
- ⚠ WARNING** NEVER examine, make wiring changes or touch the motor before disconnecting the electrical supply. Thermal overload protectors automatically reset and can close the electrical circuit without warning.
- ⚠ WARNING** The overload should never be tampered with or removed.

# Irrigation Pump Operation

## PUMP:

### GENERAL SAFETY – PUMP

1. **⚠ WARNING** An operating pump, with a blocked discharge, will heat the water and pump housing. Allow pumps to cool before handling.
2. High temperature sensors can help protect plastic plumbing from disfiguring and/or expanding.
3. Running a pump without water may cause damage to the seal.

### GENERAL OPERATION – PUMP

1. Locate the pump as close to the water source as is practical.
2. Total suction lift (vertical lift plus any friction loss in suction line) should not exceed 10' for optimal performance. Suction lift of 15' is attainable depending on elevation, water temperature, and atmospheric condition. Pump performance is affected when suction lift exceeds 15'.
3. Fill the pump case and suction pipe with water to expel as much air as possible prior to start-up. Running a pump dry may cause damage to the seal and void warranty.
4. Pump and pipe must be drained if there is any danger of freezing.

### PIPE CONNECTION

1. Plastic or galvanized steel pipe are most commonly used. Support pipe as needed.
2. Keep suction and discharge lines as large as possible. Pipe should not be smaller than the corresponding suction and discharge holes.
3. Avoid excess fittings when possible. Use straight runs when possible.
4. All joints and connections should have pipe-specific sealing compound applied and be completely tightened.
5. Isolation valves or unions on suction and discharge allow for easy pump removal, especially with multi-pump or positive inlet pressure applications.
6. Suction pipe should never have a higher elevation than the pump.

## OPERATION:

### INITIAL PRIMING

1. Unit must be full of liquid before operating. Never run dry. Running a pump dry may cause damage to the seal and void the warranty.
2. Remove one priming plug from pump housing and fill the pump body and suction line completely with water. Unit must be full of liquid before operating. Never run dry. Running a pump dry may cause damage to the seal and void the warranty.
3. Normal system start-up will take a few minutes for air to expel from system and water to begin to cycle – depending on suction lift. If no water is flowing after a few minutes, turn the pump off and refer to troubleshooting guide (p.244). Do NOT run pump dry for any period of time.
4. Do not run against a closed discharge for more than a few minutes.

### ROTATION

1. Single phase motors are pre-wired for CCW, as viewed from suction tapping, and should never be reversed.
2. Three phase motor rotation must be verified at job site.

### MAINTENANCE – LUBRICATION

1. No lubrication is required. The ball bearings are permanently lubricated and sealed at the factory.

### MAINTENANCE – FREEZING

1. Drain the entire system if there is a danger of freezing.
2. Drain plugs are provided in both upper and lower pump case chambers.
3. Filling the pump with non-toxic Munro Freeze Defeat and

replacing the plugs, will reduce the oxidation in the case over the winter. Before spring start-up, drain the Munro Freeze Defeat from the case.

## RECOMMENDED OPTIONAL EQUIPMENT:

1. Strainer – Use of strainers prevent large debris from entering pump system through suction line.
2. Pressure Gauge – Use of a pressure gauge helps to troubleshoot and identify a pump or system issue.
3. Discharge Valve – Use of a gate or ball valve on the discharge side of a pump allows pump isolation for removal.
4. Foot Valve – Use of a foot valve (or check valve) can aide the priming of a centrifugal pump. If suction lines are kept full, the pump does not have to evacuate the air before pumping water.

## ROTARY SEAL ASSEMBLY REPLACEMENT:

**⚠ CAUTION** Make certain the power supply is disconnected before attempting to service the unit!

### SEAL REMOVAL

1. Remove the case bolts and separate pump case from motor assembly.
2. Remove diffuser bolts and diffuser from motor assembly.
3. Insert an open-end thin profile 9/16" wrench into the side of the mounting ring, slowly turning the impeller until the wrench seats itself onto the flats of the shaft. Once properly seated, the wrench will prevent the shaft from turning. For 3ph and LP3005 models removal of the shaft, bolt and washer(s) (if present) is necessary prior to removal of the impeller.
4. With the wrench in place (#3) spin the impeller counter-clockwise to expose seal assembly area. LP3005 models: Gently rap outward on the shaft key to remove the key and impeller.
5. The seal spring will release as the impeller is removed. LP3005 models have a retaining clip in place. Carefully remove the clip to release the spring and impeller.
6. Being careful not to damage the motor shaft, remove the seal head, seat and rubber from the seal pocket. The use of a flat head screw driver or similar tool may be necessary.
7. If necessary, remove the mount ring bolts and mount ring to gain better access to the seal.
8. Once the seal is removed, clean the pocket removing all debris.

**⚠ CAUTION** The rotary seal assembly must be handled carefully to avoid damaging the precision lapped faces of the sealing components.

### SEAL INSTALLATION

*NOTICE: It is recommended to only install new seals. Do not install used or dirty seals.*

*NOTICE: Application of a light coat of multi-purpose water-based lubricant to the outer diameter of the rubber seat may make installation easier. Be certain both seal face surfaces are kept clean.*

1. Insert the stationary seal face and elastomer seat into the recessed area of the mount ring.
2. Slip the rotating seal face assembly onto the motor shaft.
3. Using uniform pressure, be sure the seal's seat has completely bottomed-out in recessed area.
4. After placing the spring, install the impeller and bolt the diffuser onto the motor assembly. Manually turn impeller to verify smooth operation.
5. Replace and bolt the pump body to the motor assembly.

## Rotary Seal Assembly Replacement

**CAUTION** Make certain the power supply is disconnected before attempting to service the unit!

### Seal Removal

1. Remove the case bolts and pump body from motor assembly.
2. Remove diffuser bolts and diffuser from motor assembly.
3. Insert an open-end 9/16" (LP075B, LP100B, LP150B, LP200B, LP300B) or an 5/8" (LP1502B) wrench into the side of the mounting ring, slowly turning the impeller until the wrench seats itself onto the flats of the shaft. Once properly seated, the wrench will keep the shaft from turning. LP3005B model uses keyed shaft and sleeve. Removal of these impellers may require high heat to remove the shaft sleeves.
4. Expose the seal assembly by spinning the impeller counterclockwise to un-thread it from the motor shaft.
5. The seal spring will release as the impeller is removed.
6. Being careful not to damage the motor shaft, remove the seal head, seat and rubber from the seal pocket. The use of a screwdriver or similar tool may be necessary.
7. Should the seal be difficult to remove, the mounting ring can be completely removed for easier access by taking out the mount ring bolts.
8. Once the seal is removed, clean the pocket removing all debris.

**CAUTION** The rotary seal assembly must be handled carefully to avoid damaging the precision lapped faces of the sealing components.

### Seal Installation

**NOTE:** It is recommended to only install new seals. Do not install used or dirty seals.

**NOTE:** Application of a light coat of multi-purpose chassis grease to the diameter of the rubber gasket may make installation easier. Be certain the seat is kept clean and free of dirt and/or grease at all times.

1. Insert the seal seat rubber gasket into the recessed area of the mount ring.
2. Slip the seal head assembly onto the motor shaft.
3. Using uniform pressure, be sure the seal's seat or mounting ring has completely bottomed-out in recessed area.
4. After placing the spring, install the impeller and bolt the diffuser onto the motor assembly.
5. Replace and bolt the pump body to the motor assembly.



### Did You Know?

By touching the seal face, the oil from your skin will shorten the life of the seal.

# Float Switch 101

## Basics of a mechanical float switch

Mechanical float switches are normally activated by an internal, movable part. In the diagram to the right, the Ball is used to pressure the Actuation Arms to engage the On/Off Switch when the float changes positions.

It is important to note, the switch can be wired to either turn On or to turn Off with activation. The position of the float, when *hanging*, designates whether the switch is 'normally open' or 'normally closed'.

If the On/Off switch, as shown to the right, is wired to activate (close a circuit) when pushed, this would be considered a 'normally open' float. The float is hanging and the circuit is open.

Conversely, if the switch is wired to open a circuit when pushed, this diagram would depict a normally closed circuit. The hanging float is closed and would open with the change of position.

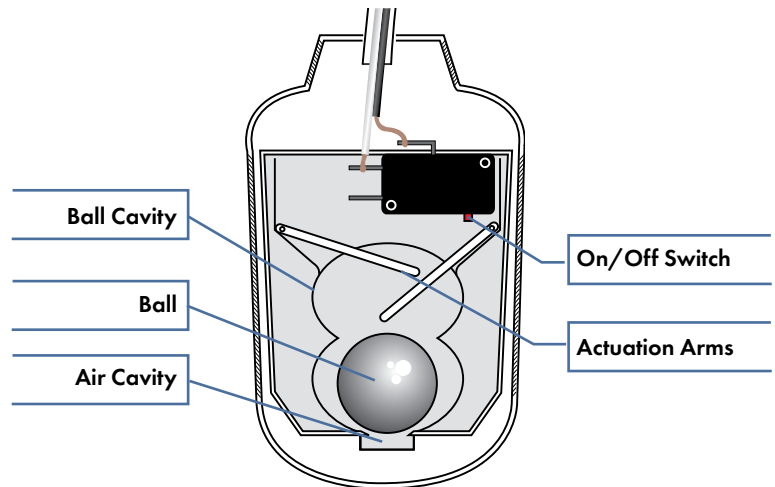

## Practical Use/Application

Float switches are often used to monitor tanks, cisterns, lakes and other water catchment situations. The floats can activate a pump to either fill or drain based on the application.

**NORMALLY OPEN SWITCH-**  
Closes at rise = Pump Down control

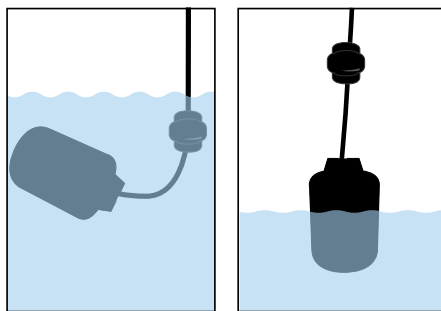

**NORMALLY CLOSED SWITCH-**  
Opens at rise = Pump Up control

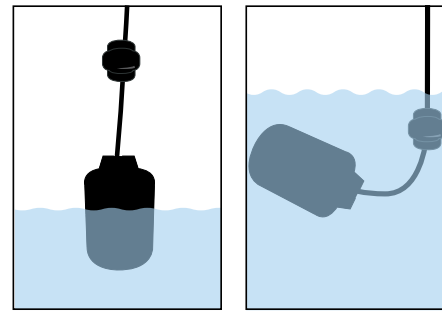

## Placement

A tether point or weight provides the pivot point for the float. Keeping the float within 9-12" of the pivot point reduces the opportunity for the float to tangle. Position the top float at the maximum fill, or the bottom float at the lowest level allows for a range of water levels to be utilized. Multiple float switches can be used to monitor varying levels, provide alarms, secondary pump, etc.

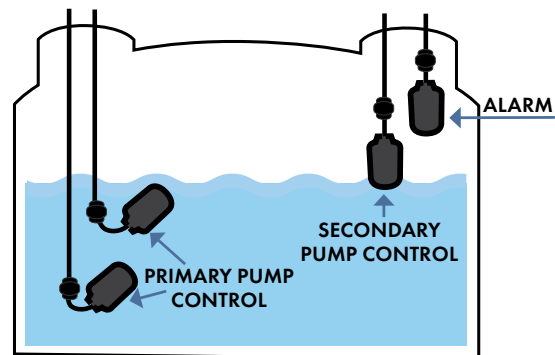
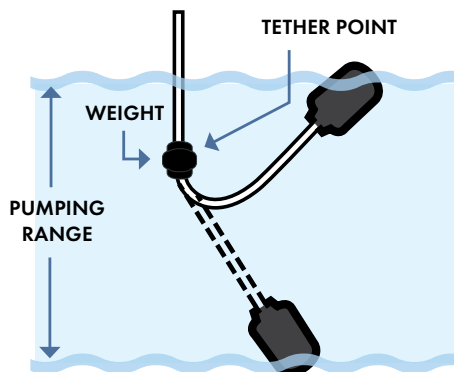

## WINTERIZATION

1. Turn off lawn controller and source water valve – break suction vacuum.
2. If feasible, disconnect water source and discharge piping. It's also a good idea to remove any intake lines and filters that are positioned in the water.
3. On pump case, open both top and bottom drain valves or plugs to remove water from pump chambers.
4. If blowing out irrigation system with pressurized air, use a narrow 9/16" box wrench (dia. 1, p.186) to prevent the shaft from spinning. When impeller spins too fast, motor governor can be damaged.
5. Once water is drained from pump case, close drain valves.
6. Fill pump case with Munro Freeze Defeat (p.188) pump winterization fluid. Munro Freeze Defeat will keep cast iron pump cases from rusting and keep the impeller free for spring start-up.

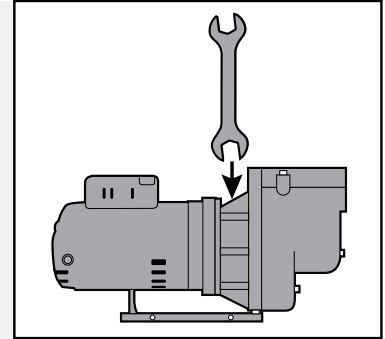

dia. 1

To see just how EASY it is to winterize your pump using Freeze Defeat!  
Visit [munropump.com/FreezeDefeat](http://munropump.com/FreezeDefeat)



## SPRING STARTUP

1. Drain the Munro Freeze Defeat.
2. Close top and bottom drain plugs or valves. Fill case with water to prime.
3. Reconnect water source and discharge piping.
4. Turn on lawn controller and source water valve.
5. If issues arise, refer to your owner's manual or the Munro Troubleshooting Guide for Centrifugal Pumps and Controls on p.235

Munro Freeze Defeat is safe for most grasses and landscaping when drained and residual diluted fluid is introduced into irrigation water. Use caution with fragile plants, flushing pump with water prior to start up.

## GOVERNING LAW & LIMITED WARRANTY FOR PUMPS, PUMP CONTROLS, VALVES, FITTINGS AND ACCESSORIES MANUFACTURED BY MUNRO

**GOVERNING LAW:** It is understood and agreed that these Terms and Conditions of Sale (this "Agreement") shall be interpreted under and pursuant to the laws of the State of Colorado; you agree that any action at law or suit which is related to any contact of sale brought against us shall be filed in a federal or state court located in the State of Colorado.

**LIMITED WARRANTY:** Munro, Inc. (the "Company") hereby warrants, in accordance with and subject to the provisions herein contained, your unit against defects in materials and workmanship under normal use and service when properly installed, following provided installation instructions for a period of 12 months or 1000 hours of operation (which ever occurs first), from the date of purchase (Continuous-duty rated products are exempt from the 1000 hours of operation stipulation). In the event of a breakdown or failure of your unit or part thereof, within the period of 12 months or 1000 hours of operation, which prevents normal function, and is found to be the result of a defect in materials or workmanship, the Company will repair the breakdown or failure and/or replace any defective part or the whole unit at the Company's discretion. Freight charges will be the customer or ultimate consumer's responsibility.

Further, we warrant to our immediate customer and to the ultimate consumer (the "Customer") that products of our manufacture will be free of defects in material and workmanship under normal use and service, when installed and maintained in accordance with our instructions, for a period of twelve (12) months from date of sale to the ultimate customer or eighteen (18) months from date of shipment to the Munro distributor, whichever occurs first. As used herein, the "Ultimate Consumer" is defined as the purchaser who first uses the product after its initial installation or, in the case of product designed for non-permanent installation, the first owner who used the product. It is our immediate customer's obligation to make known to the Ultimate Consumer the terms and conditions of this warranty. This warranty provides limited specific legal rights, and there may also be other rights, which vary from state to state. As, and to the extent, covered by the federal consumer product warranties Law (the Magnuson-Moss Act, 15 U.S. Code §2301, et seq., (1) the duration of any implied warranties associated with the product by virtue of said law is limited to the same duration as stated herein, to the fullest extent allowed, (2) this warranty is for all purposes a LIMITED WARRANTY, and (3) no claims of any nature whatsoever shall be made against the Company, unless and until the Ultimate Consumer notifies the Company in writing of the defect, and delivers the product and/or defective part(s) Customer paid freight (see Return Policy section, below) to our factory or nearest authorized service facility. Some states do not allow limitation on how long an implied warranty lasts, so the above limitation may be limited by such law, to the extent applicable. **THE SOLE AND EXCLUSIVE REMEDY FOR BREACH OF ANY AND ALL WARRANTIES WITH RESPECT TO ANY PRODUCT SHALL BE TO REPLACE OR REPAIR AT OUR ELECTION, F.O.B. POINT OF MANUFACTURER OR AUTHORIZED REPAIR FACILITY, SUCH PRODUCTS AND/OR PARTS AS PROVEN DEFECTIVE. THERE SHALL BE NO FURTHER LIABILITY, WHETHER BASED ON WARRANTY, NEGLIGENCE OR OTHERWISE.** Unless expressly stated otherwise, statements as to the nature of performance specifications furnished in addition to the foregoing material and workmanship warranties on product manufactured by the Company, if any, are subject to laboratory tests corrected for field performance. Any additional statements in the nature of performance specifications must be in writing and such writing must be signed by our authorized representative. Due to inaccuracies in field testing, if a conflict arises between the results of field testing conducted by or for user, and laboratory tests corrected for field performance, the latter shall control. Components or accessories supplied by us but manufactured by others are warranted only to the extent of, and are subject to, the terms and conditions of the original manufacturer's warranty.

**RECOMMENDATIONS FOR SPECIAL APPLICATIONS OR THOSE RESULTING FROM SYSTEMS ANALYZES AND EVALUATIONS WE CONDUCT WILL BE BASED ON OUR BEST AVAILABLE EXPERIENCE AND PUBLISHED INDUSTRY INFORMATION. SUCH RECOMMENDATIONS DO NOT CONSTITUTE A WARRANTY OF SATISFACTORY PERFORMANCE AND NO SUCH WARRANTY IS GIVEN.**

This warranty shall not apply when damage is caused by (a) improper installation, mechanical or electrical, (b) improper power (i.e., voltage, etc.) (c) lightning (d) freezing (e) sand or other abrasive material (f) scale or corrosion build-up due to excessive chemical content. This warranty does not extend to or cover the unit or any part of it which, in the opinion of the Company, has worn by wear and tear, abraded or corroded by fluid pumped or environmental conditions, run in a dry condition, operated at high temperatures or outside the technical specifications of the unit. Mechanical seal failure is not warranted outside of initial start up. Any modification of the original equipment will also void this warranty. We will not be responsible for loss, damage or labor cost due to interruption of service caused by defective parts, nor charges incurred by others without our prior written approval.

This warranty is void if our inspection reveals the product was used in a manner inconsistent with normal industry practice and/or our specific recommendations. The purchaser is responsible for communication of all necessary information regarding the intended application and use of the product.

**UNDER NO CIRCUMSTANCES WILL WE BE RESPONSIBLE FOR ANY OTHER DIRECT, INDIRECT, OR CONSEQUENTIAL DAMAGES, INCLUDING BUT NOT LIMITED TO LOST PROFITS, LOST INCOME, LABOR CHARGES, DELAYS IN PRODUCTION, IDLE PRODUCTION, REGARDLESS OF WHETHER SUCH DAMAGES ARE CAUSED BY ANY DEFECTS IN MATERIAL AND/OR WORKMANSHIP AND/OR DAMAGE OR DELAYS IN SHIPMENT. THIS WARRANTY IS EXPRESSLY IN LIEU OF ANY OTHER EXPRESS OR IMPLIED WARRANTY, INCLUDING ANY**

### WARRANTY OF MERCHANTABILITY OR FITNESS FOR A PARTICULAR PURPOSE.

No rights extended under this warranty may be assigned to any other person, whether by operation of law or otherwise, without our prior written approval. If any litigation is commenced between the parties hereto for the enforcement of any rights hereunder, the successful party in subject litigation shall be entitled to receive from the unsuccessful party all costs incurred in connection therewith, including a reasonable amount for attorney's fees.

### PRICING

All prices provided are guaranteed for only 30 days from the date of written quote, unless otherwise noted. Unless noted, prices do not include applicable taxes or freight costs. Prices are otherwise subject to change without notice. Customer is responsible for payment of all applicable state and local taxes, or for providing a valid sales tax exemption certificate. The Company reserves the right to reject any order.

### PAYMENT TERMS

The Company accepts cash, checks, money orders, direct deposit, Visa, MasterCard, Discover and American Express. Credit card payments made on the date of invoice or within 10 business days of invoice date will not incur a fee. Credit card payments made 11 or more business days after the date of invoice will incur a 3% service charge. For Customers with established credit, terms are net, due 30 days following the date of invoice. A finance charge is computed on a periodic rate of 2% per month, which is an annual rate of 24%, on any previous balance not paid within 30 days (minimum service charge of 50¢). Customer agrees to pay all costs of collection and all attorney's fees if the account becomes delinquent and is referred for collection.

### FREIGHT & SHIPPING

Freight terms are FOB the Company dock, unless otherwise noted. Unless other arrangements are made, The Company will ship to an address provided by Customer, by the most efficient means we find. Shipping and handling charges will be added to invoices. The Company is not liable for any delays in shipping or issues related to arrival times and does not guarantee delivery dates.

The Company offers free freight for US and Canadian customers on in-stock orders over \$5,000, delivered to a single location. Free freight cannot be applied to the following product categories: hose, fittings (except grooved fittings), valves (except Munro ball valves, Munro butterfly valves, and Munro foot valves), well pumps, specialty pumps, pump stations, custom products. Free freight also excludes expedited shipping, drop ships and any items that cannot be shipped via common carrier. Free freight orders will ship best method as deemed by the Company. The Company will not be responsible for any re-delivery or dock fees associated with your order.

### RETURN POLICY

- 30-days, new condition – Upon the Company's verification that the product is in new condition, the Company will provide a refund for the price paid less a 15% restocking fee, for all stock items returned in new condition within 30 days of purchase and sent freight prepaid to our factory or nearest authorized service facility. Any returned product that is damaged through misuse, is missing parts, or is in unsellable condition due to Customer tampering will result in the Customer being charged a higher restocking fee based on the condition of the product.
- Custom orders – All custom items are non-refundable. All custom order cancellations must be approved and may be denied or subject to restocking fees and other charges.
- Damaged in shipping – Great care is taken in filling, checking and packing your order. Should your order be damaged or lost in transit, write so on the delivery receipt before signing. If a truck shipment is damaged, please obtain an inspection report from the truck line immediately. The Company will help to resolve the situation to the best of our ability.
- Warranty claim – Please note that the distributor must contact the Company to initiate a Return Merchandise Authorization (RMA) before products are returned to our factory or nearest authorized service facility for warranty consideration.
- Freight – After an RMA is issued, Munro will issue a call tag to pick up the product. If the product is warrantable, the Company will cover all freight costs. If the product is deemed ineligible for warrantable, Munro will charge the distributor for the shipping both to our factory or nearest authorized service facility and, if the distributor would like the product returned, Munro will also charge for shipping back to the distributor. Munro's Packaging Guidelines must be adhered to. For complete warranty procedures and packaging guidelines, please visit: [www.munropump.com/Company-Information/Warranty-statements](http://www.munropump.com/Company-Information/Warranty-statements)

### ENTIRE AGREEMENT

No employee or agent of the Company has been authorized to make any promises, representations or warranties binding the Company, or its parent company, Munro Companies, Inc., or its owners or management, other than those contained here or those which have been reduced to writing and signed by an officer of Munro Companies, Inc. Any verbal or written statements made by an employee or agent which are contrary to the provisions of this Agreement shall be deemed mere expressions of opinion and not binding. This Agreement constitutes the entire agreement between the Company and the Customer with respect to the purchase of equipment, superseding all other agreements, whether oral or written.

**YOUR ACCEPTANCE OF ANY GOODS SUPPLIED BY US, OR ON OUR BEHALF, SHALL, WITHOUT LIMITATION CONSTITUTE ACCEPTANCE OF ALL TERMS, AND CONDITIONS STATED ABOVE.**

## GOVERNING LAW & LIMITED WARRANTY FOR PACKAGED PUMPING STATIONS

**GOVERNING LAW:** It is understood and agreed that these Terms and Conditions of Sale (this "Agreement") shall be interpreted under and pursuant to the laws of the State of Colorado; you agree that any action at law or suit which is related to any contact of sale brought against us shall be filed in a federal or state court located in the State of Colorado.

**LIMITED WARRANTY:** Munro, Inc. (the "Company") hereby warrants, in accordance with and subject to the provisions herein contained, your unit against defects in materials and workmanship under normal use and service when properly installed, following provided installation instructions for a period of 24 months or 30 months from date of sale, or 2000 hours (whichever occurs first), from the date of commissioning. In the event of a breakdown or failure of your unit or part thereof, within the period of 24 months or 2000 hours of operation, which prevents normal function, and is found to be the result of a defect in materials or workmanship, the Company will repair the breakdown or failure and/or replace any defective part or the whole unit at the Company's discretion. Freight charges will be the customer or ultimate consumer's responsibility.

If the packaged pump station is designed, by the Company, to be integrated with a Baseline, Inc., 3200 Controller and if the Baseline, Inc. components are installed in the pump station by the Company, and if the Baseline, Inc., components are in use and operating per design parameters at the time of a breakdown or failure of your unit or part thereof, the warranty period is hereby extended to 63 months from date of sale or 5000 hours (whichever occurs first), from the date of commissioning. The Company does not warrant the whole or any parts of the Baseline 3200 irrigation controller nor any Baseline components.

If the packaged pump station is originally specified and sold to be incorporated with a 100% Hunter project, and is identified as such in the Company's sale documents at the time of sale, and is commissioned as such, the warranty is hereby extended to 63 months from date of sale or 5000 hours (whichever occurs first), from the date of commissioning. The company does not warrant the whole or any part of the Hunter irrigation controller nor any Hunter irrigation components.

Further, we warrant to our immediate customer and to the ultimate consumer (the "Customer") that the products of our manufacture will be free of defects in material and workmanship under normal use and service, when installed and maintained in accordance with our instructions, for a period of twenty four (24) months from the date of commissioning or twenty-seven (27) months from the date of shipment to the Company distributor, whichever occurs first. When a packaged pump station is designed, by the Company, to be integrated with a Baseline, Inc., 3200 Controller and when the Baseline, Inc. communication components are installed in the pump station by the Company, and when the Baseline, Inc., components are in use and operating per design parameters within 60 days of commissioning and continuously throughout the warranty period, when the pump station is installed and maintained in accordance with our instructions, the warranty period is extended to a period of sixty (60) months from the date of commissioning or sixty six (66) months from the date of shipment to the Company distributor, whichever occurs first. As used herein, the "Ultimate Consumer" is defined as the purchaser who first uses the product after its initial installation or, in the case of product designed for nonpermanent installation, the first owner who used the product. It is our immediate customer's obligation to make known to the Ultimate Consumer the terms and conditions of this warranty. This warranty provides limited specific legal rights, and there may also be other rights, which vary from state to state. As, and to the extent, covered by the federal consumer product warranties law (the Magnuson-Moss Act, 15 U.S. Code §2301, et seq., (1) the duration of any implied warranties associated with the product by virtue of said law is limited to the same duration as stated herein, to the fullest extent allowed, (2) this warranty is for all purposes a LIMITED WARRANTY, and (3) no claims of any nature whatsoever shall be made against the Company, unless and until the Ultimate Consumer notifies the Company in writing of the defect, and delivers the product and/or defective part(s) Customer paid freight (see Return Policy section, below) to our factory or nearest authorized service facility. Some states do not allow limitation on how long an implied warranty lasts, so the above limitation may be limited by such law, to the extent applicable. **THE SOLE AND EXCLUSIVE REMEDY FOR BREACH OF ANY AND ALL WARRANTIES WITH RESPECT TO ANY PRODUCT SHALL BE TO REPLACE OR REPAIR AT OUR ELECTION, F.O.B. POINT OF MANUFACTURE OR AUTHORIZED REPAIR STATION, SUCH PRODUCTS AND/OR PARTS AS PROVEN DEFECTIVE. THERE SHALL BE NO FURTHER LIABILITY, WHETHER BASED ON WARRANTY, NEGLIGENCE OR OTHERWISE.** Unless expressly stated otherwise, statements as to the nature of performance specifications furnished in addition to the foregoing material and workmanship warranties on products manufactured by the Company, if any, are subject to laboratory tests corrected for field performance. Any additional statements, in the nature of performance specifications must be in writing and such writing must be signed by our authorized representative. Due to inaccuracies in field testing, if a conflict arises between the results of field testing conducted by or for user, and laboratory tests corrected for field performance, the latter shall control. Components or accessories supplied by us but manufactured by others are warranted only to the extent of and are subject to the terms and conditions of the original manufacturer's warranty.

**RECOMMENDATIONS FOR SPECIAL APPLICATIONS OR THOSE RESULTING FROM SYSTEMS ANALYSIS AND EVALUATIONS WE CONDUCT WILL BE BASED ON OUR BEST AVAILABLE EXPERIENCE AND PUBLISHED INDUSTRY INFORMATION. SUCH RECOMMENDATIONS DO NOT CONSTITUTE A WARRANTY OF SATISFACTORY PERFORMANCE AND NO SUCH WARRANTY IS GIVEN.**

This warranty shall not apply when damage is caused by (a) improper installation, mechanical or electrical, (b) improper power (i.e., voltage, etc.) (c) lightning (d) freezing (e) flooding or other acts of God (f) sand or other abrasive material (g) scale or corrosion build-up due to excessive chemical content. This warranty does not extend to or cover the unit or any part of it which, in the opinion of the Company, has worn by wear and tear, abraded or corroded by fluid pumped or environmental conditions, run in a dry condition, operated at high temperatures or outside the technical specifications of the unit. Mechanical seal failure is not warranted outside of initial start up. Any modification of the original equipment will also void this warranty. We will not be responsible for loss, damage or labor cost due to interruption of service caused by defective parts, nor charges incurred by others without our prior written approval. This warranty is void if our inspection reveals the product was used in a manner inconsistent with normal industry practice and/or our specific recommendations. The purchaser is responsible for communication of all necessary information regarding the intended application and use of the product.

**UNDER NO CIRCUMSTANCES WILL WE BE RESPONSIBLE FOR ANY OTHER DIRECT, INDIRECT, OR CONSEQUENTIAL DAMAGES, INCLUDING BUT NOT LIMITED TO LOST PROFITS, LOST INCOME, LABOR CHARGES, SERVICE OR REPAIR EQUIPMENT CHARGES, DELAYS IN PRODUCTION, IDLE PRODUCTION, REGARDLESS OF WHETHER SUCH DAMAGES ARE CAUSED BY ANY DEFECTS IN MATERIAL AND/OR WORKMANSHIP AND/OR DAMAGE OR DELAYS IN SHIPMENT. THIS WARRANTY IS EXPRESSLY IN LIEU OF ANY OTHER EXPRESS OR IMPLIED WARRANTY, INCLUDING ANY WARRANTY OF MERCHANTABILITY OR FITNESS FOR A PARTICULAR PURPOSE.**

No rights extended under this warranty shall be assigned to any other person, whether by operation of law or otherwise, without our prior written approval.

If any litigation is commenced between the parties hereto for the enforcement of any rights hereunder, the successful party in subject litigation shall be entitled to receive from the unsuccessful party all costs incurred in connection therewith, including a reasonable amount for attorney's fees.

### TERMS OF SALE

1. All pump station proposals are based on customer-supplied information. The Company does not verify site conditions, measurements, performance requirements or other variables.
2. Customer is responsible for all electrical wiring and other requirements to meet National Electrical Code (NEC) requirements.
3. Customer is responsible for all required grounding and bonding.
4. Customer is responsible for clarifying electrical supply to be utilized to power the pump station.
5. If order is placed and the electrical supply requirements on site are different than those identified in the proposal and the submittal package (all changes must be identified within these documents - no other communication will supersede these documents and any changes must be reflected in these documents), the customer will be responsible for the cost of parts, labor and U.L. listing of the control panel for changes necessary.
6. Customer is responsible for all mechanical connections not included in the proposal and/or drawings and not previously assembled by the Company.
7. Customer is responsible for signing proposal agreement and project drawings (if provided), before construction begins.
8. For custom products, expected delivery is 6-8 weeks after 1) receipt of written purchase order and subsequently 2) customer written/emailed approval of proposal and any applicable drawings (unless otherwise noted).
9. A 50% down payment is required before construction begins, and additional progress payments may also be required on larger projects, unless prior arrangements have been made. All down payments and progress payments will be presented during quoting and agreed to in writing by an authorized representative of Munro, Inc.
10. The Company will supply start up assistance. Depending on the complexity of the pump station, at the Company's discretion, customer may have the option of start-up assistance by phone (no additional cost) or start-up assistance in-person (additional cost). If on-site start up is selected or required, the Company will supply start up assistance for the time needed to commission the pump station, up to one day including travel to and from the job site (unless otherwise noted). In the event that more than one day is needed, a charge of \$150.00 per hour, shop to shop, plus mileage or other travel expenses incurred will be applied. Start up assistance indicates only work to commission the pump station. A start up authorizing document will be supplied - customer is responsible for completing and returning. A minimum of two weeks advance notice is required.
11. A printed copy of operation, installation and maintenance manuals will be supplied. A digital copy will be made available as well. Additional printed copies can be supplied at additional expense.
12. Customer is responsible for offloading pump station and related equipment at the jobsite or other specified shipping location.
13. A monthly charge of \$250.00 will be applied to all pump stations stored at the Company's Grand Junction, CO production facility longer than 30 days.

**PRICING** - All prices provided are in US dollars and are guaranteed for 30 days from the date of written quote, unless otherwise noted. Unless noted, prices do not include applicable taxes or freight costs. Prices are otherwise subject to change without notice. Customer is responsible for payment of all applicable state and local taxes, or for providing a valid sales tax exemption certificate. The Company reserves the right to reject any order.

**PAYMENT TERMS** - The Company accepts cash, checks, money orders, direct deposit, Visa, MasterCard, Discover and American Express. Credit card payments made on the date of invoice or within 10 business days of invoice date will not incur a fee. Credit card payments made 11 or more business days after the date of invoice will incur a 3% service charge. For Customers with established credit, terms are net, due 30 days following the date of invoice. A finance charge is computed on a periodic rate of 2% per month, which is an annual rate of 24%, on any previous balance not paid within 30 days (minimum service charge of 50¢). Customer agrees to pay all costs of collection and all attorney's fees if the account becomes delinquent and is referred for collection.

**FREIGHT & SHIPPING** - Freight terms are FOB the Company's dock, unless otherwise noted. Unless other arrangements are made, the Company will ship to the address provided by Customer, by the most efficient means we find. Shipping and handling charges will be added to invoices. The Company is not liable for any delays in shipping or issues related to arrival times and does not guarantee delivery dates.

### RETURN POLICY

1. 30-days, new condition - Upon the Company's verification that the product is in new condition, the Company will provide a refund for the price paid less a 15% restocking fee, for all stock items returned in new condition within 30 days of purchase and sent freight prepaid to our factory or the nearest authorized service facility. Any returned product that is damaged through misuse, is missing parts, or is in unsellable condition due to Customer tampering will result in the Customer being charged a higher restocking fee based on the condition of the product.
2. Custom orders - All custom items are non-refundable. All custom order cancellations must be approved and may be denied or subject to restocking fees and other charges.
3. Damaged in shipping - Great care is taken in filling, checking and packing your order. Should your order be damaged or lost in transit, note condition on the delivery receipt before signing. If a truck shipment is damaged, please obtain an inspection report from the truck line immediately. The Company will help to resolve the situation to the best of our ability.
4. Warranty claim - Please note that products must not be returned to our factory or the nearest authorized service facility for warranty consideration without the Company distributor first contacting the Company to initiate a Return Merchandise Authorization (RMA).
5. Freight - Freight charges to inspect the Company product will be the user's responsibility until warranty eligibility is determined. If product is warranted, the Company will cover all freight costs. The Company's Packaging Guidelines must be adhered to. Lowest cost shipping option must be used. Pre-authorization from the Company is required for expedited shipping.
6. For complete warranty procedures and packaging guidelines, please visit: [www.munropump.com/Company-Information/Warranty-statements](http://www.munropump.com/Company-Information/Warranty-statements)

**ENTIRE AGREEMENT** - No employee or agent of Munro, Inc. has been authorized to make any promises, representations or warranties binding Munro Inc., or its parent company, Munro Companies, Inc., or its owners or management, other than those contained here or those which have been reduced to writing and signed by an officer of Munro Companies, Inc. Any verbal or written statements made by an employee or agent which are contrary to the provisions of this Agreement shall be deemed mere expressions of opinion and not binding. This Agreement constitutes the entire agreement between Munro, Inc. and the Customer with respect to the purchase of equipment, superseding all other agreements, whether oral or written.

**YOUR ACCEPTANCE OF ANY GOODS SUPPLIED BY US, OR ON OUR BEHALF, SHALL, WITHOUT LIMITATION CONSTITUTE ACCEPTANCE OF ALL TERMS, AND CONDITIONS STATED ABOVE.**

## MUNRO PRODUCTS

Basket Strainers.....	183-184
Booster Pump .....	1-20
BrainBox.....	83-85
Butterfly Valve.....	169,170
Check Valve .....	176-177
Complete Pro 2.....	15-20,109-113
DamBox.....	91,92
Dewatering Pumps.....	37-39
Effluent Pumps.....	55-63
Elbows.....	138
Enclosures, Nema 3 .....	103
Flanges.....	151
Float Controls.....	100
Float Valve Kits.....	178
Foot Valve.....	171-173
Freeze Defeat.....	188
Grinder Pumps .....	23,24,62,63
Grooved Fittings .....	152-167
Hose.....	122-130
Hose Kit Assemblies.....	122-129
Specialty Pumps.....	75
Installation Guides .....	233-238
Irrigation Pumps .....	1-20
Liquid Level Control Box .....	90
Multistage Pumps .....	23,24,65-71
Multi Signal Box.....	86
Multi Pump Box.....	87
Munster .....	137
Packaged Systems .....	15-22,107-119
Pond Pumps .....	35,36
Pressure Sensor.....	102
Pressure Start Control Box .....	89
Pump Kits .....	106,124,136,185,186
LP Series Pumps.....	1-10
Pump Panels.....	93,94
Pump Stand.....	186
Pump Start Relay.....	77-79
Relay 40 & 90 Amp .....	102
RP Dewatering Series.....	26-34
Self-Priming Pump .....	1-18,104,105
Sewage Pump.....	55-63
Simplicity .....	114,115
SmartBox.....	80-82
Solids Handling Pumps .....	55-63
StandAlone.....	116,117
Start Relay, Pump.....	77-87
StartBox.....	77-79
StartBox Custom .....	95-99
Submersible Sump Pumps.....	50-54
Suction Hose Kit Assemblies.....	122-126
Temp Sensor.....	102
TimeBox.....	88
Troubleshooting Guides .....	241-256
Pump.....	241-248
StartBox .....	249
SmartBox .....	250,251
Universal Pro Enclosure .....	21,22
Utility Pumps.....	48,49
Water Feature Pumps .....	25-36
Liquid Level Control Box .....	90
Y-Strainers.....	181

## ALPHABETICAL PRODUCT LISTINGS

2" Munro Y-Strainer .....	181
2" Munro Deluxe Y-Strainer .....	181
3" Munro Y-Strainer .....	181
4" Well Pumps .....	67-71

## A

Adapters & Couplers.....	121-151
Agriculture Hose.....	130
Air and Water Hose.....	129
Air Charger.....	186
Air Hose .....	129
Air Hose Fittings.....	141
Air Operated Diaphragm Pumps.....	75
Alarm with Float Control .....	101
Aluminum Cam Fittings .....	134-138
Application	
Booster.....	191
Ground Water.....	190
Arrestors, Lightning .....	102

## B

Ball and Socket Couplers.....	140
Ball Check Valve .....	177
Ball Float Controls.....	100
Banding Tools .....	132
Basket Strainers.....	183-184
Blue Collapsible Discharge Hose .....	127
Bell Reducers.....	145
Black Rubber Discharge Hose .....	129
Black Steel Pipe Fittings.....	144-150
Bolt Clamps .....	131,132
Booster Pumps, Pressure.....	72,73
Brass Ball Valves.....	174
Brass Cam Fittings .....	134-136
Brass Check Valve.....	176
Brass Float Valve .....	178
Brass Foot Valve.....	173
Brass Gate Valve.....	174
Brass Swing Check Valve.....	176
Bushings.....	144
Butterfly Valves .....	169,170
Butterfly Valves, Munro .....	169,170

## C

Cam Adapters.....	134-136
Cam and Groove Couplings.....	134-136
Cam Couplers.....	134-136
Cam Gaskets.....	138
Cam Handles.....	138
Capacities of Steel Pipe .....	212
Caps.....	146,158
Cast Iron Foot Valve.....	173
Center Punch Tools.....	132
Centrifugal Pumps.....	1-20
Check Valves.....	176,177
Cistern Pumps.....	75
Clamping Tools.....	132
Clock.....	97
Clamps	
Double Bolt.....	132
Heavy Duty T-Bolt .....	131
Punch-Style.....	131

Spiral.....	124
Worm Gear .....	132
Collapsible Discharge Hose	
Blue.....	127
Red.....	127
Mill.....	128
Black Rubber.....	129
Complete Pro II.....	14-20,108,113
Contactors.....	102
Control Accessories.....	100-106
Control Boxes.....	76-99
Controls, Liquid level.....	90
Conversion Tables.....	213-215
Cords, Power Supply .....	105
Couplers.....	134-136,147
Crimp Sleeves.....	124
Cross.....	146
Crow Foot Couplings.....	141
Current Transformers .....	103
Custom Boxes .....	95-99
Custom Prefabricated Station .....	118,119

## D

Dam Box .....	91,92
Delay, Timer.....	101
Dewatering Pumps .....	37-49
DG Sumptrol Float Switch .....	101
Diaphragm Pumps.....	75
Discharge Check Valve.....	177
Domestic Water Pumps.....	64-73
Double Bolt Clamps .....	132
Ductile Iron Cam Fittings .....	134-136
Ductile Iron Flanged Open Gate Valve.....	174
Dust Caps & Dust Plugs.....	136

## E

Effluent Pumps.....	55-61
Elbows 45° .....	148
Elbows 45° Street .....	147
Elbows 90° .....	148
Elbows 90° Street .....	148
Electrical Outlet .....	106
Enclosures, Nema 3R.....	103

## F

FDA Food Transfer Hose.....	130
Fiber Gasket (Full Face) .....	151
Fire Hose Fittings.....	143
Fire Hose Nozzles .....	142
Fittings	
Elbows 45° .....	148
Elbows 45° Street.....	147
Elbows 90° .....	148
Elbows 90° Street.....	148
Ball and Socket.....	140
Bell Reducers .....	145
Buna Cam Gaskets .....	138
Bushings.....	144
Cam & Groove .....	134-136
Cam Handles .....	138
Caps.....	146,158

Couplers.....	136,137,141,147
Crosses.....	146
Dust Cap.....	136,158
Dust Plug.....	136
Elbows.....	138,147,148,158
Fire Hose Fittings.....	143
Flange Gaskets.....	151
Flanges.....	151
Garden Hose Fittings.....	142
Garden Hose Nozzles.....	142
Grooved Fittings, Munro.....	152-165
HDPE.....	164-165
Hose Menders.....	139
King Nipple.....	139
Mechanical Groove.....	167
Munro Munster Fitting.....	137
Pin Lug Hose Shank Couplings.....	141
Pipe Nipples.....	149,150
Plugs.....	136,147
Schedule 40 Cam Adapters.....	136
Schedule 40 Cam Couplers.....	136
Specialty Couplers.....	137
Spray Nozzles.....	142
Swadged Nipples, Munro.....	150
Tees.....	146
Universal Crow Foot Couplings.....	141
Whipchecks.....	141
Flanges	
Full Face Fiber Gasket.....	151
Full Face Rubber Gasket.....	151
One Piece Flange x Camlock.....	151
PVC.....	173
Steel Threaded.....	151
Float Control Accessories.....	179
Float Control Valves.....	179
Float Control Weights.....	100
Float Controls.....	100
Float Switches.....	100
Float Valves.....	178
Float Valve Kits.....	178
Floats.....	178
Flow Control Valve.....	179
Flow Sleeves.....	74
Food Grade Cam Fittings.....	134,135
Food Grade Suction Hose.....	130
Foot Valves	
Munro PVC Valve.....	172
Munro S.S. Irrig. Foot Valve.....	171
PVC Flanged Swing.....	173
PVC Flange.....	173
Cast Iron.....	173
Brass Foot.....	173
Frame Mounted Pumps.....	75
Freeze Defeat.....	188
Friction Loss Charts.....	205-210
Fuel Transfer Pumps.....	75
Full Lug Butterfly Valve.....	169,170
Full Port Brass Ball Valve.....	174

## G

Galvanized Pipe Fittings.....	144-150
Garden Hose Fittings.....	142
Garden Hose Nozzles.....	142
Gaskets.....	138,141,143,151,166
Gate Valves.....	174

Gauge, Dampener/Standard.....	185
Gauges, Pressure.....	185
Globe Style Silent Check Valve.....	177
Glossary.....	212-232
Associations.....	232
Pump.....	229-232
Grinder Pumps.....	23,62,63
Grooved Fittings.....	152-165

## H

HDPE.....	164-165
Hand Pump Primers.....	75
Handles.....	138
Hardware Cloth Mesh Strainer.....	182
Heavy Duty Oil Transfer Hose.....	126
High Head Self-Priming, Pump.....	1-20
H.O.A.....	96,97
Horn.....	96,97
Hose.....	121-130
Agricultural Spray.....	130
Agricultural/Septic.....	130
Air and Water.....	129
Clear Braid.....	130
Collapsible	
Black Rubber.....	129
Red.....	127
Blue.....	127
Mill.....	128
Food Grade.....	130
Oilfield.....	126
PVC Water Suction.....	122
Industrial.....	124
Reels.....	130
Rubber Water Suction.....	125
Schedule 40.....	123
Hose Adapters.....	134-137
Hose Barb Fittings.....	140
Hose Fittings.....	134-137
Hose Kit Assemblies.....	121-129
Hose Menders.....	139
Hose King Nipples.....	139
Hose Nozzles.....	142
Hose Reels.....	130
Hose Petro.....	126
Hydraulic Motor Driven Pumps.....	75

## I

Industrial Hose.....	124
Insecticide Hose.....	124
Indicator Light.....	97
Industrial Goods.....	187
Industrial Pumps	
Chemical Feed.....	75
Hot Water Circulating.....	75
Munro TP.....	75
Munro TPA.....	75
Munro TPS.....	75
Out-of-Pond.....	75
Sprayer.....	75
Irrigation Pumps.....	1-20
Irrigation Pump Operation.....	253
Irrigation Pump Wiring Connection.....	252

## K

King Hose Nipples.....	139
------------------------	-----

## L

Lawn Pumps	
LP075B.....	1-4
LP100B.....	1-4
LP150B.....	1-4
LP200B.....	1-4
LP300B.....	1-4
LP1502B.....	1,5-7
LP3005B.....	1,8-10
Self Priming High and Medium Head.....	11-13
Lightning Arrestor.....	102
Liquid Level Control.....	90
Liquid Level Switch.....	101
Low Level Control Box.....	90

## M

Measurements.....	216
Mechanical Groove Fittings.....	152-165
Mill Hose.....	128
Motor Driven Centrifugal Pumps.....	1-20
Motor Protection.....	86-93
Multi-Stage Submersible Pumps.....	65-72
Munro "Residential Sump" Series.....	51,52
Munro "Sump" Series.....	51,52
Munro 5" Multistage.....	65,66
Munro Basket Strainers.....	183,184
Munro BrainBox.....	83-85
Munro Butterfly Valve.....	169-170
Munro Controls Custom.....	95-99
Munro DamBox.....	91,92
Munro Float Valve Kit.....	178
Munro FS "A".....	23,58,59
Munro FS "A" Industrial Survivor.....	23,60,61
Munro FS "E".....	23,53,54,56,57
Munro FS "G".....	23,62,63
Munro FS "L".....	23,46,47
Munro FS "R".....	23,44,45
Munro Grooved Fittings.....	152-165
Munro Freeze Defeat.....	188
Munro Irrigation Pumps.....	1-20
Munro Multi-Signal Control Box.....	86
Munro Multi-Pump Control Box.....	87
Munro Pond Series.....	23,35,36
Munro Pressure Start Control Box.....	89
Munro Pump Control Panels.....	93,94
PVC Ball Valve.....	175
Munro PVC Butterfly Valve.....	170
PVC Check Valve.....	176,177
PVC Flange.....	173
Munro PVC Flanged Swing Foot Valve.....	167
Munro PVC Foot Valve.....	172
Munro SmartBox.....	80-82
Munro Standalone.....	116,117
Munro StartBox.....	77-79
Munro TimeBox.....	88
Munro Liquid Level Control Box.....	90

## N

Nema 3R Enclosures.....	103
Nozzles.....	142
Nyglass Cam Fittings.....	134-136

- O**
- Oilfield Suction Hose..... 126
  - Out of Pond Pumps ..... 75
- P**
- Packaged Systems ..... 15-22,107-119
  - Pin Lug Sets..... 141
  - Pipe Fittings ..... 144-150
  - Pipe Nipples ..... 149,150
  - Piston Pumps ..... 75
  - Plastic Foot Valve..... 172
  - Plugs..... 136,147
  - Plunger Pumps..... 75
  - Poly Ball Valve..... 175
  - Pond Pumps ..... 35,36
  - Power Supply Cord..... 105
  - Pressure Booster Pumps..... 1-20
  - Pressure Gauge Dampener ..... 185
  - Pressure Gauge..... 185
    - Dry Gauge - Bottom Mount..... 185
    - Liquid Filled - Bottom Mount ..... 185
  - Pressure Sensor..... 102
  - Pressure Start Box..... 89
  - Pressure Switches..... 104
  - Pressure Tanks..... 186
  - Pump
    - Centrifugal..... See Centrifugal
    - Submersible ..... See Submersible
    - Industrial..... See Industrial
  - Pump Cable..... 106
  - Pump Enclosure..... 21,22
  - Pump Panels..... 93,94
  - Pump Primers..... 75
  - Pump Savers ..... 105
  - Pump Start Relay..... 77-79,88,99
  - Punch Lock Clamps..... 131
  - PVC Air Evacuating Valve..... 179
  - PVC Ball Valve ..... 175
  - PVC Cam Couplers & Adapters ..... 136
  - PVC Check Valves..... 176
  - PVC Flanged Swing Foot Valve ..... 173
  - PVC Float Valve..... 178
  - PVC Water Suction Hose..... 122
  - PVC Industrial Hose..... 124
- Q**
- Quick Opening Knife Gate Valve..... 174
- R**
- Relief Valves..... 180
  - Roller Pumps..... 75
  - Rotary Seal Replacement ..... 254
  - Rubber Gaskets..... 151
  - Rubber Hose (Discharge)..... 129
  - Rubber Water Suction Hose..... 125
- S**
- Schedule 40 Size Hose..... 123
  - Self-Cleaning Strainer..... 184
  - Self Priming High and Medium Head-Pumps..... 11-13
  - Self Priming Pumps..... 1-20
  - Sensor, Pressure ..... 102
  - Sensor, Temperature ..... 102
  - Sewage Pumps ..... 55-63
  - Simplicity ..... 114,115
  - Sniffer Valve..... 186
  - SO Wire..... 106
  - Solids Handling Pumps ..... 55-59
  - Spiral Clamps ..... 124
  - Splice Kits..... 106
  - Spray Hose ..... 130
  - Spray Nozzles..... 142
  - Stainless Steel Ball Valve ..... 175
  - Stainless Steel Cam Fittings ..... 134-136
  - Stainless Steel Pipe Fittings ..... 144-150
  - Stand Alone..... 116,117
  - Start Relay, Pump ..... 77-87
  - Static Test Pump..... 75
  - Stems..... 179
  - Strainers..... 181-184
  - Submersible Cable ..... 106
  - Submersible Constant Pressure Systems..... 73
  - Submersible
    - Deep Well
      - Munro 5" Multistage ..... 23,65,66
      - 4" Well Pumps ..... 23,67-71
    - Dewatering
      - Munro FS "L" ..... 23,46,47
      - Munro FS "R" ..... 23,44,45
      - Munro FS Series..... 23,38-40
      - Munro Pond Series..... 23,35,36
      - Munro "Residential Dewatering"-Series ..... 23,48,49
      - Munro RP Amphibious ..... 23,28-29
      - Munro RP Large Volume..... 23,33,34
      - Munro RP Traditional..... 23,26,77
    - Effluent
      - Munro FS "E" 3/4..... 23,56,57
    - Grinder
      - Munro FS "G" ..... 23,62,63
    - Multistage
      - Munro 5" Multistage ..... 23,65,66
      - 4" Well Pumps ..... 23,67-71
    - Sewage
      - Munro FS "A" Industrial Survivor..... 23,60,61
      - Munro FS "A" ..... 23,58,59
    - Sump
      - Munro "Sump" Series ..... 23,51,52
      - Munro FS "E" 1/3 ..... 23,53,54
    - Water Feature
      - Munro Pond Series..... 23,35,36
      - Munro RP Large Volume..... 23,33,34
      - Munro RP Traditional..... 23,26,27
      - Munro RP Amphibious ..... 23,28-29
  - Submersible IPH Control Box..... 72
  - Submersible Motors..... 72
  - Submersible Pump Ends..... 68-71
  - Submersible Well Pump Flow Sleeve ..... 74
  - Submersible Well Pump Flow Sleeve and Stand 74
  - Suction Hose..... 122-126
- Suction Hose Assembly Kits ..... 122-126
- Sump & Sewage PVC Check Valve ..... 176
- Sump Pumps, Submersible..... 50-54
- Swaged Nipples ..... 150
- Switches, Float ..... 100
- Switches, Pressure..... 104
- T**
- T-Bolt Clamps..... 131
  - T-Line Strainer & Replacement Screens..... 182
  - Tank Fitting Packages..... 186
  - Tank Tees..... 186
  - Tees ..... 146
  - Temperature Sensor ..... 102
  - Threaded Flanges..... 151
  - Time Delay ..... 101
  - Trash Pumps ..... 75
  - Troubleshooting Guides..... 241-256
    - Pump..... 241-248
    - StartBox ..... 249
    - SmartBox ..... 250,251
    - Pump Operation..... 252-256
  - Turf Pumps..... 1-20
  - Two-Pole Liquid Level Switch ..... 101
- U**
- Underground Wire ..... 106
  - Universal Pump Enclosure..... 21,22
  - Unloader Valve..... 180
  - Utility Pump ..... 35,36,50-54
- V**
- Valves
- Air Evacuating
    - PVC ..... 179
  - Ball
    - Brass..... 174
    - Full Port..... 174
    - Polypropylene..... 175
    - PVC ..... 175
    - Stainless Steel ..... 175
  - Butterfly
    - Munro..... 169,170
    - PVC ..... 169
  - Check
    - Ball ..... 177
    - Brass..... 176
    - Discharge..... 177
    - Globe ..... 177
    - PVC ..... 176
    - Silent ..... 177
    - Sump and Sewage ..... 176
    - Swing..... 176
    - Wafer Style ..... 177
  - Flow Control ..... 179
  - Foot
    - Brass..... 173
    - Cast Iron..... 173
    - Flanged Swing..... 173







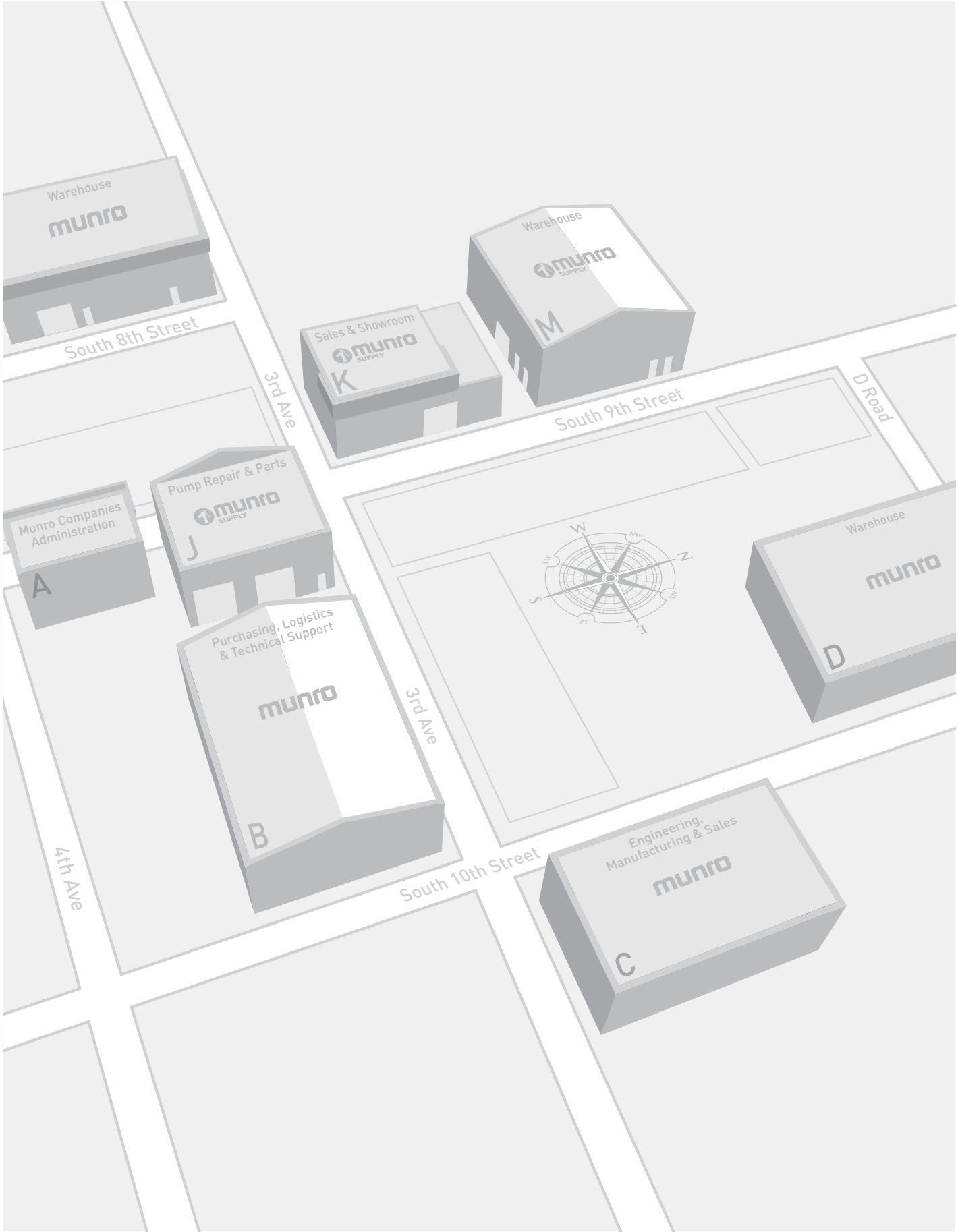

Warehouse

**munro**

South 8th Street

3rd Ave

Sales & Showroom

**munro**  
SUPPLY

K

Warehouse

**munro**  
SUPPLY

M

South 9th Street

D Road

Munro Companies  
Administration

A

Pump Repair & Parts

**munro**  
SUPPLY

J

Purchasing, Logistics  
& Technical Support

**munro**

B

3rd Ave



Warehouse

**munro**

D

4th Ave

South 10th Street

Engineering,  
Manufacturing & Sales

**munro**

C

The background features a light gray grid pattern overlaid on a field of realistic water droplets of various sizes. A large, semi-transparent white circle is centered on the page, serving as a backdrop for the contact information.

**1-800-942-4270**

[www.munropump.com](http://www.munropump.com)