

Universal Flange Adapter M7170L

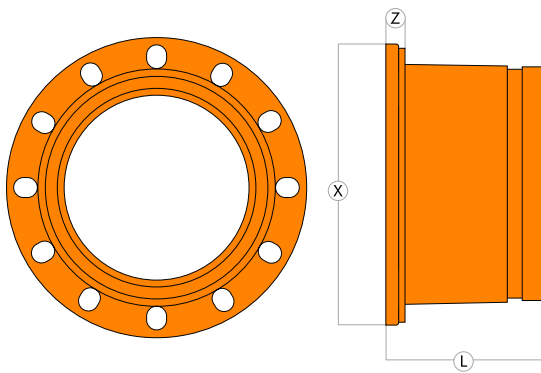

This all-in-one universal flange adapter accepts ANSI 125/150, PN10, PN16, JIS, 10K and BS-10E flange patterns. In addition, a longer grooved end makes this unique fitting easier to install.



Materials

Ductile iron, non-lead orange rust-inhibiting paint coating, ASTM A536, Grade 65-45-12

Nominal Size	Pipe OD	ANSI 125/150	PN 10/16	JIS 10K	BS 10E	Dimensions			Bolts		Approx. Weight	Model Number
						L	X	Z	Qty	Size		
in/mm	in/mm	in/mm	in/mm	in/mm	in/mm	in/mm	in/mm	in/mm		in/mm	lb/kg	
10 254	10.75 273	14.25 362	13.75 350	14.00 355	14.00 356	6.00 152	16.00 406	0.80 20.3	12	7/8 M22	40 18	M7170X10
12 300	12.75 324	17.00 432	16.15 410	15.75 400	16.00 406	6.00 152	19.00 465	1.00 25.4	12	7/8 M22	57 26	M7170X12